

Electrolux
EUROCLEAN
by Nilfisk-Advance

PARTS

S32EM465(4)99-01

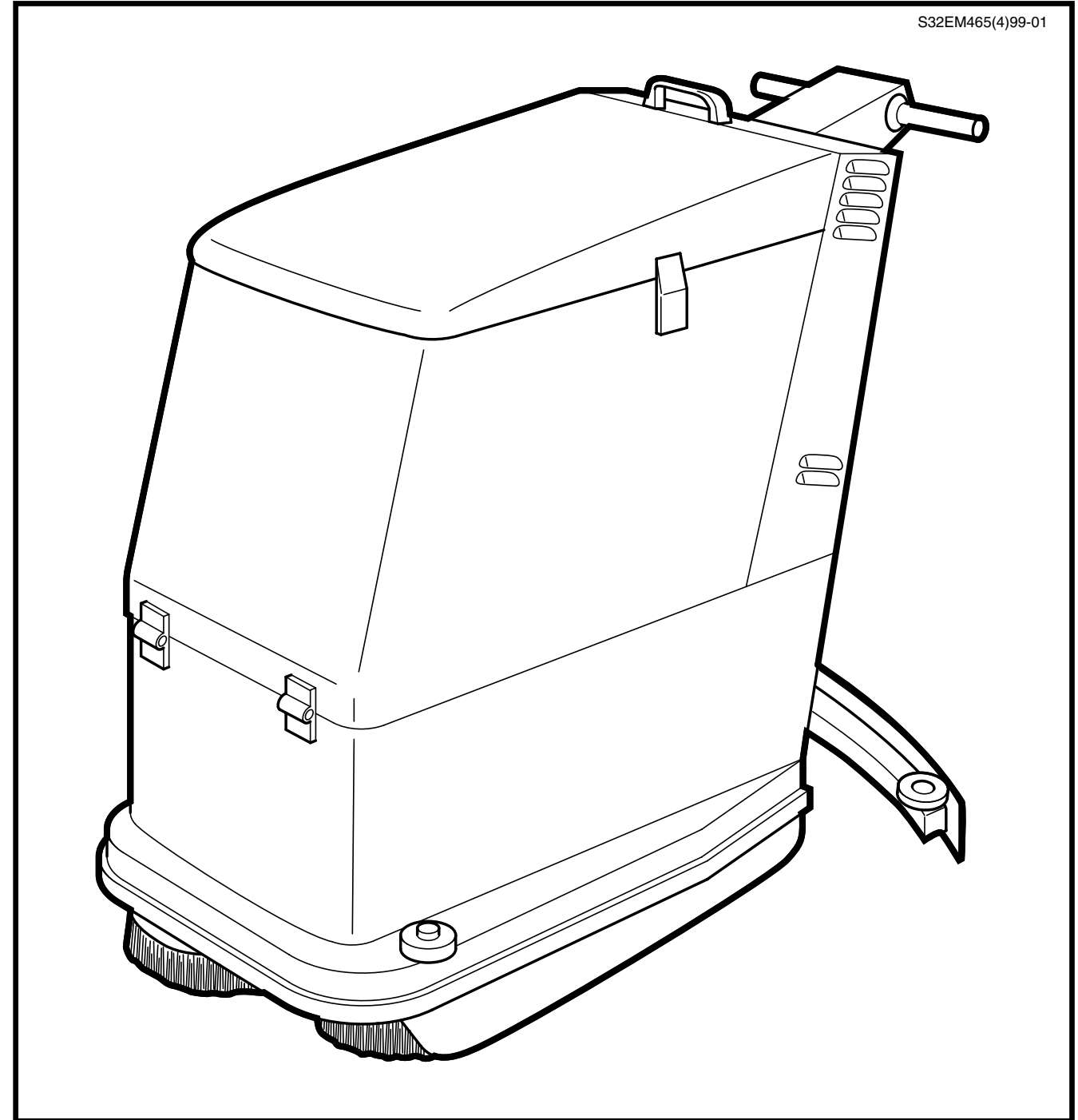

S32EM465(4)99-01

AW 465

Catalogo ricambi
Spare Parts List
Liste des pieces detachees
Ersatzteilliste

TAV. H / DRAW. H / VUE H / ZEICHN. H

AW465 S32EM465(4)99-01

POSIZ. ITEM POS. EINSAT.	CODICE CODE CODE NUMMER	CODICE INTERNO INTERNAL CODE CODE INTERIEUR INTERNE NUMMER	DESCRIZIONE DESCRIPTION DESCRIPTION BEZEICHNUNG	B	O
1	G02.13830	145 1151 000	PLANCIA / PANEL / PLANCHE / PANEEL	1	
2	G05.11130	145 0372 000	INTERRUTTORE / SWITCH / INTERRUPTEUR / SCHALTER	1	
3	G02.13760	145 0386 000	SCHEDA / CARD / PLATINE / KARTE	1	
4	G02.13820	145 1150 000	SCHEDA / CARD / PLATINE / KARTE	1	
5	L02.13700	145 0516 000	DISTANZIALE / WASHER / RONDELLE / BEILAGESCHEIBE	4	
6	G11.06400	145 8208 000	FUSIBILE / FUSE / FUSIBLE / SICHERUNG	1	
7	-	145 4918 000	PROTEZIONE / GUARD / PROTECTION / SCHUTZ	1	
8	F03.69960	145 0143 000	STAFFA / HANGER / ETRIER / BÜGEL	1	
9	H01.26150	145 0141 000	CONTENITORE / CONTAINER / BAC / BEHALTER	1	
11	G13.19480	145 0119 000	KIT CAVI BATTERIA / CABLES / CABLE / KABEL	1	
12	V03.00410	145 0507 000	VITE / SCREW / VIS / SCHRAUBE	2	
13	V09.02210	145 0246 000	RONDELLA / WASHER / RONDELLE / BEILAGESCHEIBE	2	
14	G00.04570	145 0185 000	CARICABATTERIA / BATTERY CHARGER / CHARGE ACCUMULATEUR / LADEGERÄT		1
15	V13.01910	145 9934 000	DADO / NUT / ECROU / MUTTER	2	
16	V02.00310	145 9959 000	VITE / SCREW / VIS / SCHRAUBE	2	
17	V19.00410	145 0252 000	RONDELLA / WASHER / RONDELLE / BEILAGESCHEIBE	2	
18	V09.02210	145 0246 000	RONDELLA / WASHER / RONDELLE / BEILAGESCHEIBE	2	
19	G03.01000	145 9671 000	SPINA / PIN / GOUPILLE / STIFT	1	
20	G03.01200	145 9672 000	PRESA / PLUG / PRISE / STECKER	1	
21	WOP.G0300	145 0000 000	BATTERIA 6V-240Ah / BATTERY 6V-240Ah / BATTERIE 6V-240Ah / BATTERIE 6V-240Ah		4
22	L02.16200	145 1720 000	VITE IN PLASTICA / SCREW / VIS / SCHRAUBE	4	
23	L02.16190	145 1719 000	DISTANZIALE / WASHER / RONDELLE / BEILAGESCHEIBE	4	
24	G12.01080	145 1749 000	CABLAGGIO / HARNESS / CABLAGE / KABELVERBINDUNG	1	

ACCESSORIO
OPTIONAL
ACCESSOIRES
ZUBEHÖR

VERSIONE A BATTERIA
BATTERY VERSION
VERSION A BATTERIE
BATTERIE MODELL

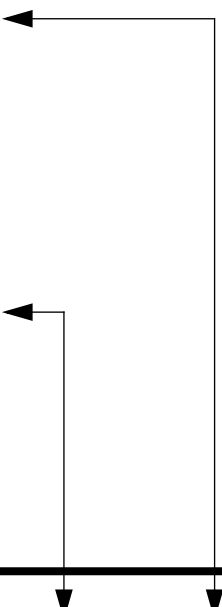

POSIZ. ITEM POS. EINSAT.	CODICE CODE CODE NUMMER	CODICE INTERNO INTERNAL CODE CODE INTERIEUR INTERNE NUMMER	DESCRIZIONE DESCRIPTION DESCRIPTION BEZEICHNUNG	B	O
12	145 0507 000	V03.00410	VITE / SCREW / VIS / SCHRAUBE	2	
13	145 0246 000	V09.02210	RONDELLA / WASHER / RONDELLE / BEILAGESCHEIBE	2	
14	145 0185 000	G00.04570	CARICABATTERIA / BATTERY CHARGER / CHARGE ACCUMULATEUR / LADEGERÄT		1
15	145 9934 000	V13.01910	DADO / NUT / ECROU / MUTTER	2	
16	145 9959 000	V02.00310	VITE / SCREW / VIS / SCHRAUBE	2	

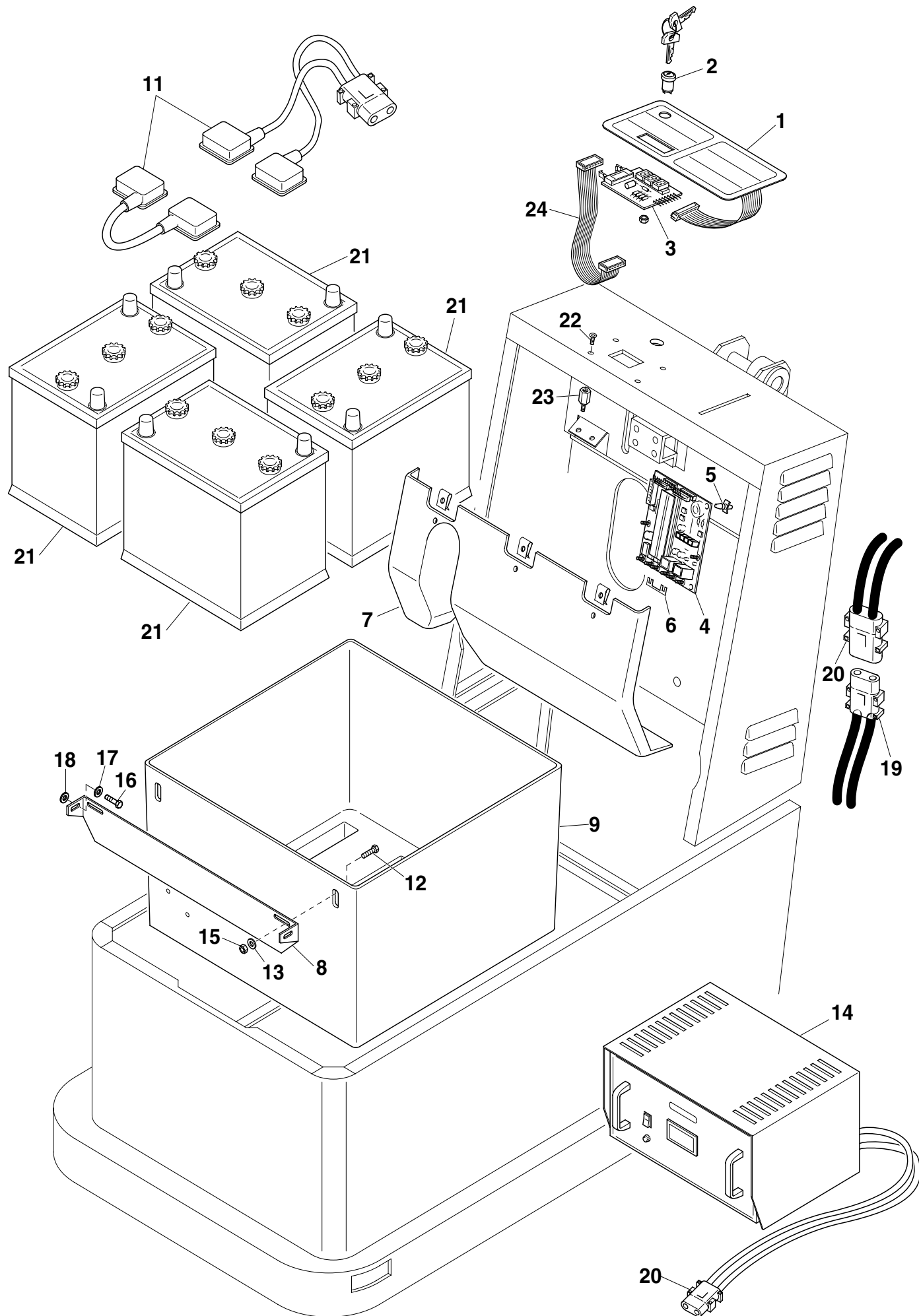

CODICE CODE CODE NUMMER	CODICE INTERNO INTERNAL CODE CODE INTERIEUR INTERNE NUMMER	ITEM DESCRIPTION	QUANTITY (for nr. 5 machines)	REF. DRAW	ITEM	CLASS	NOTE
145 1150 000	G02.13820	ELECTRONIC BOARD	1	H	4	EM	
145 1151 000	G02.13830	CONTROL PANEL	2	H	1	EM	
145 0372 000	G05.11130	KEY SWITCH	2	H	2	EM	
145 8932 000	H02.34420	REAR FLAP FOR SQUEEGEE	10	G	44	W	
145 8931 000	H02.34430	FRONT FLAP FOR SQUEEGEE	10	G	42	W	
145 8221 000	G05.04900	MICROSWITCH	3	E	7	EM	
145 1949 000	-	KNOB FOR SQUEEGEE SUPPORT	4	G	24	OM	
145 8869 000	A03.08500	WATER PUMP	2	C	16	OM	
145 9942 000	G02.12900	ELECTROVALVES WITH PLASTIC BODY	1	C	20	OM	
145 4799 000	-	MICROSWITCH	3	F	54	EM	ALSO G-40
145 4635 000	-	WHEEL (rotating-rear)	3	B	1	OM	
145 4634 000	-	WHEEL (front)	3	B	12	OM	
145 1583 000	G13.19540	POTENTIOMETER WITH CABLE (DRIVE CONTROL)	2	E	18	EM	
145 8536 000	L02.13900	LOCK FOR TANK LID	5	A	5	OM	
145 0394 000	H08.00100	FILTER FOR CLEAN WATER TANK/SUCTION	5	D	2	OM	ALSO D-19
145 5026 000	-	GASKET FOR TANK LID	5	A	3	OM	
145 0100 000	B04.03000	BRUSH STANDARD (see also other types)	10	F	40	W	
145 8208 000	G11.06400	FUSE-TAB-60 Amp	10	H	6	OM	
145 8265 000	A00.07000	VACUUM MOTOR	2	C	36	EM	
145 0411 000	H08.00060	PLASTIC FLANGE FOR VACUUM MOTOR	2	C	35	EM	
145 8497 000	R4DA0L020	KIT FOR CAP OF REAR HOSES	5	C	2	OM	
145 0386 000	G02.13760	DISPLAY ELECTRONIC BOARD	1	H	3	EM	
145 0463 000	D00.06670	WHEEL FOR SUPPORT OF THE SQUEEGEE HOLDER	2	G	46	EM	
145 0461 000	L02.16130	PLASTIC KNOB FOR ADJUSTMENT OF WHEEL D00.06670	3	G	15	EM	
145 0558 000	G05.11140	LEVEL SENSOR FOR SOLUTION TANK	3	D	1	EM	
145 8360 000	A11.00800	CARBON BRUSH (DRIVE MOTOR)	10	B	46	OM	
145 8494 000	G05.09200	LEVEL SENSOR	3	C	11	EM	
145 8645 000	A11.01100	CARBON BRUSH (brush motor)	10	F	55	OM	

CLASS: W=NORMAL WEAR PART
 OM=ORDINARY MAINTENANCE
 EM=EXTRA-ORDINARY MAINTENANCE

TAV. A / DRAW. A / VUE A / ZEICHN. A

AW465

S32EM465(4)99-01

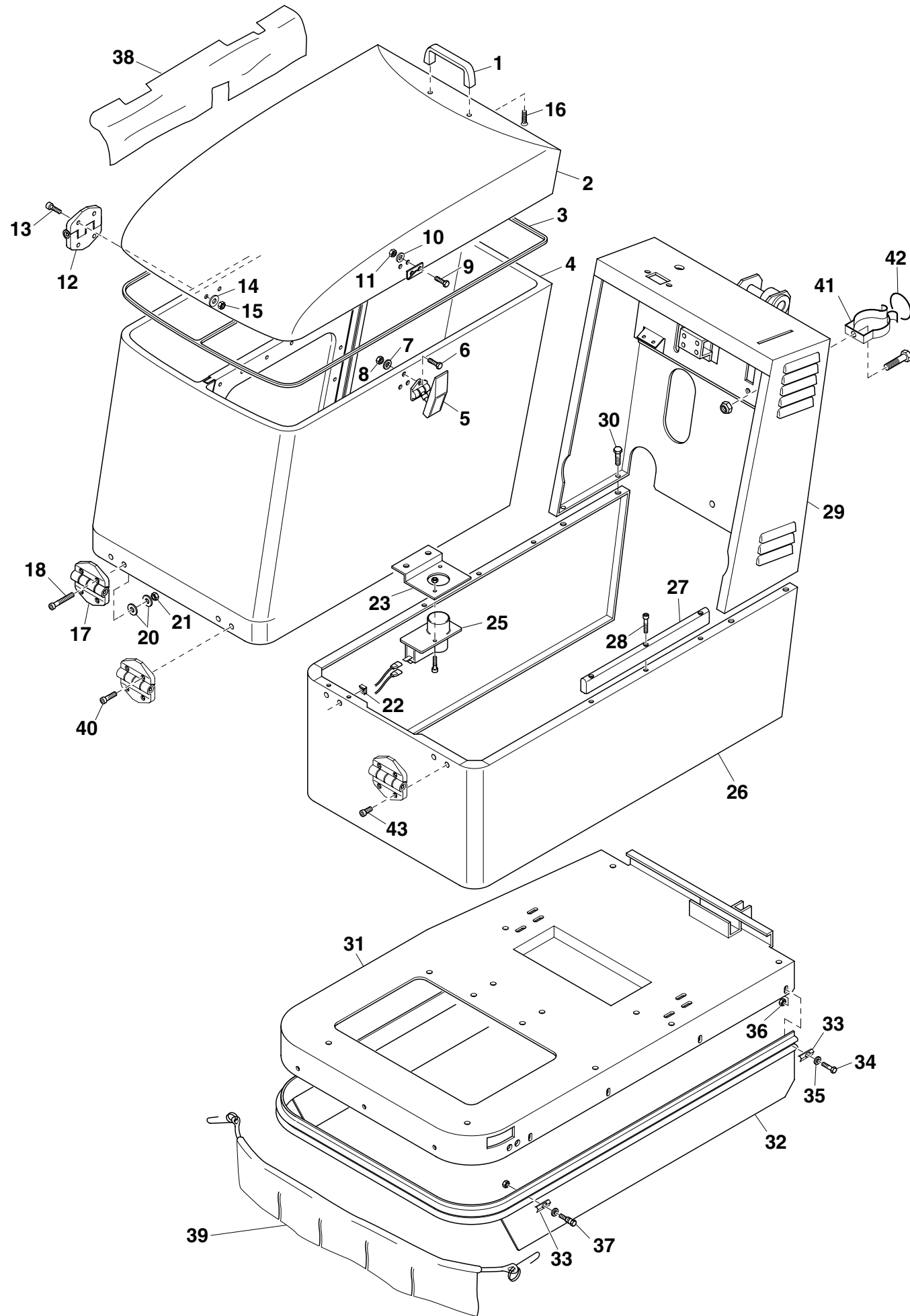

TAV. G / DRAW. G / VUE G / ZEICHN. G

AW465 S32EM465(4)99-01

POSIZ. ITEM POS. EINSAT.	CODICE CODE CODE NUMMER	CODICE INTERNO INTERNAL CODE CODE INTERIEUR INTERNE NUMMER	DESCRIZIONE DESCRIPTION DESCRIPTION BEZEICHNUNG	B	O
51	145 4962 000	-	PIASTRA / PLATE / PLAQUE / PLATTE	1	

TAV. G / DRAW. G / VUE G / ZEICHN. G

AW465

S32EM465(4)99-01

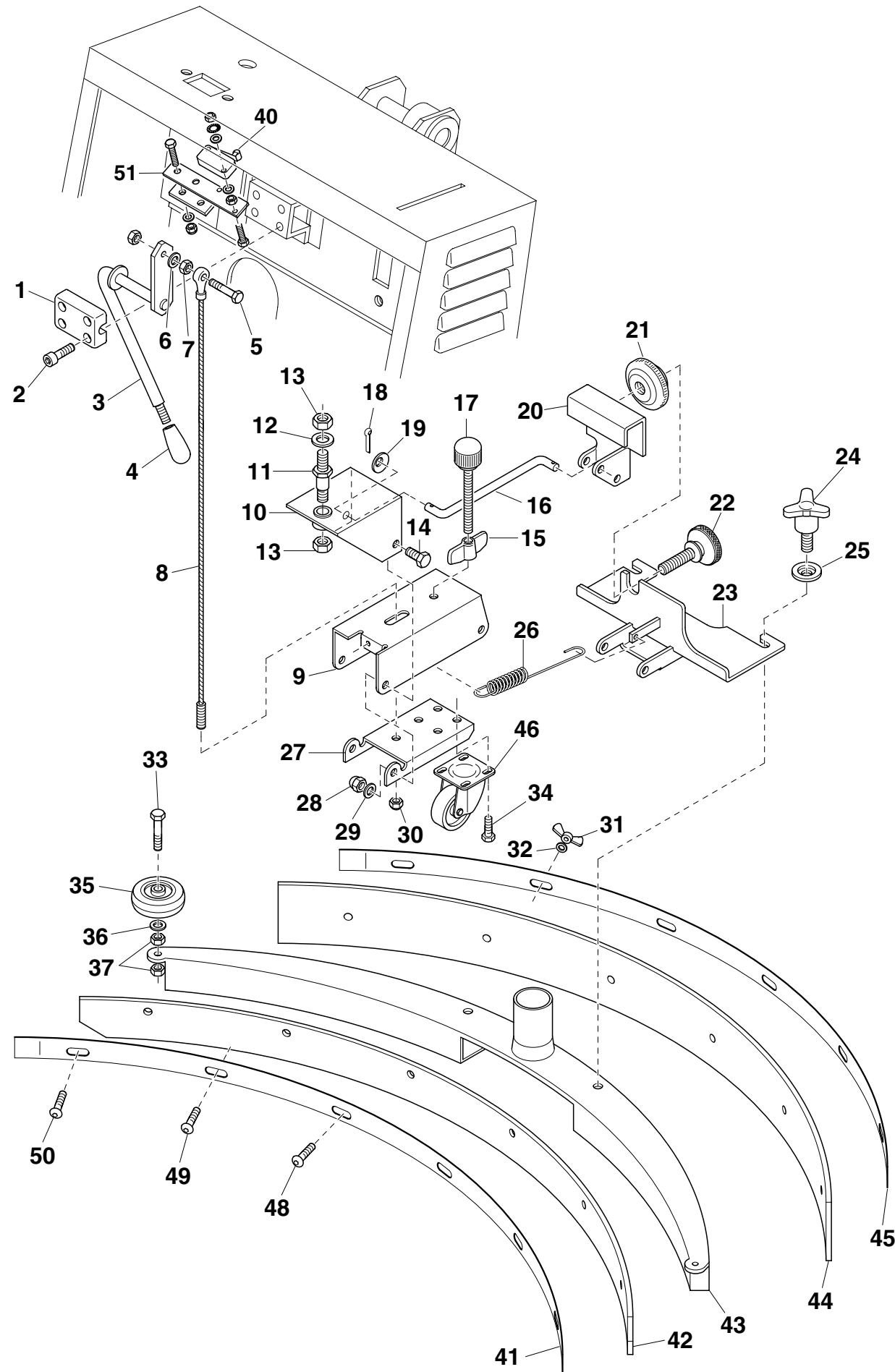

TAV. A / DRAW. A / VUE A / ZEICHN. A

AW465 S32EM465(4)99-01

POSIZ. ITEM POS. EINSAT.	CODICE CODE CODE NUMMER	CODICE INTERNO INTERNAL CODE CODE INTERIEUR INTERNE NUMMER	DESCRIZIONE DESCRIPTION DESCRIPTION BEZEICHNUNG	B	O
1	145 8461 000	L02.14000	MANIGLIA / HANDLE / POIGNEE / HANDGRIFF	1	
2	145 4930 000	-	COPERCHIO / LID COVER / COUVERCLE / DECKEL BLEU	1	
2	145 4931 000	-	COPERCHIO / LID COVER / COUVERCLE / DECKEL GREY	1	
3	145 5026 000	-	GUARNIZIONE / GASKET / JOINT / DICHTUNG	1	
4	145 4213 000	L00.05400	SERBATOIO / TANK / RESERVOIR / TANK BLU	1	
4	145 0121 000	L00.05410	SERBATOIO / TANK / RESERVOIR / TANK ROSSO	1	
4	145 0122 000	L00.05420	SERBATOIO / TANK / RESERVOIR / TANK GRIGIO	1	
5	145 8536 000	L02.13900	CHIUSURA / PROTECTION SIDE PLATE / FERMATURE / VERSCHLUSS	1	
6	145 8279 000	V02.10510	VITE / SCREW / VIS / SCHRAUBE	3	
7	145 8280 000	V09.05310	RONDELLA / WASHER / RONDELLE / BEILAGESCHEIBE	3	
8	145 8281 000	V13.01810	DADO / NUT / ECROU / MUTTERTER	3	
9	145 8279 000	V02.10510	VITE / SCREW / VIS / SCHRAUBE	2	
10	145 8280 000	V09.05310	RONDELLA / WASHER / RONDELLE / BEILAGESCHEIBE	2	
11	145 8281 000	V13.01810	DADO / NUT / ECROU / MUTTERTER	2	
12	145 0399 000	L02.16080	CERNIERA / HINGE / CHARNIERE / SCHARNIER	2	
13	145 0569 000	V04.05090	VITE / SCREW / VIS / SCHRAUBE	8	
14	145 8280 000	V09.05310	RONDELLA / WASHER / RONDELLE / BEILAGESCHEIBE	4	
15	145 8281 000	V13.01810	DADO / NUT / ECROU / MUTTERTER	4	
16	145 0568 000	V03.04410	VITE / SCREW / VIS / SCHRAUBE	2	
17	145 0399 000	L02.16080	CERNIERA / HINGE / CHARNIERE / SCHARNIER	2	
18	-	V04.01810	VITE / SCREW / VIS / SCHRAUBE	2	
20	145 8280 000	V09.05310	RONDELLA / WASHER / RONDELLE / BEILAGESCHEIBE	6	
21	145 8281 000	V13.01810	DADO / NUT / ECROU / MUTTERTER	4	
22	145 0497 000	V13.09610	DADO / NUT / ECROU / MUTTERTER	4	
23	145 4875 000	-	PIASTRA / PLATE / PLAQUE / PLATTE	1	
25	145 4820 000	-	INTERRUTTORE / SWITCH / INTERRUPTEUR / SCHALTER	1	
26	145 0315 000	F00.66330	CARENATURA / COVER / BATI / VERKLEIDUNG	1	
27	145 8273 000	F03.66400	GUIDA / SLIDE / GUIDE / FUEHRUNGSBAHN	2	
28	145 0499 000	V04.05010	VITE / SCREW / VIS / SCHRAUBE	6	
29	145 0144 000	F04.21240	SUPPORTO / SUPPORT / SUPPORT / HALTER	1	
30	145 0521 000	V02.01210	VITE / SCREW / VIS / SCHRAUBE	4	
31	145 0018 000	F01.21740	TELAIO / FRAME / CHASSIS / RAHMEN	1	
32	145 8656 000	H02.27700	PARASPRUZZI / SPLASHGUARD / BNAVETTE GUARD BOUE / SPRITZENS	1	
33	145 1180 000	H01.26340	PIASTRA / PLATE / PLAQUE / PLATTE	12	
34	145 0440 000	V02.07310	VITE / SCREW / VIS / SCHRAUBE	10	
35	145 0441 000	V09.00210	RONDELLA / WASHER / RONDELLE / BEILAGESCHEIBE	10	
36	145 0438 000	V13.06110	DADO / NUT / ECROU / MUTTERTER	15	
37	145 1108 000	V03.07103	VITE / SCREW / VIS / SCHRAUBE		2
38	145 4940 000	-	PARASPRUZZI / SPLASHGUARD / BNAVETTE GUARD BOUE / SPRITZENS	1	
39	145 0059 000	H08.00220	PARASPRUZZI / SPLASHGUARD / BNAVETTE GUARD BOUE / SPRITZENS		1
40	145 0569 000	V04.05090	VITE / SCREW / VIS / SCHRAUBE	2	
41	145 8539 000	E04.07600	FASCETTA / CLAMP / COLLIER / PASSRING	2	
42	145 0508 000	H04.09500	O-RING / O-RING / O-RING / O-RING	2	
43	145 0569 000	V04.01310	VITE / SCREW / VIS / SCHRAUBE	4	

TAV. B / DRAW. B / VUE B / ZEICHN. B

AW465

S32EM465(4)99-01

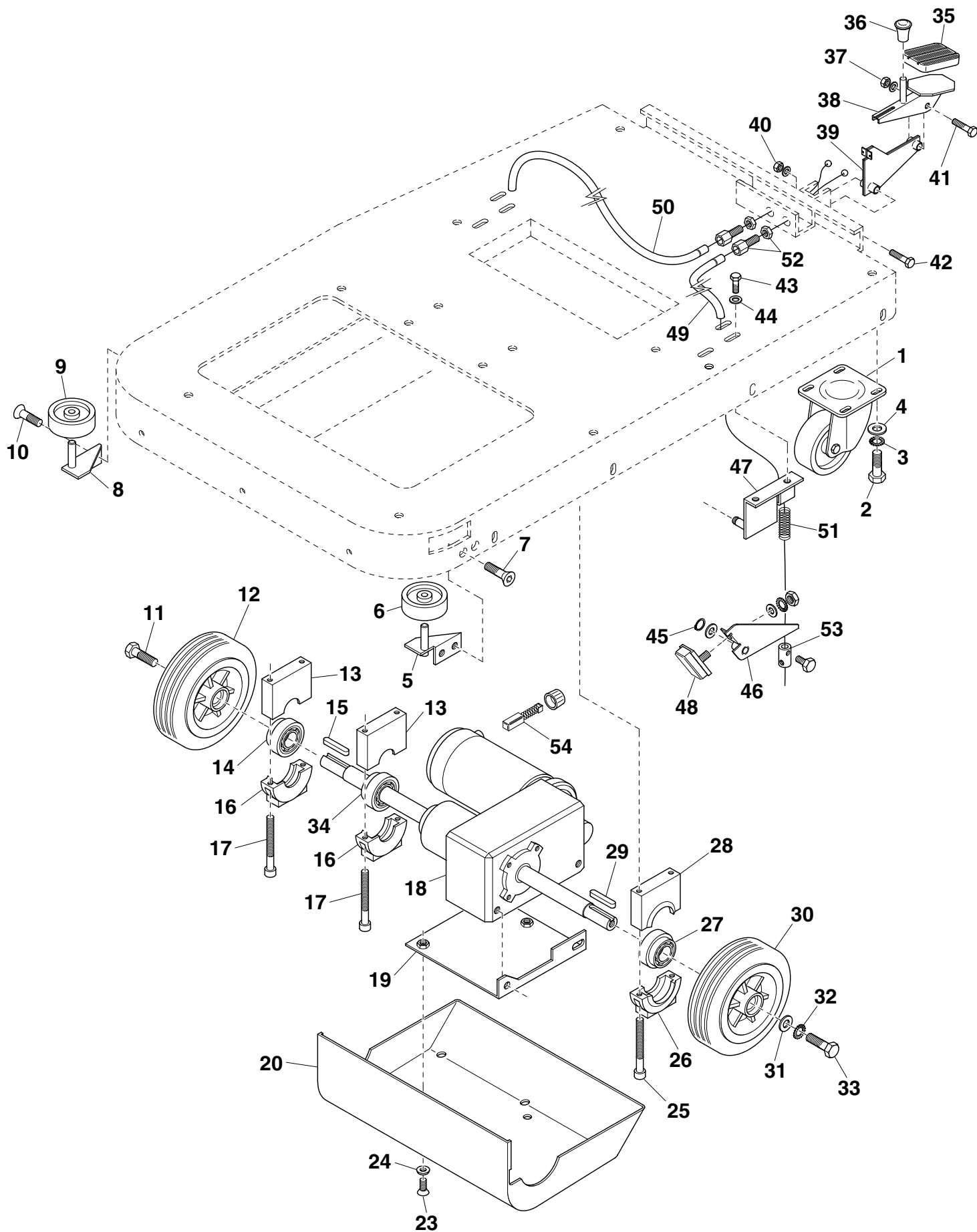

TAV. G / DRAW. G / VUE G / ZEICHN. G

AW465 S32EM465(4)99-01

POSIZ. ITEM POS. EINSAT.	CODICE CODE CODE NUMMER	CODICE INTERNO INTERNAL CODE CODE INTERIEUR INTERNE NUMMER	DESCRIZIONE DESCRIPTION DESCRIPTION BEZEICHNUNG	B	O
1	145 9954 000	L02.15800	BLOCCETTO / BLOCK / BLOC / ANPASSKOERPER	1	
2	145 0513 000	V04.01310	VITE / SCREW / VIS / SCHRAUBE	4	
3	145 9957 000	F03.66800	LEVA / LEVER / LEVIER / HEBEL	1	
4	145 9319 000	L03.02400	POMELLO / KNOB / BOULE / KUGELGRIFF	1	
5	145 0492 000	V02.00510	VITE / SCREW / VIS / SCHRAUBE	1	
6	145 9961 000	V09.00410	RONDELLA / WASHER / RONDELLE / BEILAGESCHEIBE	1	
7	145 9960 000	V13.00410	DADO / NUT / ECROU / MUTTERTER	1	
8	145 0403 000	E08.15240	CAVO / CABLE / CABLE / KABEL	1	
9	145 0449 000	F03.69890	SUPPORTO / SUPPORT / SUPPORT / HALTER	1	
10	145 0448 000	F04.21210	SNODO / LINK / JOINT / GELENK	1	
11	145 9963 000	E02.67900	VITE / SCREW / VIS / SCHRAUBE	1	
12	145 9966 000	V09.00610	RONDELLA / WASHER / RONDELLE / BEILAGESCHEIBE	2	
13	145 4518 000	V13.021	DADO / NUT / ECROU / MUTTER	2	
14	145 0458 000	V02.12940	VITE / SCREW / VIS / SCHRAUBE	1	
15	145 0461 000	L02.16130	VOLANTINO / KNOB / MOLETTE / HANDRAD	1	
16	145 0454 000	E02.69090	TIRANTE / TENSION ROD / TIRANT / ZUGSTANGE	1	
17	145 1354 000	L02.16120	POMELLO / KNOB / BOULE / KUGELGRIFF	1	
18	145 8564 000	V15.01603	COPIGLIA / SPLIT PIN / GOUPILLE / SPLINT	2	
19	145 9979 000	V09.00510	RONDELLA / WASHER / RONDELLE / BEILAGESCHEIBE	2	
20	145 0453 000	F03.69910	SUPPORTO / SUPPORT / SUPPORT / HALTER	1	
21	145 0455 000	E02.69100	RONDELLA / WASHER / RONDELLE / BEILAGESCHEIBE	1	
22	145 0456 000	L02.16110	VOLANTINO / KNOB / MOLETTE / HANDRAD	1	
23	145 0139 000	F04.21230	SUPPORTO / SUPPORT / SUPPORT / HALTER	1	
24	145 1949 000	-	VOLANTINO / KNOB / MOLETTE / HANDRAD	2	
25	145 8682 000	V14.012	SEEGER / RETAINING RING / CIRCLIPS / SICHERUNGSRINGT	2	
26	145 1115 000	E04.09570	MOLLA / SPRING / RESSORT / FEDER	1	
27	145 0039 000	F03.69940	SUPPORTO / SUPPORT / SUPPORT / HALTER	1	
28	145 0452 000	V13.06510	DADO / NUT / ECROU / MUTTER	1	
29	145 9979 000	V09.00510	RONDELLA / WASHER / RONDELLE / BEILAGESCHEIBE	8	
30	145 9934 000	V13.01910	DADO / NUT / ECROU / MUTTER	1	
31	145 1948 000	-	DADO / NUT / ECROU / MUTTER	8	
32	145 0493 000	V09.01210	RONDELLA / WASHER / RONDELLE / BEILAGESCHEIBE	8	
33	145 9980 000	V02.03110	VITE / SCREW / VIS / SCHRAUBE	2	
34	145 0464 000	V03.07370	VITE / SCREW / VIS / SCHRAUBE	4	
35	145 0384 000	D00.06650	RUOTA / WHEEL / ROUE / RAD	2	
37	145 9969 000	V13.02010	DADO / NUT / ECROU / MUTTER	2	
40	145 4799 000	-	MICROINT. / MICROSWITCH / MICROINTERRUPTEUR / MICROSCHALTER	1	
41	145 0152 000	F03.69290	PIATTINA / PLATE / PLAQUE / BAND	1	
42	145 8931 000	H02.34430	GOMMA / RUBBER / CAOUTCHOU / GUMMI	1	
43	145 1942 000	-	CORPO TERGITORE / SQUEEGEE / CORP DE SOUCEUR / SAUGFUSS	1	
44	145 8932 000	H02.34420	GOMMA POST. / RUBBER / CAOUTCHOU / GUMMI	1	
45	145 0150 000	F03.69280	PIATTINA POST. / PLATE / PLAQUE / BAND	1	
46	145 0463 000	D00.06670	RUOTA / WHEEL / ROUE / RAD	1	
48	145 0571 000	V06.00240	VITE / SCREW / VIS / SCHRAUBE	4	
49	145 0570 000	V06.00230	VITE / SCREW / VIS / SCHRAUBE	2	
50	145 0559 000	V06.00220	VITE / SCREW / VIS / SCHRAUBE	2	

TAV. G / DRAW. G / VUE G / ZEICHN. G

AW465

S32EM465(4)99-01

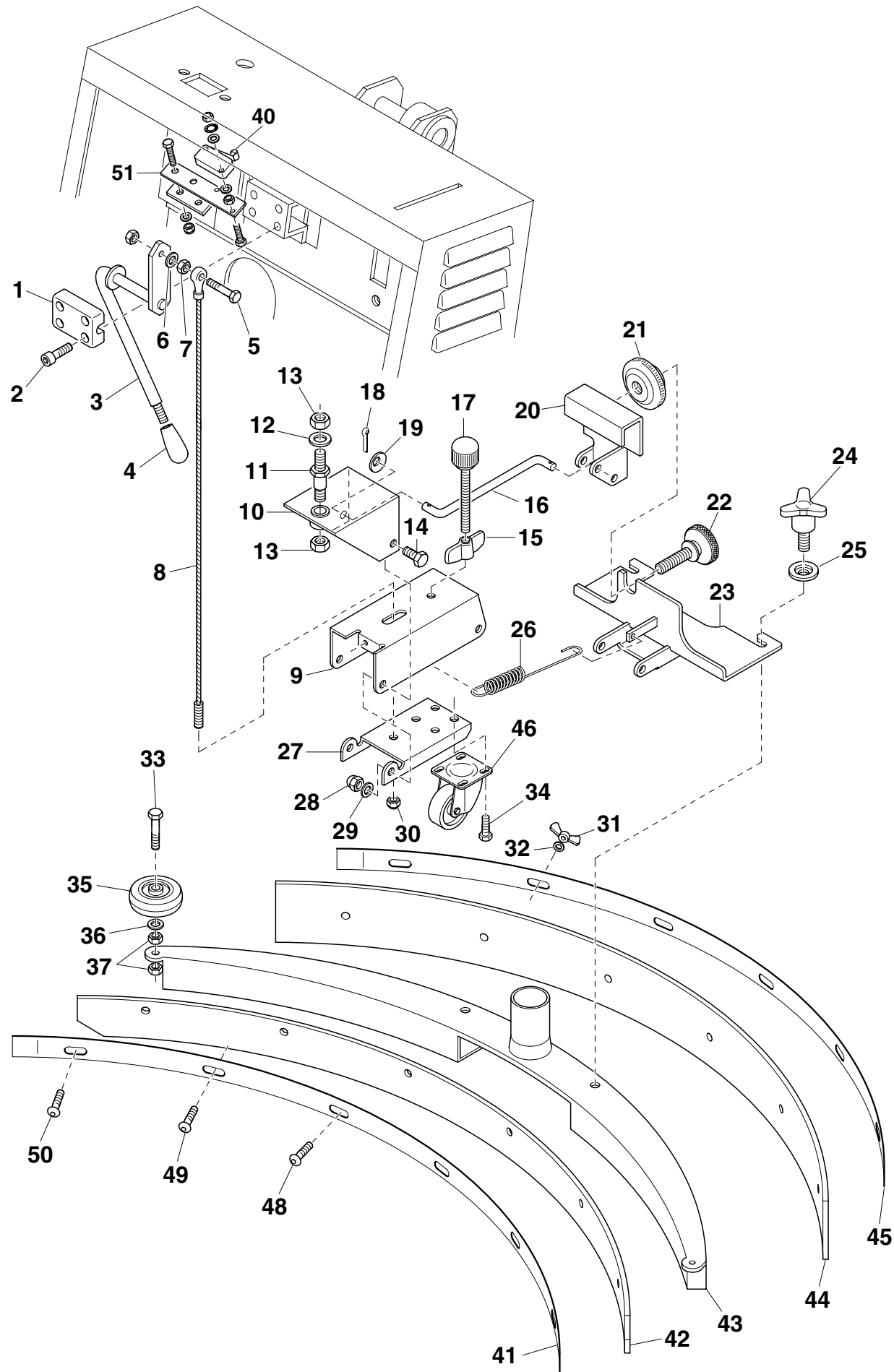

TAV. B / DRAW. B / VUE B / ZEICHN. B

AW465 S32EM465(4)99-01

POSIZ. ITEM POS. EINSAT.	CODICE CODE CODE NUMMER	CODICE INTERNO INTERNAL CODE CODE INTERIEUR INTERNE NUMMER	DESCRIZIONE DESCRIPTION DESCRIPTION BEZEICHNUNG	B	O
1	145 4635 000	-	RUOTA / WHEEL / ROUE / RAD	2	
2	145 9968 000	V02.01310	VITE / SCREW / VIS / SCHRAUBE	8	
3	145 8396 000	V19.00510	RONDELLA / WASHER / RONDELLE / BEILAGESCHEIBE	8	
4	145 8395 000	V09.02010	RONDELLA / WASHER / RONDELLE / BEILAGESCHEIBE	8	
5	145 0377 000	F04.21250	SUPPORTO / SUPPORT / SUPPORT / HALTER SX	1	
6	145 8463 000	D00.05500	RUOTA / WHEEL / ROUE / RAD	1	
7	145 0435 000	V03.00510	VITE / SCREW / VIS / SCHRAUBE	2	
8	145 0378 000	F04.21260	SUPPORTO / SUPPORT / SUPPORT / HALTER DX	1	
9	145 8463 000	D00.05500	RUOTA / WHEEL / ROUE / RAD	1	
10	145 0435 000	V03.00510	VITE / SCREW / VIS / SCHRAUBE	2	
11	145 1120 000	V02.12950	VITE / SCREW / VIS / SCHRAUBE	1	
12	145 4634 000	-	RUOTA / WHEEL / ROUE / RAD	1	
13	145 1976 000	-	SUPPORTO / WHEEL / SUPPORT / HALTER	2	
14	145 1123 000	E00.07640	CUSCINETTO / BALL BEARING / ROULEMENT / LAGER	1	
15	145 8457 000	V17.10200	LINGUETTA / TAB / CLAVETTE / KEIL	1	
16	145 1977 000	-	SUPPORTO / WHEEL / SUPPORT / HALTER	2	
17	145 1126 000	V04.05070	VITE / SCREW / VIS / SCHRAUBE	4	
18	145 8662 000	A00.06700	MOTODIFFERENZIALE / MOTOR / MOTEUR / MOTOR	1	
19	145 1127 000	F03.65300	STAFFA / HANGER / ETRIER / BÜGEL	1	
20	145 0027 000	H01.26160	CARTER / CRANKCASE / CARTER / GEHÄUSE	1	
21	145 1117 000	F04.21030	SUPPORTO / SUPPORT / SUPPORT / HALTER	2	
22	145 1116 000	F04.21040	SUPPORTO / SUPPORT / SUPPORT / HALTER	2	
23	145 0435 000	V03.00310	VITE / SCREW / VIS / SCHRAUBE	2	
24	145 1129 000	V11.02330	RONDELLA / WASHER / RONDELLE / BEILAGESCHEIBE	2	
25	145 1126 000	V04.05070	VITE / SCREW / VIS / SCHRAUBE	4	
26	145 1977 000	-	SUPPORTO / WHEEL / SUPPORT / HALTER	2	
27	145 1123 000	E00.07640	CUSCINETTO / BALL BEARING / ROULEMENT / LAGER	1	
28	145 1976 000	-	SUPPORTO / WHEEL / SUPPORT / HALTER	2	
29	145 8457 000	V17.10200	LINGUETTA / TAB / CLAVETTE / KEIL	1	
30	145 8258 000	D00.06500	RUOTA / WHEEL / ROUE / RAD	1	
31	145 0494 000	V09.02510	RONDELLA / WASHER / RONDELLE / BEILAGESCHEIBE	1	
32	145 9979 000	V09.00510	RONDELLA / WASHER / RONDELLE / BEILAGESCHEIBE	1	
33	145 1120 000	V02.12950	VITE / SCREW / VIS / SCHRAUBE	1	
34	145 1123 000	E00.07640	CUSCINETTO / BALL BEARING / ROULEMENT / LAGER	2	
35	145 8478 000	H02.063	COPRIPEDALE / PEDAL COVER / HOUSSE PEDALE / PEDALDECKUNG	1	
36	145 1134 000	H08.00080	GOMMA / RUBBER / CAOUTCHOU / GUMMI	1	
37	145 0452 000	V13.06510	DADO / NUT / ECROU / MUTTER	1	
38	145 1133 000	F04.21020	PEDALE / PEDAL / PEDALE / PEDAL	1	
39	145 1132 000	F04.21010	LEVA / LEVER / LEVIER / HEBEL	1	
40	145 9969 000	V13.02010	DADO / NUT / ECROU / MUTTER	1	
41	145 0478 000	V02.01410	VITE / SCREW / VIS / SCHRAUBE	1	
42	145 0509 000	V02.01510	VITE / SCREW / VIS / SCHRAUBE	1	
43	145 9959 000	V02.00310	VITE / SCREW / VIS / SCHRAUBE	4	
44	145 9961 000	V09.00410	RONDELLA / WASHER / RONDELLE / BEILAGESCHEIBE	4	
45	145 8682 000	V14.012	SEEGER / RETAINING RING / CIRCLIPS / SICHERUNGSRINGT	2	
46	145 1117 000	F04.21030	SUPPORTO / WHEEL / SUPPORT / HALTER	2	

TAV. B / DRAW. B / VUE B / ZEICHN. B

AW465

S32EM465(4)99-01

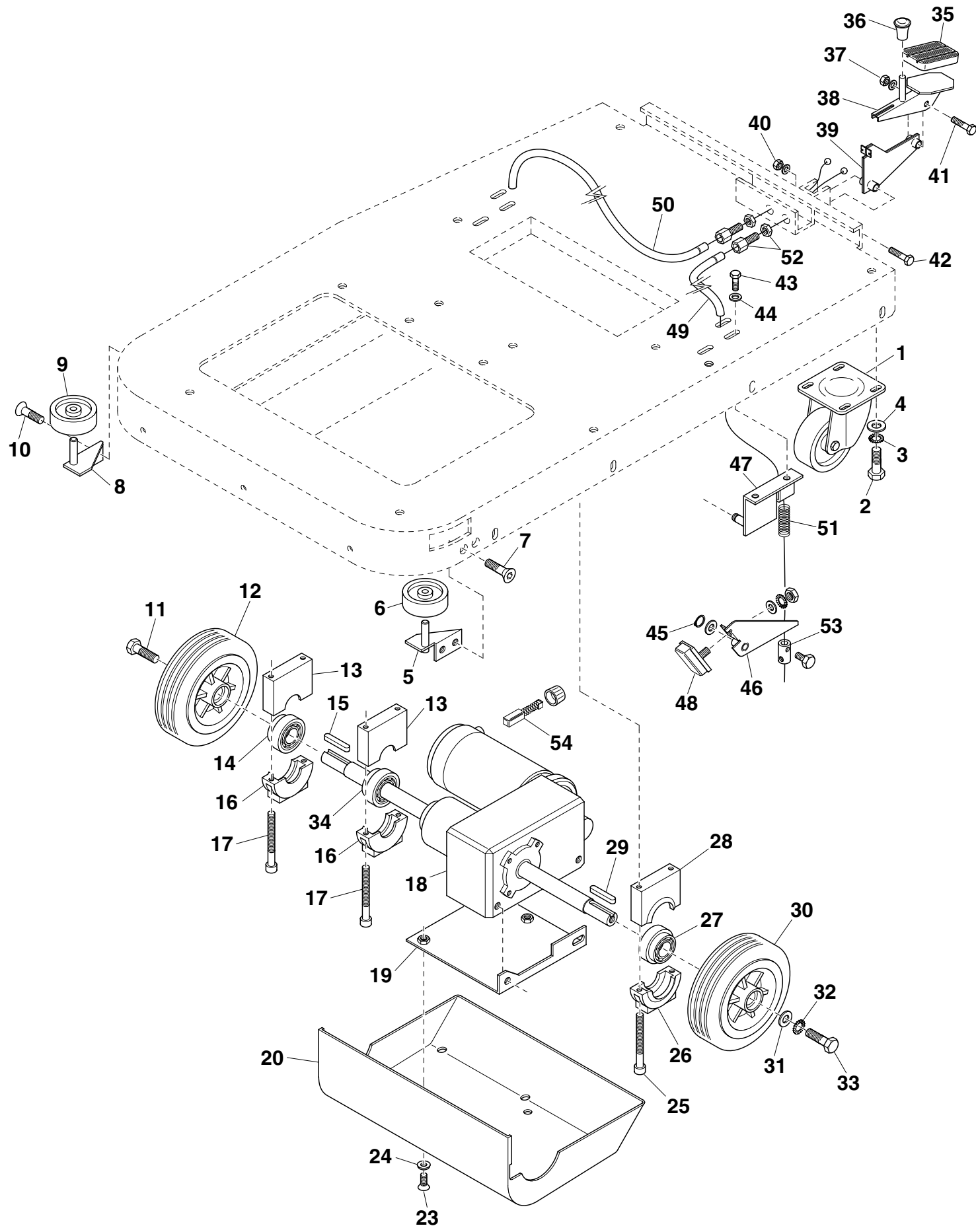

TAV. F / DRAW. F / VUE F / ZEICHN. F

AW465 S32EM465(4)99-01

POSIZ. ITEM POS. EINSAT.	CODICE CODE CODE NUMMER	CODICE INTERNO INTERNAL CODE CODE INTERIEUR INTERNE NUMMER	DESCRIZIONE DESCRIPTION DESCRIPTION BEZEICHNUNG	B	O
40	145 0104 000	B04.04000	DISCO TRASCINAT. / PAD HOLDER / DISQUE D'ENTRAIN / TREIBTELLER		2
41	145 0493 000	V09.01210	RONDELLA / WASHER / RONDELLE / BEILAGESCHEIBE	2	
42	145 0492 000	V02.00510	VITE / SCREW / VIS / SCHRAUBE	2	
43	145 8655 000	F04.17100	GUIDA / SLIDE / GUIDE / FUEHRUNGSBAHN	1	
44	145 8653 000	H02.27900	FLAP / FLAP / FLAP / FLAP	1	
45	145 8664 000	F03.57100	PIATTINA / PLATE / PLAQUE / BAND	1	
46	145 9961 000	V09.00410	RONDELLA / WASHER / RONDELLE / BEILAGESCHEIBE	7	
47	145 9936 000	V03.00310	VITE / SCREW / VIS / SCHRAUBE	7	
48	145 1732 000	RDDBORE27	MOZZO / HUB / MOYEU / NABE SX	1	
49	145 4093 000	H02.34400	FLAP / FLAP / FLAP / FLAP	1	
50	145 3562 000	F03.69210	PIATTINA / PLATE / PLAQUE / BAND	1	
51	145 4094 000	H02.34410	FLAP / FLAP / FLAP / FLAP	1	
52	145 3563 000	F03.69220	PIATTINA / PLATE / PLAQUE / BAND	1	
53	145 4926 000	-	MONTANTE / SUPPORT / SUPPORT / PFOSTEN	1	
54	145 4799 000	-	MICROINT. / MICROSWITCH / MICROINTERRUPTEUR / MICROSCHALTER	1	
55	145 8645 000	A11.01100	CARBONCINO / CARBON BRUSH / FUSAIN / KOHLENSTIFT	2	

TAV. F / DRAW. F / VUE F / ZEICHN. F

AW465

S32EM465(4)99-01

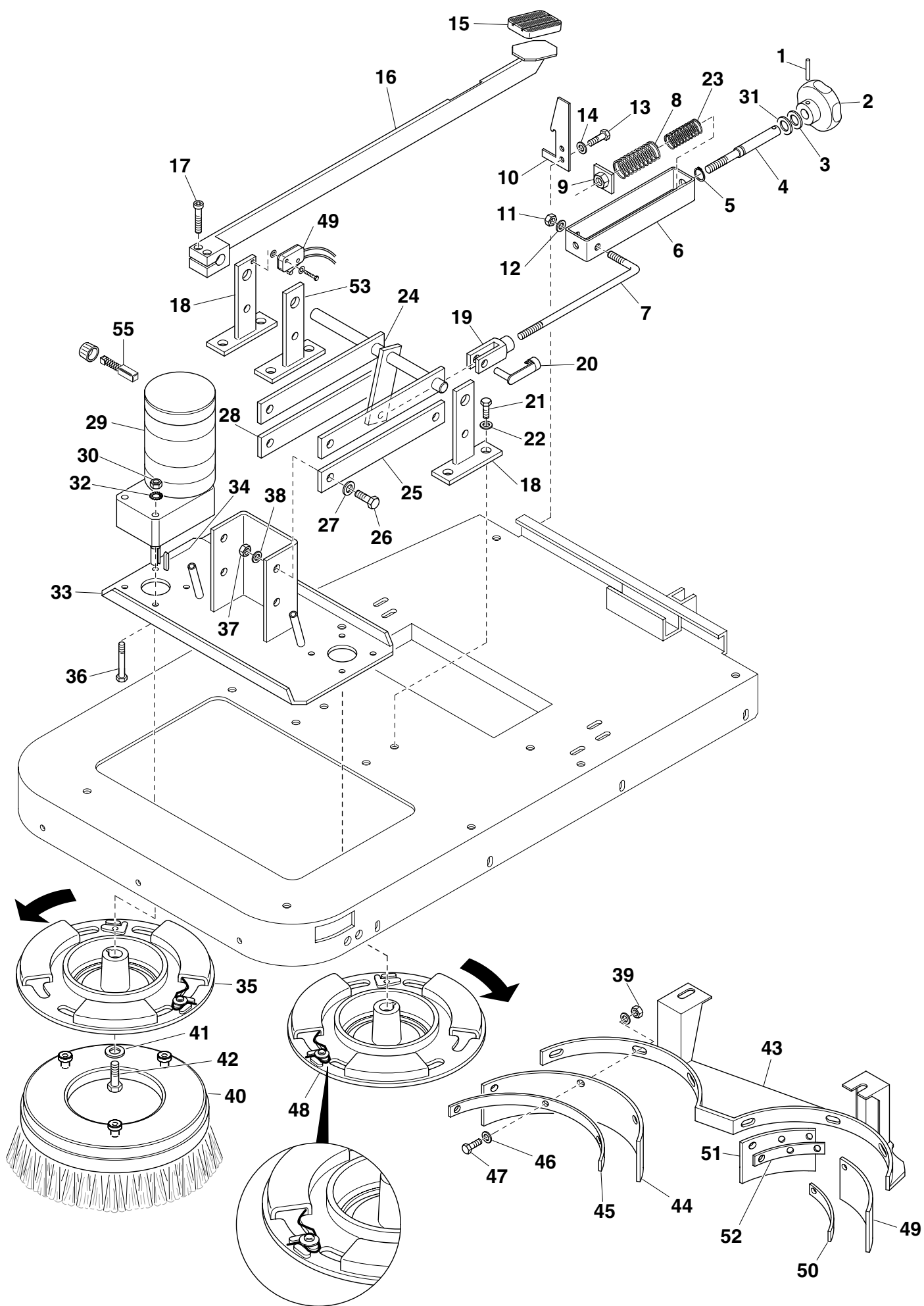

TAV. B / DRAW. B / VUE B / ZEICHN. B

AW465 S32EM465(4)99-01

POSIZ. ITEM POS. EINSAT.	CODICE CODE CODE NUMMER	CODICE INTERNO INTERNAL CODE CODE INTERIEUR INTERNE NUMMER	DESCRIZIONE DESCRIPTION DESCRIPTION BEZEICHNUNG	B	O
47	145 1116 000	F04.21040	SUPPORTO / SUPPORT / SUPPORT / HALTER	2	
48	145 1131 000	L04.02600	COPPIA PATTINI / BRAKE / FREIN / BREMSE	1	
49	-	E08.15260	CAVO / CABLE / CABLE / KABEL SX	1	
50	-	E08.15250	CAVO / CABLE / CABLE / KABEL DX	1	
51	-	E04.015	MOLLA / SPRING / RESSORT / FEDER	2	
52	145 1179 000	E08.06800	REGISTRO / REGISTER / REGISTER / REGISTER	2	
53	145 1137 000	E08.15180	FERMACAVO / RETAINER / INACTIF / UNBEWEGLICH	2	
54	145 8618 000	A11.02000	CARBONCINO / CARBON BRUSH / FUSAIN / KOHLENSTIFT	2	

TAV. C / DRAW. C / VUE C / ZEICHN. C

AW465

S32EM465(4)99-01

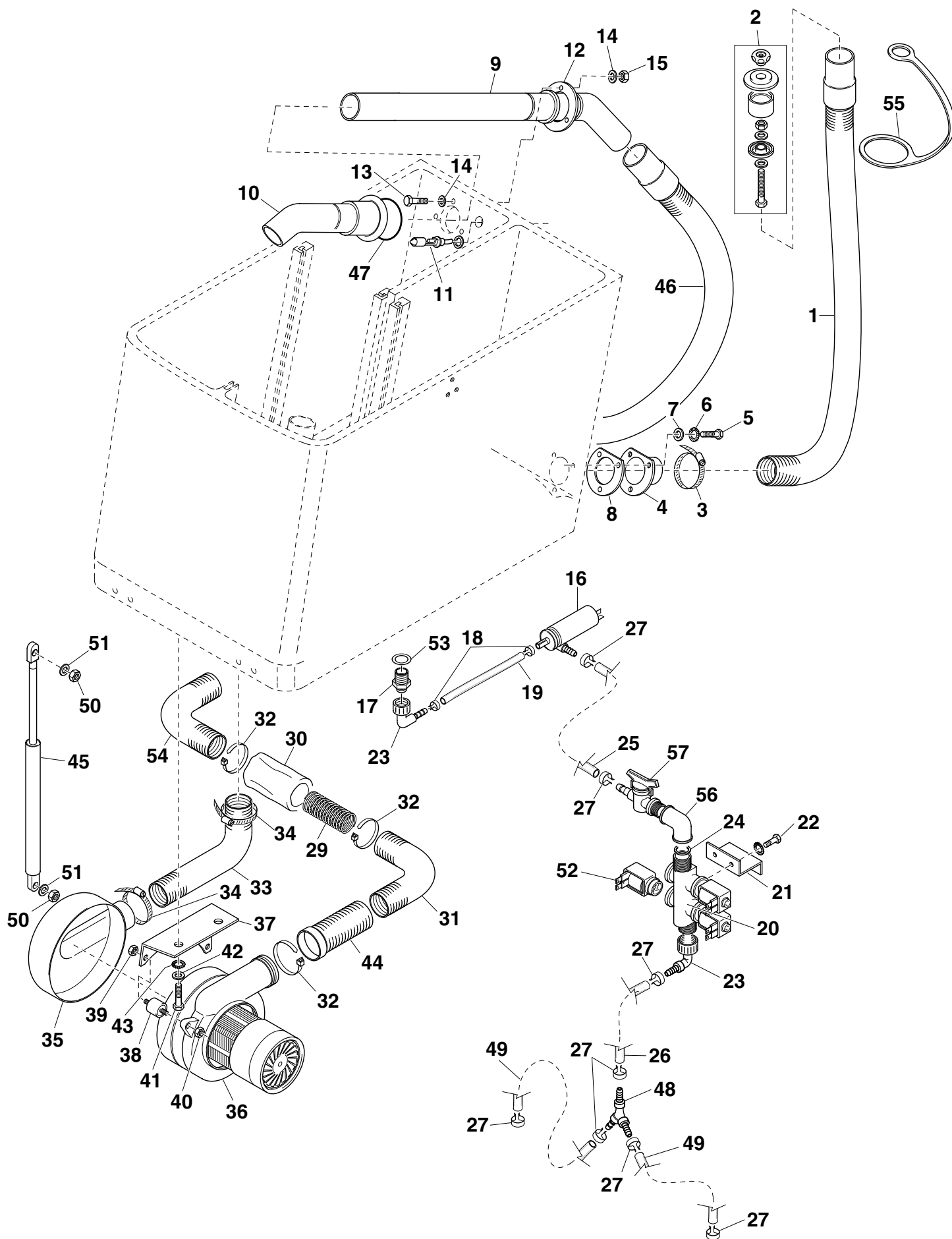

TAV. F / DRAW. F / VUE F / ZEICHN. F

AW465 S32EM465(4)99-01

POSIZ. ITEM POS. EINSAT.	CODICE CODE CODE NUMMER	CODICE INTERNO INTERNAL CODE CODE INTERIEUR INTERNE NUMMER	DESCRIZIONE DESCRIPTION DESCRIPTION BEZEICHNUNG	B	O
1	145 0487 000	V17.11200	SPINA / PIN / GOUPILLE / STIFT	1	
2	145 0486 000	LO2.16150	VOLANTINO / KNOB / MOLETTE / HANDRAD	1	
3	145 0488 000	V09.00750	RONDELLA / WASHER / RONDELLE / BEILAGESCHEIBE	1	
4	145 0485 000	E02.67400	ALBERO / SHAFT / ARBRE / WELLE	1	
5	145 9187 000	V14.006	SEEGER / RETAINING RING / CIRCLIPS / SICHERUNGSRINGT	1	
6	145 0482 000	F03.45000	CONTENITORE / CONTAINER / BAC / BEHALTER	1	
7	145 1148 000	E02.68200	TIRANTE / TENSION ROD / TIRANT / ZUGSTANGE	1	
8	145 0484 000	E04.09430	MOLLA / SPRING / RESSORT / FEDER	1	
9	145 0483 000	F04.12500	DADO ANTIROTAZIONE / NUT / ECROU / MUTTER	1	
10	145 0505 000	F03.69490	PIASTRA / PLATE / PLAQUE / PLATTE	1	
11	145 9978 000	V13.00510	DADO / NUT / ECROU / MUTTER	1	
12	145 8396 000	V19.00510	RONDELLA / WASHER / RONDELLE / BEILAGESCHEIBE	1	
13	145 9959 000	V02.00310	VITE / SCREW / VIS / SCHRAUBE	2	
14	145 0252 000	V19.00410	RONDELLA / WASHER / RONDELLE / BEILAGESCHEIBE	2	
15	145 8478 000	H02.063	COPRIPEDALE / PEDAL COVER / HOUSSE PEDALE / PEDALDECKUNG	1	
16	145 3669 000	F04.20920	PEDALE / PEDAL / PEDALE / PEDAL	1	
17	145 9828 000	V01.01900	VITE / SCREW / VIS / SCHRAUBE	2	
18	145 3671 000	F04.20940	MONTANTE / SUPPORT / SUPPORT / PFOSTEN	2	
19	145 8472 000	V17.022	FORCELLA / FORK / FOURCHETTE / GABELSTUECK	1	
20	145 8473 000	V17.023	CLIP / CIRCLIP / CLIP / KLIPP	1	
21	145 9968 000	V02.01310	VITE / SCREW / VIS / SCHRAUBE	6	
22	145 8395 000	V09.02010	RONDELLA / WASHER / RONDELLE / BEILAGESCHEIBE	6	
23	145 2645 000	F04.09440	MOLLA / SPRING / RESSORT / FEDER	1	
24	145 3668 000	F04.20910	LEVA / LEVER / LEVIER / HEBEL	1	
25	145 3670 000	F04.20930	LEVA / LEVER / LEVIER / HEBEL	1	
26	145 0478 000	V02.01410	VITE / SCREW / VIS / SCHRAUBE	6	
27	145 0477 000	E05.18500	DISTANZIALE / WASHER / RONDELLE / BEILAGESCHEIBE	6	
28	145 3670 000	F04.20930	LEVA / LEVER / LEVIER / HEBEL	1	
29	145 0471 000	A05.01750	MOTORID. / REDUCTION GEAR / MOTORED. / VERMINDERUNGSGETRIEBE	2	
30	145 9934 000	V13.01910	DADO / NUT / ECROU / MUTTER	8	
31	145 9165 000	V09.007	RONDELLA / WASHER / RONDELLE / BEILAGESCHEIBE	1	
32	145 0470 000	V22.00110	RONDELLA / WASHER / RONDELLE / BEILAGESCHEIBE	8	
33	145 3650 000	F04.16800	PIASTRA / PLATE / PLAQUE / PLATTE	1	
34	145 8470 000	V17.10100	CHIAVETTA / KEY / CLAVETTE / KEILNUT	2	
35	145 4379 000	RDDBORE26	MOZZO / HUB / MOYEU / NABE DX	1	
36	145 1143 000	V04.00210	VITE / SCREW / VIS / SCHRAUBE	8	
37	145 9969 000	V13.02010	DADO / NUT / ECROU / MUTTER	6	
38	145 8395 000	V09.02010	RONDELLA / WASHER / RONDELLE / BEILAGESCHEIBE	6	
39	145 9934 000	V13.01910	DADO / NUT / ECROU / MUTTER	7	
40	145 0100 000	B04.03000	SPAZZOLA / BRUSH / BROSSSE / BUERSTE STANDARD		2
40	145 0101 000	B04.03100	SPAZZOLA / BRUSH / BROSSSE / BUERSTE SOFT		2
40	145 0102 000	B04.03200	SPAZZOLA / BRUSH / BROSSSE / BUERSTE IN SAGGINA		2
40	145 0103 000	B04.03300	SPAZZOLA / BRUSH / BROSSSE / BUERSTE IN TYNEX		2
40	145 2313 000	B04.04800	DISCO / PAD / DISQUE / DISK NERO		2
40	145 2317 000	B04.05200	DISCO / PAD / DISQUE / DISK ROSSO		2
40	145 2318 000	B04.05300	DISCO / PAD / DISQUE / DISK VERDE		2

TAV. F / DRAW. F / VUE F / ZEICHN. F

AW465

S32EM465(4)99-01

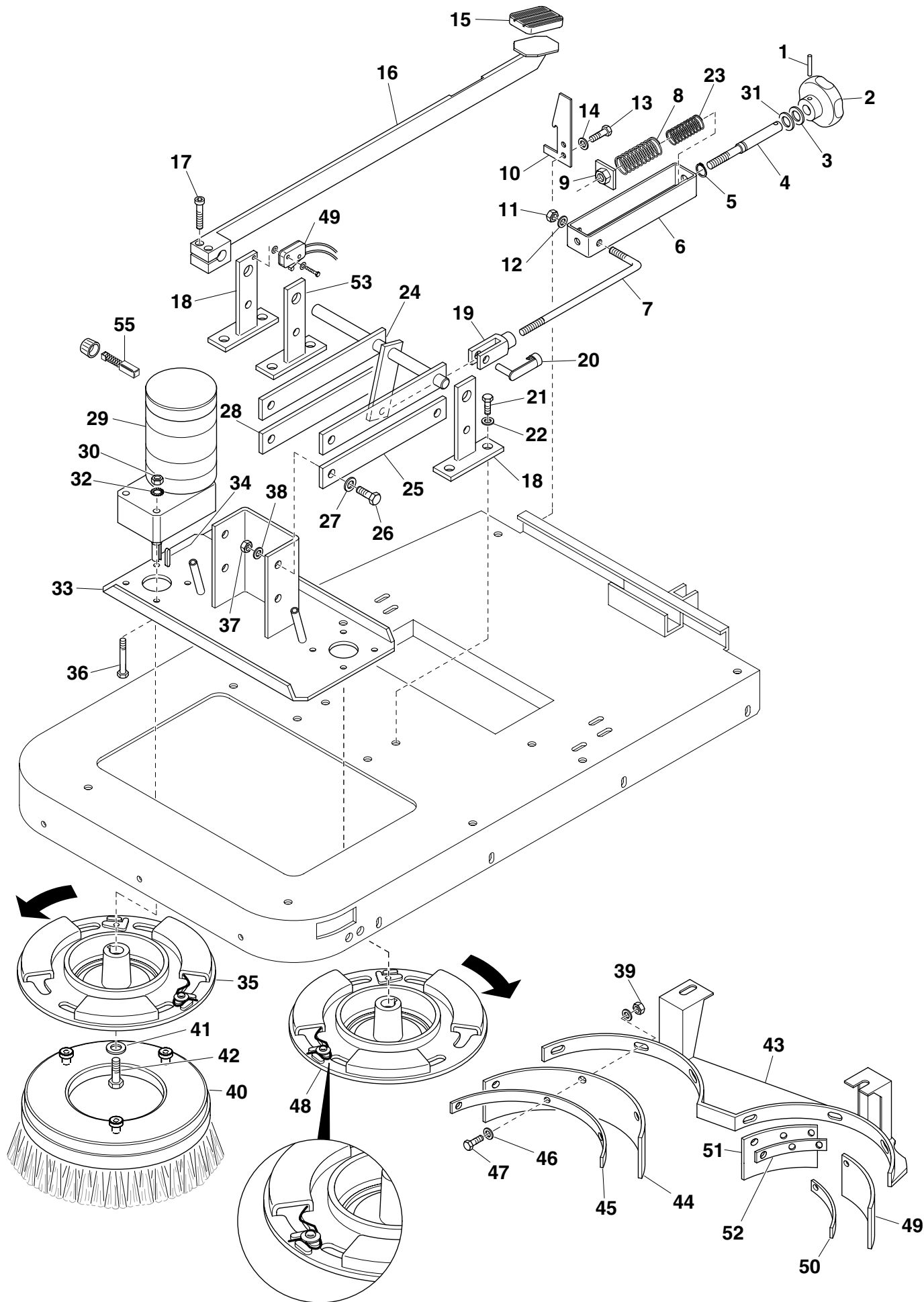

TAV. C / DRAW. C / VUE C / ZEICHN. C

AW465 S32EM465(4)99-01

POSIZ. ITEM POS. EINSAT.	CODICE CODE CODE NUMMER	CODICE INTERNO INTERNAL CODE CODE INTERIEUR INTERNE NUMMER	DESCRIZIONE DESCRIPTION DESCRIPTION BEZEICHNUNG	B	O
1	145 1704 000	H06.03800	TUBO / PIPE / TUYAU / SCHLAUCH	2	
2	145 8497 000	R4DA0L020	KIT TAPPO ACQUA / CAP / BOUCHON / PFROPFEN	2	
3	145 8575 000	V20.02100	FASCETTA / CLAMP / COLLIER / PASSRING	2	
4	145 8574 000	F04.13900	TUBO / PIPE / TUYAU / SCHLAUCH	2	
5	145 9959 000	V02.00310	VITE / SCREW / VIS / SCHRAUBE	6	
6	145 0252 000	V19.00410	RONDELLA / WASHER / RONDELLE / BEILAGESCHEIBE	6	
7	145 9961 000	V09.00410	RONDELLA / WASHER / RONDELLE / BEILAGESCHEIBE	6	
8	145 0545 000	H04.08500	GUARNIZIONE / GASKET / JOINT / DICHTUNG	2	
9	145 4566 000	X60.008AA	TUBO ASPIR. / VACUUM HOSE / TUYAU / SAUGSCHLAUCH	1	
10	145 4567 000	X60.009AA	TERMINALE TUBO ASP. / TERMINAL / TERMINAL / TERMINAL	1	
11	145 8494 000	G05.09200	SENSORE / SENSOR / SENSOR / SENSOR	1	
12	145 0566 000	E02.68100	FLANGIA / FLANGE / FLASQUE / FLANSCH	1	
13	145 0492 000	V02.00510	VITE / SCREW / VIS / SCHRAUBE	3	
14	145 0246 000	V09.02210	RONDELLA / WASHER / RONDELLE / BEILAGESCHEIBE	6	
15	145 9934 000	V13.01910	DADO / NUT / ECROU / MUTTER	3	
16	145 8869 000	A03.08500	POMPA / PUMP / POMPE / PUMPE	1	
17	145 8580 000	E02.61800	PASSAPARATIA / PIPE FITTING / CLOISON / VERBINDUNG	1	
18	145 0535 000	V20.04800	FASCETTA / CLAMP / COLLIER / PASSRING	2	
19	145 1352 000	H05.08790	TUBO / PIPE / TUYAU / SCHLAUCH	1	
20	145 9942 000	G02.12900	GRUPPO ELETTROVALVOLE / ELECTROVALVE / ELECTROVALVE / ELEKTROVENTIL	1	
21	145 0531 000	F03.64100	SUPPORTO / SUPPORT / SUPPORT / HALTER	1	
22	145 0532 000	V01.03210	VITE / SCREW / VIS / SCHRAUBE	2	
23	145 0530 000	M03.25400	PORTAGOMMA / PIPE HOLDER / RACCORD / GUMMIHALTER	2	
24	145 0534 000	H04.10000	GUARNIZIONE / GASKET / JOINT / DICHTUNG	2	
25	145 4166 000	H05.07200	TUBO / PIPE / TUYAU / SCHLAUCH	1	
26	145 1731 000	H05.06100	TUBO / PIPE / TUYAU / SCHLAUCH	1	
27	145 0535 000	V20.04800	FASCETTA / CLAMP / COLLIER / PASSRING	8	
29	145 8588 000	E04.08200	MOLLA / SPRING / RESSORT / FEDER	1	
30	145 8589 000	H03.06300	TUBO / PIPE / TUYAU / SCHLAUCH	1	
31	145 1712 000	H06.03890	TUBO / PIPE / TUYAU / SCHLAUCH	1	
32	145 0541 000	V20.01200	FASCETTA / CLAMP / COLLIER / PASSRING	3	
33	145 1708 000	H06.03850	TUBO / PIPE / TUYAU / SCHLAUCH	1	
34	145 0543 000	V20.04500	FASCETTA / CLAMP / COLLIER / PASSRING	2	
35	145 0411 000	H08.00060	CONVOGLIATORE / CONVEYOR / VONVOYEUR / BEFÖRDERN	1	
36	145 8265 000	A00.07000	MOTORE / MOTOR / MOTEUR / MOTOR	1	
37	145 3516 000	F03.68000	SUPPORTO / SUPPORT / SUPPORT / HALTER	1	
38	145 8007 000	L02.15700	ANTIVIBR. / VIBRATION DAMPING / SILENT BLOC / SCHWINGUNGSDAMP.	2	
39	145 9960 000	V13.00410	DADO / NUT / ECROU / MUTTER	2	
40	145 9960 000	V13.00410	DADO / NUT / ECROU / MUTTER	2	
41	145 9959 000	V02.00310	VITE / SCREW / VIS / SCHRAUBE	2	
42	145 0246 000	V09.02210	RONDELLA / WASHER / RONDELLE / BEILAGESCHEIBE	2	
43	145 0252 000	V19.00410	RONDELLA / WASHER / RONDELLE / BEILAGESCHEIBE	2	
44	145 1623 000	E08.15220	GUAINA / SHEATH / GAINÉ / MANTEL	1	
45	145 8551 000	E04.06500	MOLLA / SPRING / RESSORT / FEDER	1	
46	145 1705 000	H06.03820	TUBO / PIPE / TUYAU / SCHLAUCH	1	
47	145 0565 000	H04.10590	GUARNIZIONE OR / GASKET / JOINT / DICHTUNG	1	

TAV. C / DRAW. C / VUE C / ZEICHN. C

AW465

S32EM465(4)99-01

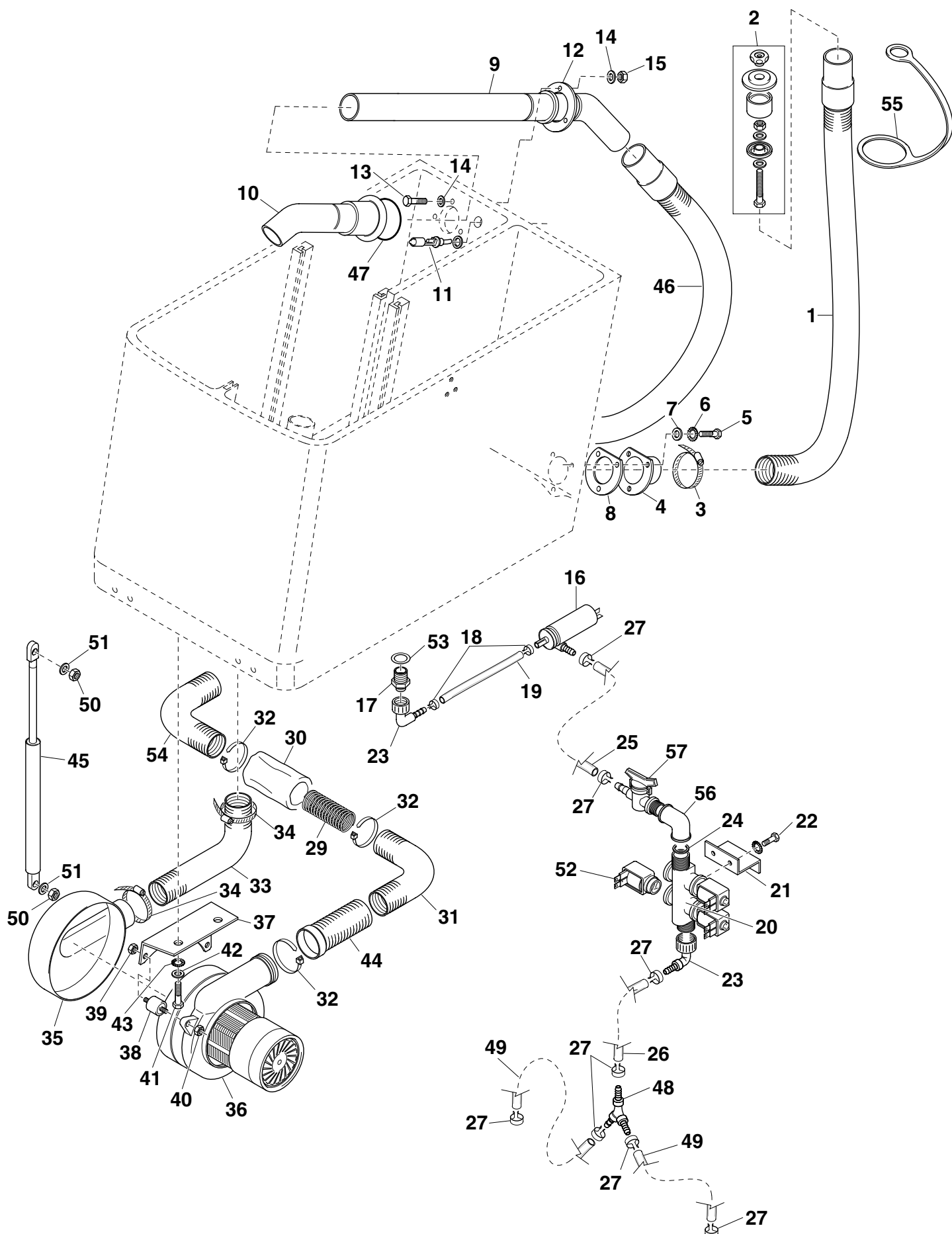

TAV. E / DRAW. E / VUE E / ZEICHN. E

AW465 S32EM465(4)99-01

POSIZ. ITEM POS. EINSAT.	CODICE CODE CODE NUMMER	CODICE INTERNO INTERNAL CODE CODE INTERIEUR INTERNE NUMMER	DESCRIZIONE DESCRIPTION DESCRIPTION BEZEICHNUNG	B	O
1	145 8568 000	L02.09500	MANOPOLA / KNOB / POIGNEE / DREHKNOPF	2	
2	145 0406 000	L02.15600	COMANDO / CONTROL / COMMANDE / BETÄTIGUNG	2	
3	145 8567 000	E02.62400	MANOPOLA / KNOB / POIGNEE / DREHKNOPF	1	
4	145 8455 000	L02.14500	VOLANTINO / KNOB / MOLETTE / HANDRAD	1	
5	145 8530 000	H01.21200	CARTER / CRANKCASE / CARTER / GEHÄUSE	1	
6	145 1152 000	F04.20300	MANUBRIO / HANDLE / GUIDON / LENKER	1	
7	145 8221 000	G05.04900	MICROINT. / MICROSWITCH / MICROINTERRUPTEUR / MICROSCHALTER	1	
8	145 8221 000	G05.04900	MICROINT. / MICROSWITCH / MICROINTERRUPTEUR / MICROSCHALTER	1	
9	145 9138 000	V09.001	RONDELLA / WASHER / RONDELLE / BEILAGESCHEIBE	6	
10	145 0520 000	V13.06010	DADO / NUT / ECROU / MUTTERTER	4	
11	145 0529 000	V01.005	VITE / SCREW / VIS / SCHRAUBE	2	
12	145 1161 000	F03.69370	STAFFA / HANGER / ETRIER / BÜGEL	1	
13	145 8532 000	E02.63600	MARGHERITA / COG WHEEL / ENGRENAGES / ZAHNRAD	1	
14	145 8531 000	F03.46500	CHIUSURA / PROTECTION SIDE PLATE / FERMETURE / VERSCHLUSS	1	
15	145 0572 000	V03.05010	VITE / SCREW / VIS / SCHRAUBE	3	
16	145 0246 000	V09.02210	RONDELLA / WASHER / RONDELLE / BEILAGESCHEIBE	2	
17	145 0498 000	V02.00210	VITE / SCREW / VIS / SCHRAUBE	2	
18	145 1583 000	G13.19540	POTENZIOMETRO / POTENTIOMETER / POTENTIOMETRE / POTENTIOMETER	1	
19	145 8570 000	E04.08100	MOLLA / SPRING / RESSORT / FEDER	1	
20	145 1160 000	V05.01910	VITE / SCREW / VIS / SCHRAUBE	1	
21	145 1154 000	H08.00010	BIELLA / CONNECTING ROD / BIELLE / FLUEGELSTANGE	1	
22	145 1155 000	H08.00020	LEVA / LEVER / LEVIER / HEBEL	1	
23	145 1162 000	V02.09803	VITE / SCREW / VIS / SCHRAUBE	2	
24	145 8490 000	L02.13300	CAMMA / CAM / CAME / KAMM	1	
25	145 8261 000	G05.10700	INTERRUTTORE / SWITCH / INTERRUPTEUR / SCHALTER	1	

TAV. E / DRAW. E / VUE E / ZEICHN. E

AW465

S32EM465(4)99-01

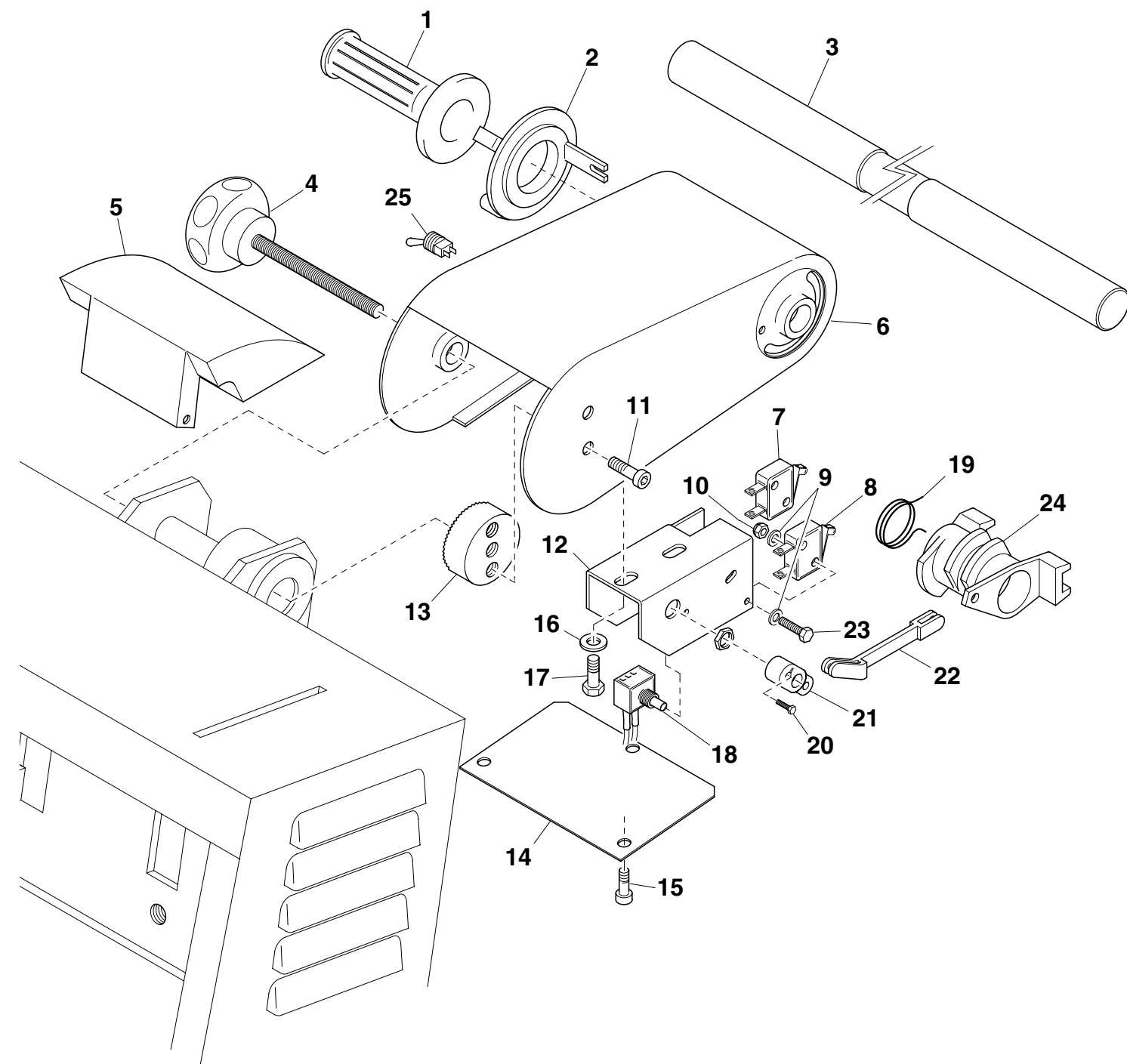

TAV. C / DRAW. C / VUE C / ZEICHN. C

AW465 S32EM465(4)99-01

POSIZ. ITEM POS. EINSAT.	CODICE CODE CODE NUMMER	CODICE INTERNO INTERNAL CODE CODE INTERIEUR INTERNE NUMMER	DESCRIZIONE DESCRIPTION DESCRIPTION BEZEICHNUNG	B	O
48	145 8224 000	M03.25510	PORTAGOMMA / PIPE HOLDER / RACCORD / GUMMIHALTER	1	
49	145 4159 000	H05.05200	TUBO / PIPE / TUYAU / SCHLAUCH	2	
50	145 9978 000	V13.00510	DADO / NUT / ECROU / MUTTER	2	
51	145 8396 000	V19.00510	RONDELLA / WASHER / RONDELLE / BEILAGESCHEIBE	2	
52	145 8503 000	G02.12400	SOLENOIDE / SOLENOID / SOLENOIDE / SOLENOID	3	
53	145 0423 000	H04.10510	GUARNIZIONE OR / GASKET / JOINT / DICHTUNG	1	
54	145 1707 000	H06.03840	TUBO / PIPE / TUYAU / SCHLAUCH	1	
55	145 4911 000	-	GOMMA / RUBBER / CAOUTCHOU / GUMMI	2	
56	145 5016 000	-	RACCORDO A 90° 1/2" / CONNECTOR / RACCORD / ANSCHLUß	1	
57	145 5015 000	-	RUBINETTO 1/2" / PLUG COCK / ROBINET / HAHN	1	

TAV. D / DRAW. D / VUE D / ZEICHN. D

AW465

S32EM465(4)99-01

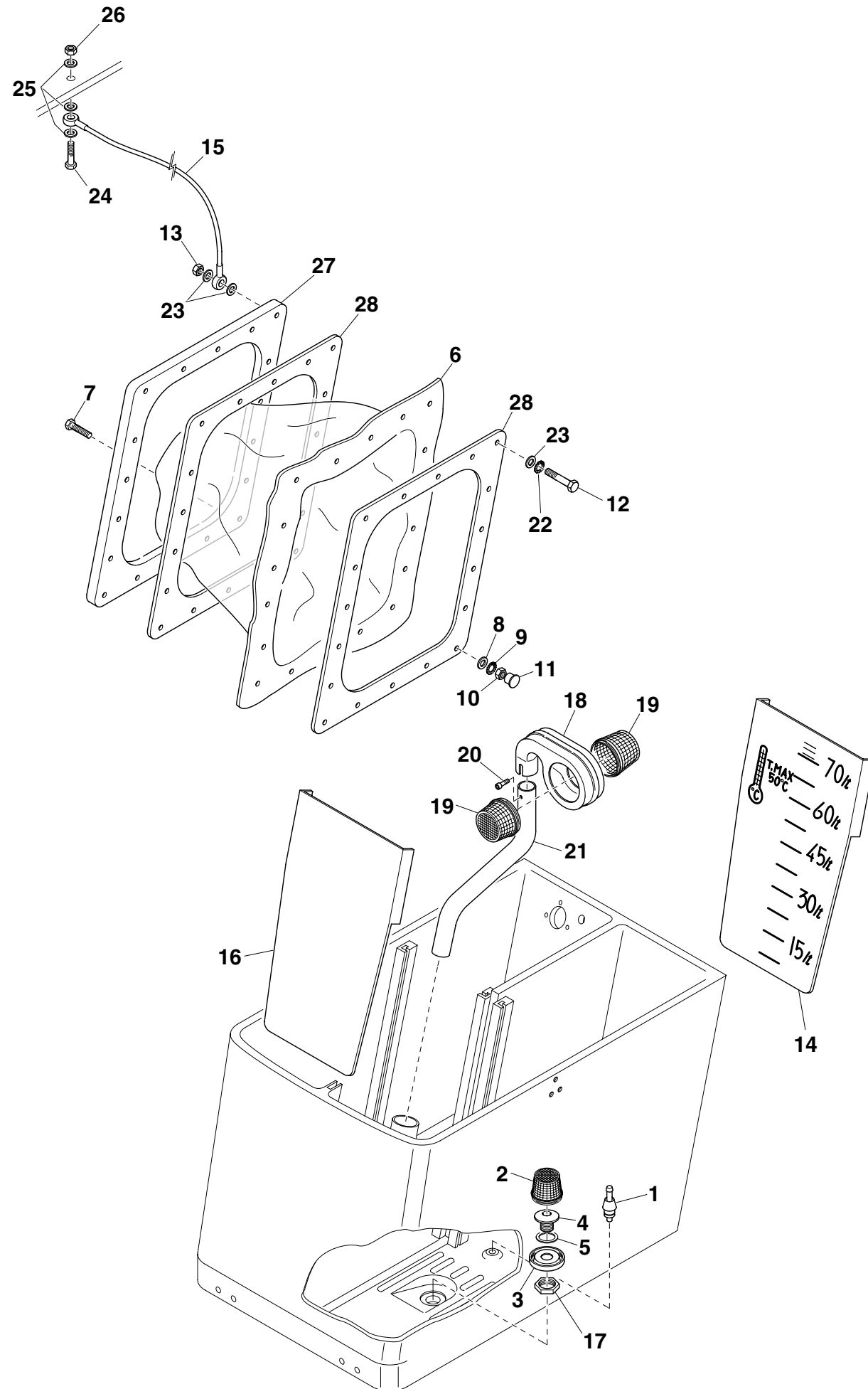

TAV. D / DRAW. D / VUE D / ZEICHN. D

AW465 S32EM465(4)99-01

POSIZ. ITEM POS. EINSAT.	CODICE CODE CODE NUMMER	CODICE INTERNO INTERNAL CODE CODE INTERIEUR INTERNE NUMMER	DESCRIZIONE DESCRIPTION DESCRIPTION BEZEICHNUNG	B	O
1	145 0558 000	G05.11140	SENSORE / SENSOR / SENSOR / SENSOR	1	
2	145 0394 000	H08.00100	FILTRO / FILTER / FILTRE / FILTER	1	
3	145 0410 000	H08.00110	BASE CESTINO DI FONDO / SUPPORT / SUPPORT / HALTER	1	
4	145 0422 000	H08.00160	RACCORDO / CONNECTOR / RACCORD / ANSCHLUß	1	
5	145 0536 000	H04.10580	GUARNIZIONE / GASKET / JOINT / DICHTUNG	1	
6	145 0289 000	H02.34460	MEMBRANA / MEMBRANE / MEMBRANE / MEMBRAN	1	
7	145 0553 000	V02.00610	VITE / SCREW / VIS / SCHRAUBE	17	
8	145 0246 000	V09.02210	RONDELLA / WASHER / RONDELLE / BEILAGESCHEIBE	18	
9	145 0252 000	V19.00410	RONDELLA / WASHER / RONDELLE / BEILAGESCHEIBE	18	
10	145 0554 000	V13.09630	DADO / NUT / ECROU / MUTTER	18	
11	145 4618 000	-	COPRIDADO / COVER FOR NUT / COUVRE-ECROU / MUTTERTERKASTEN	18	
12	145 0555 000	V02.07810	VITE / SCREW / VIS / SCHRAUBE	1	
13	145 9960 000	V13.00410	DADO / NUT / ECROU / MUTTER	1	
14	145 4191 000	H08.00180	PARATIA SX / BUFFLE / CLOISON / SCHOTT	1	
15	145 8498 000	E08.13000	CAVO / CABLE / CABLE / KABEL	1	
16	145 4192 000	H08.00190	PARATIA / DIVIDING PLATE / CLOISON / SCHOTT DX	1	
17	145 8578 000	V13.07120	GHIERA / NUT / ECROU / RING	1	
18	145 0396 000	H01.25930	PROTEZIONE / GUARD / PROTECTION / SCHUTZ	1	
19	145 0394 000	H08.00100	FILTRO / FILTER / FILTRE / FILTER	2	
20	145 0172 000	V04.05060	VITE / SCREW / VIS / SCHRAUBE	1	
21	145 8492 000	H05.03600	TUBO ASPIR. / VACUUM HOSE / TUYAU / SAUGSCHLAUCH	1	
22	145 0252 000	V19.00410	RONDELLA / WASHER / RONDELLE / BEILAGESCHEIBE	1	
23	145 0246 000	V09.02210	RONDELLA / WASHER / RONDELLE / BEILAGESCHEIBE	3	
24	145 0245 000	V02.08410	VITE / SCREW / VIS / SCHRAUBE	1	
25	145 0246 000	V09.02210	RONDELLA / WASHER / RONDELLE / BEILAGESCHEIBE	5	
26	145 9934 000	V13.01910	DADO / NUT / ECROU / MUTTER	1	
27	145 0584 000	F01.21500	TELAIO / FRAME / CHASSIS / RAHMEN	1	
28	145 0335 000	H04.10530	GUARNIZIONE / GASKET / JOINT / DICHTUNG	2	