

SWEeper
SW 700 P/B
SW 5070 P/B

PARTS

S32NM5070(3A)99-11

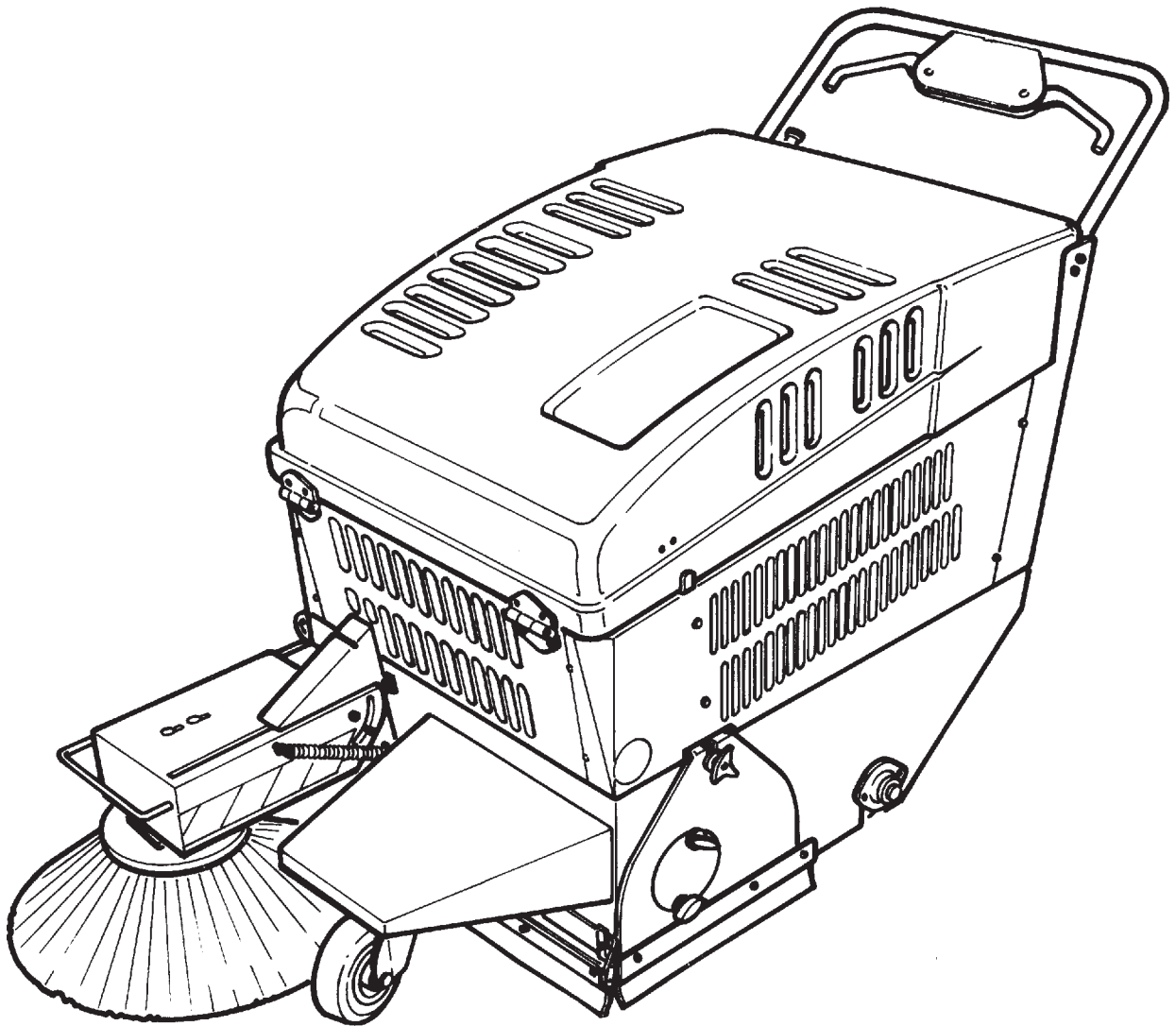

Catalogo ricambi
Spare parts list
Liste des pieces detachees
Ersatzteilliste

ACCESSORIO
 OPTIONAL
 ACCESSOIRES
 ZUBEHÖR

VERSIONE A BENZINA
 FUEL VERSION
 MODELE A CARBURANT
 BENZINVERSION

VERSIONE A BATTERIA
 BATTERY VERSION
 VERSION A BATTERIE
 BATTERIE MODELL

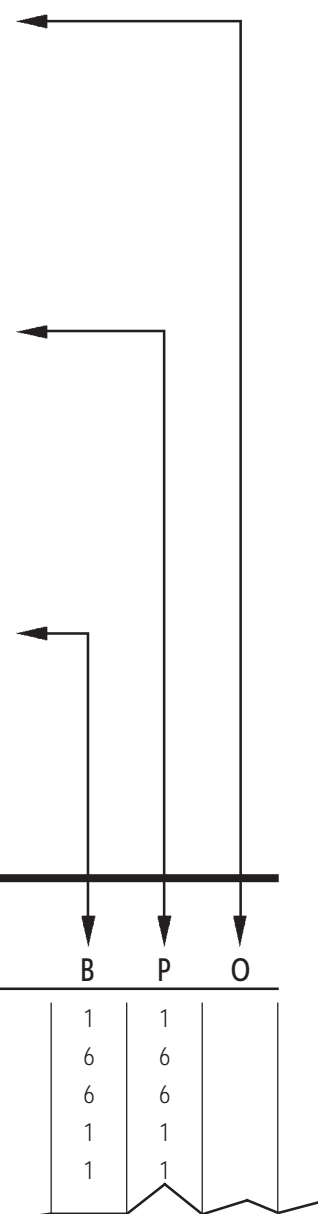

POSIZ. ITEM POS. EINSAT.	CODICE CODE CODE NUMMER	CODICE INTERNO INTERNAL CODE CODE INTERIEUR INTERNE NUMBER	DESCRIZIONE DESCRIPTION DESCRIPTION BEZEICHNUNG	B	P	O
5		F00.65600	PARAURTI / MOUNTING BRAKET / PARACHOCS / STOSSDAEMPFER	1	1	
6		V11.02200	RONDELLA / WASHER / RONDELLE / BEILAGSCHEIBE	6	6	
7		V03.044	VITE / SCREW / VIS / SCHRAUBE	6	6	
8		H02.34670	TAPPETINO / MAT BOARD / TAPIS / TEPPICH	1	1	
9		F00.62200	PIANTONE / COLUMN / COLONNE / LENKROHR	1	1	

WHEN ORDERING PARTS

- * Specify the model and serial number of the machine.
- * Use the space below to record the model and serial number for future reference.

Model _____ Serial No. _____

TAV. A / DRAW. A / VUE A / ZEICHN. A

SW 700 - SW 5070

S32NM5070(3A)99-11

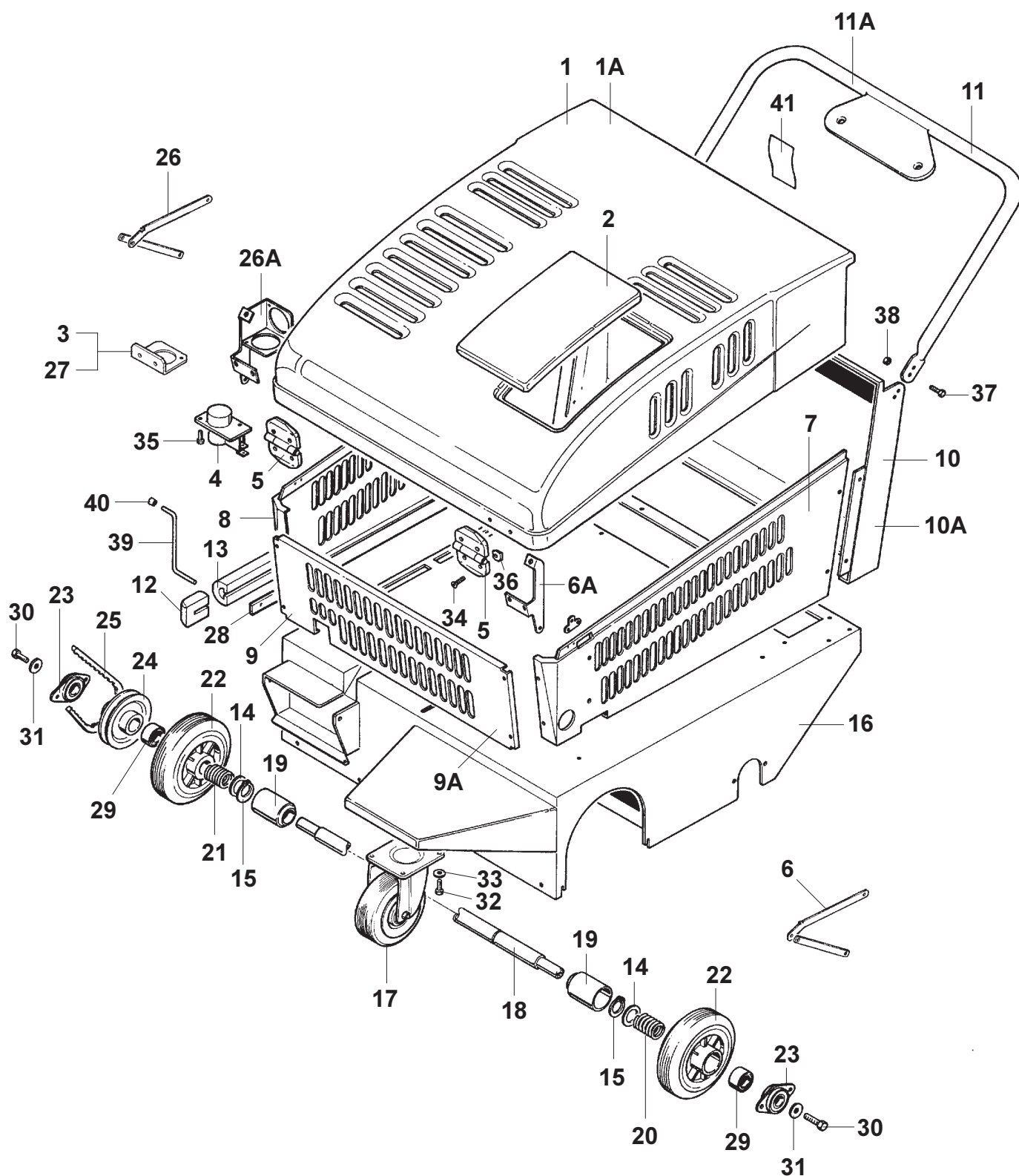

TAV. A / DRAW. A / VUE A / ZEICHN. A

POSIZ. ITEM POS. EINSAT.	CODICE CODE CODE NUMMER	CODICE INTERNO INTERNAL CODE CODE INTERIEUR INTERNE NUMMER	DESCRIZIONE DESCRIPTION DESCRIPTION BEZEICHNUNG	SW 700 - SW 5070 S32NM5070(3A)99-11		
				B	P	O
1	145 4645 000	-	COFANO MOTORE / BONNET / CAPOTAGE / MOTORHAUBE (BLUE)	1	1	
1A	145 4648 000	-	COFANO MOTORE / BONNET / CAPOTAGE / MOTORHAUBE (GREY 7001)	1	1	
2	145 4816 000	-	TAPPO / CAP / BOUCHON / PFROPFEN	1		
3	145 4681 000	-	STAFFA / HANGER / ETRIER / BUGEL		1	
4	145 4820 000	-	MICROINT. / MICROSWITCH / MICROINTERRUPTEUR / MICROSCHALTER	1	1	
5	145 0399 000	L02.16080	CERNIERA / HINGE / CHARNIERE / SCHARNIER	2	2	
6	145 4815 000	-	LEVA COFANO / LEVER / LEVIER / HEBEL SX	1	1	
6A	145 6030 000	-	LEVA COFANO / LEVER / LEVIER / HEBEL SX	1	1	
7	145 1936 000	-	FIANCHETTO SX / SIDE FRAME / PANNEAU / WANGE	1	1	
8	145 1937 000	-	FIANCHETTO DX / SIDE FRAME / PANNEAU / WANGE	1	1	
9	145 1938 000	-	FRONTALE / FRONT PANEL / PANNEAU AV. / VORDER PANEL	1	1	
9A	145 6042 000	-	FRONTALE / FRONT PANEL / PANNEAU AV. / VORDER PANEL	1	1	
10	145 1932 000	-	SUPPORTO MANIGLIONE / HANDLE SUPPORT / SUPPORT POIGNE / HANDGRIFFHALTER	1	1	
10A	145 6040 000	-	SUPPORTO MANIGLIONE / HANDLE SUPPORT / SUPPORT POIGNE / HANDGRIFFHALTER	1	1	
11	145 4742 000	-	MANIGLIONE / HANDLE / POIGNE / HANDGRIFF	1	1	
11A	45 6041 000	-	MANIGLIONE / HANDLE / POIGNE / HANDGRIFF	1	1	
12	145 4640 000	-	TERMINALE PARACOLPI / BUMPER END / EXTRÉMITÉ DE LA BARRE ANTI-CHOC / ENDE DES GUMMIPUFFERS			2
13	145 4851 000	-	PROTEZIONE / GUARD / PROTECTION / SCHUTZ			1
14	145 4291 000	M03.021	GUARNIZIONE / GASKET / JOINT / DICHTUNG	4	4	
15	145 9275 000	V14.009	SEEGER / RETAINING RING / CIRCLIPS / SICHERUNGSRING	2	2	
16	145 1927 000	-	TELAIO / FRAME / CHASSIS / RAHMEN	1	1	
17	145 5115 000	-	RUOTA / WHEEL / ROUE / RAD	1	1	
18	145 4737 000	-	ALBERO / SHAFT / ARBRE / WELLE	1	1	
19	145 4741 000	-	COPRI MOLLA / SPRING COVER / HOUSSE RESSORT / FEDERDECKUNG	2	2	
20	145 4739 000	-	MOLLA SX / SPRING / HOUSSE / FEDER	1	1	
21	145 4740 000	-	MOLLA DX / SPRING / HOUSSE / FEDER	1	1	
22	145 5324 000	-	RUOTA / WHEEL / ROUE / RAD	2	2	
23	145 8015 000	C04.01900	SUPPORTO / SUPPORT / SUPPORT / HALTER	2	2	
24	145 4738 000	-	PULEGGIA / PULLEY / POULIE / SCHEIBE	1	1	
25	145 5306 000	-	CINGHIA / BELT / COURROIE / RIEMEN	1	1	
26	145 5062 000	-	LEVA COFANO / LEVER / LEVIER / HEBEL DX	1	1	
26A	145 6031 000	-	LEVA COFANO / LEVER / LEVIER / HEBEL DX	1	1	
27	145 4817 000	-	STAFFA / HANGER / ETRIER / BUGEL	1		
28	145 4753 000	-	PIATTINA / PLATE / PLAQUE / BAND			1
29	145 4801 000	-	CUSCINETTO / BALL BEARING / ROULEMENT / LAGER	2	2	
30	145 9115 000	V02.012	VITE / SCREW / VIS / SCHRAUBE	2	2	
31	145 9120 000	V09.005	RONDELLA / WASHER / RONDELLE / BEILAGSCHEIBE	2	2	
32	145 9170 000	V02.013	VITE / SCREW / VIS / SCHRAUBE	4	4	
33	145 9213 000	V09.020	RONDELLA / WASHER / RONDELLE / BEILAGSCHEIBE	4	4	
34	145 0569 000	V04.05090	VITE / SCREW / VIS / SCHRAUBE	4	4	
35	145 1163 000	V03.06200	VITE / SCREW / VIS / SCHRAUBE	2	2	
36	145 9287 000	V13.018	DADO / NUT / ECROU / MUTTER	4	4	
37	145 9286 000	V04.01500	VITE / SCREW / VIS / SCHRAUBE	4	4	
38	145 9132 000	V13.019	DADO / NUT / ECROU / MUTTER	4	4	
39	145 6034 000	-	TIRANTE / TENSION ROD / TIRANT / ZUGSTANGE	2	2	
40	145 6024 000	-	COPRIPERNO / PIN-CAP / COUVRE-PIVOT / BOLZENDECKEL	4	4	
41	145 6059 000	-	DECALCOMANIA / WARNING PLATE / PLAQUETTE / BESCHILDERUNG	1		

TAV. B / DRAW. B / VUE B / ZEICHN. B

SW 700 - SW 5070

S32NM5070(3)99-09

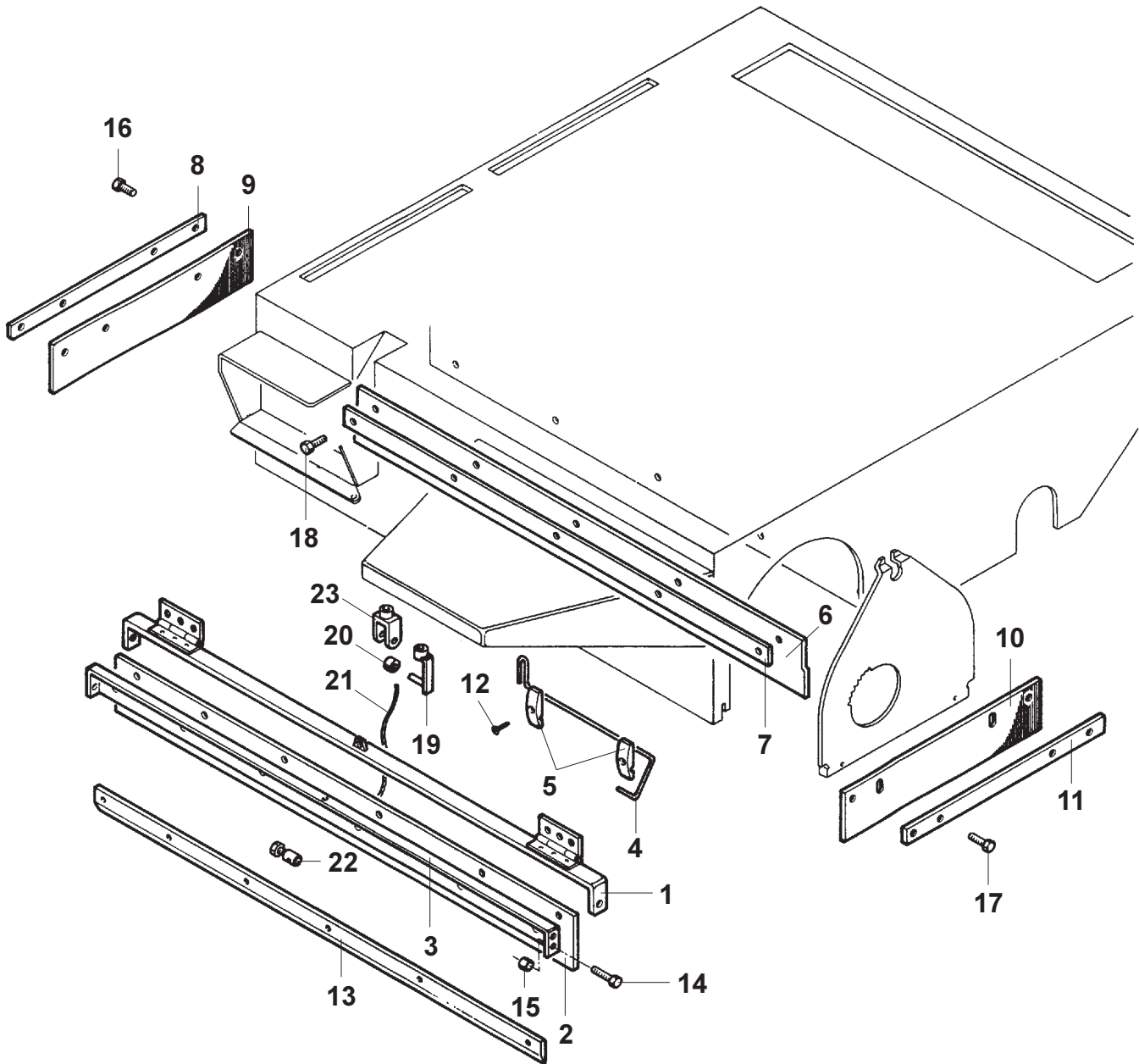

TAV. B / DRAW. B / VUE B / ZEICHN. B

POSIZ. ITEM POS. EINSAT.	CODICE CODE CODE NUMMER	CODICE INTERNO INTERNAL CODE CODE INTERIEUR INTERNE NUMMER	DESCRIZIONE DESCRIPTION DESCRIPTION BEZEICHNUNG	SW 700 - SW 5070 S32NM5070(3)99-09		
				B	P	O
1	145 1925 000	-	PORTA ALZAFLAP / SUPPORT / SUPPORT / HALTER	1	1	
2	145 4760 000	-	FLAP ANTERIORE / FRONT FLAP / BAVETTE ANT. / VORDER FLAP GUMMI	1	1	
3	145 1924 000	-	ALZAFLAP / SUPPORT / SUPPORT / HALTER	1	1	
4	145 4735 000	-	MOLLA / SPRING / HOUSSE / FEDER	2	2	
5	145 1180 000	H01.26340	PIATTINA / PLATE / PLAQUE / BAND	4	4	
6	145 4761 000	-	FLAP POSTERIORE / REAR FLAP / BAVETTE AR / HINTERE FLAP GUMMI	1	1	
7	145 4757 000	-	PIATTINA FLAP POST. / PLATE / PLAQUE / BAND	1	1	
8	145 4758 000	-	PIATTINA FLAP DX / PLATE / PLAQUE / BAND	1	1	
9	145 4762 000	-	FLAP / FLAP / BAVETTE / FLAP GUMMI DX	1	1	
10	145 5004 000	-	FLAP / FLAP / BAVETTE / FLAP GUMMI SX	1	1	
11	145 4759 000	-	PIATTINA FLAP SX / PLATE / PLAQUE / BAND	1	1	
12	145 9211 000	V05.001	VITE / SCREW / VIS / SCHRAUBE	4	4	
13	145 1926 000	-	PIATTINA FLAP ANT. / PLATE / PLAQUE / BAND	1	1	
14	145 9135 000	V02.023	VITE / SCREW / VIS / SCHRAUBE	2	2	
15	145 9287 000	V13.018	DADO / NUT / ECROU / MUTTER	2	2	
16	145 5063 000	V05.00603	VITE / SCREW / VIS / SCHRAUBE	4	4	
17	145 9261 000	V02.003	VITE / SCREW / VIS / SCHRAUBE	2	2	
18	145 5063 000	V05.00603	VITE / SCREW / VIS / SCHRAUBE	3	3	
19	145 9402 000	V17.06500	CLIPS / CLIPS / CLIPS / CLIPS	1	1	
20	145 1252 000	E05.19170	DISTANZIALE / SPACER / ENTRETOISE / ABSTANDSSTÜCK	1	1	
21	145 5071 000	-	CAVO / CABLE / CABLE / KABEL	1	1	
22	145 8110 000	E08.010	MORSETTO / CLAMP / SERRE CABLE / BÜGEL	2	2	
23	145 5186 000	-	FORCELLA / FORK / FOURCHETTE / GABEL	1	1	

TAV. C / DRAW. C / VUE C / ZEICHN. C

SW 700 - SW 5070

S32NM5070(3)99-09

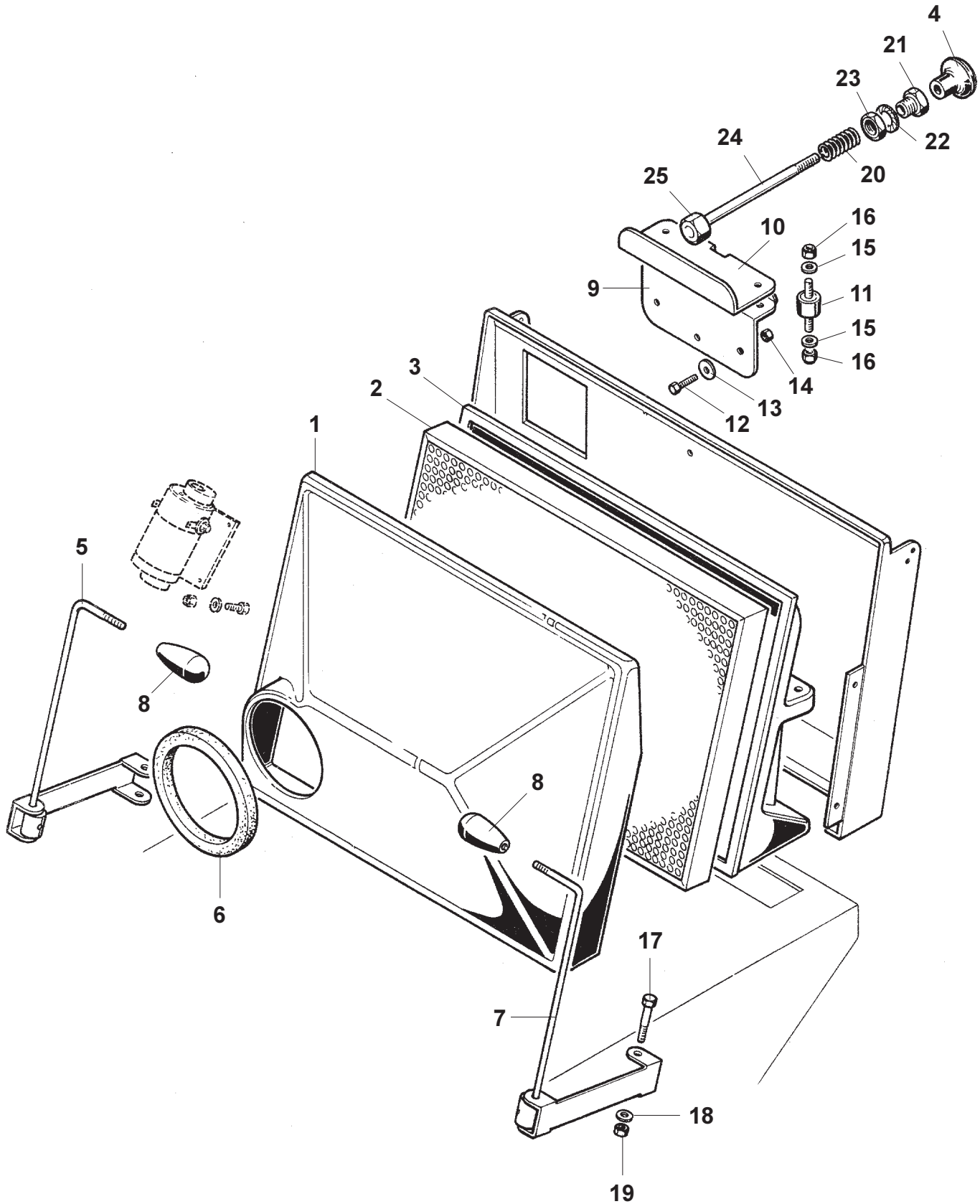

TAV. C / DRAW. C / VUE C / ZEICHN. C

POSIZ. ITEM POS. EINSAT.	CODICE CODE CODE NUMMER	CODICE INTERNO INTERNAL CODE CODE INTERIEUR INTERNE NUMMER	DESCRIZIONE DESCRIPTION DESCRIPTION BEZEICHNUNG	SW 700 - SW 5070 S32NM5070(3)99-09		
				B	P	O
1	145 4643 000	-	COPERCHIO / LID COVER / COUVERCLE / DECKEL	1	1	
2	145 4806 000	-	FILTRO / FILTER / FILTRE / FILTER	1	1	
3	145 4644 000	-	PORTAFILTRO / FILTER HOLDER / PORTE FILTRE / FILTERHALTER	1	1	
4	145 4802 000	-	POMELLO / KNOB / BOULE / KÜGELGRIFF	1	1	
5	145 1931 000	-	LEVA DX / LEVER / LEVIER / HEBEL	1	1	
6	145 5387 000	-	GUARNIZIONE / GASKET / JOINT / DICHTUNG	1	1	
7	145 1930 000	-	LEVA SX / LEVER / LEVIER / HEBEL	1	1	
8	145 9319 000	L03.02400	MANOPOLA / KNOB / POIGNEE / DREHKNOPF	2	2	
9	145 1933 000	-	PORTA SCUOTIFILTRO / FILTERSHAKER HOLDER / PORTE DECOLMATAGE DU FILTRE / FILTERRÜTLERHALTER	1	1	
10	145 1934 000	-	SCUOTIFILTRO / FILTERSHAKER / DECOLMATAGE DU FILTRE / FILTERRÜTLER	1	1	
11	145 8007 000	L02.15700	ANTIVIBRANTE / VIBRATION DAMPING / SILENT BLOC / SCHWINGUNGSDÄMP	2	2	
12	145 9261 000	V02.003	VITE / SCREW / VIS / SCHRAUBE	3	3	
13	145 9129 000	V09.012	RONDELLA / WASHER / RONDELLE / BEILAGSCHEIBE	3	3	
14	145 9132 000	V13.019	DADO / NUT / ECROU / MUTTER	3	3	
15	145 9233 000	V19.004	RONDELLA / WASHER / RONDELLE / BEILAGSCHEIBE	4	4	
16	145 9154 000	V13.004	DADO / NUT / ECROU / MUTTER	4	4	
17	145 0349 000	V02.008	VITE / SCREW / VIS / SCHRAUBE	2	2	
18	145 9128 000	V09.004	RONDELLA / WASHER / RONDELLE / BEILAGSCHEIBE	4	4	
19	145 9132 000	V13.019	DADO / NUT / ECROU / MUTTER	2	2	
20	145 1935 000	-	MOLLA / SPRING / HOUSSE / FEDER	1	1	
21	145 4928 000	-	GUIDA SCUOTIFILTRO / SLIDE / GUIDE / FÜHRUNGSBAHN	1	1	
22	145 4556 000	V19.006	RONDELLA / WASHER / RONDELLE / BEILAGSCHEIBE	1	1	
23	145 4515 000	V13.006	DADO / NUT / ECROU / MUTTER	1	1	
24	145 9623 000	V04.02703	VITE / SCREW / VIS / SCHRAUBE	1	1	
25	145 5020 000	-	DISTANZIALE / SPACER / ENTRETOISE / ABSTANDSSTÜCK	1	1	

TAV. D / DRAW. D / VUE D / ZEICHN. D

SW 700 - SW 5070

S32NM5070(3A)99-11

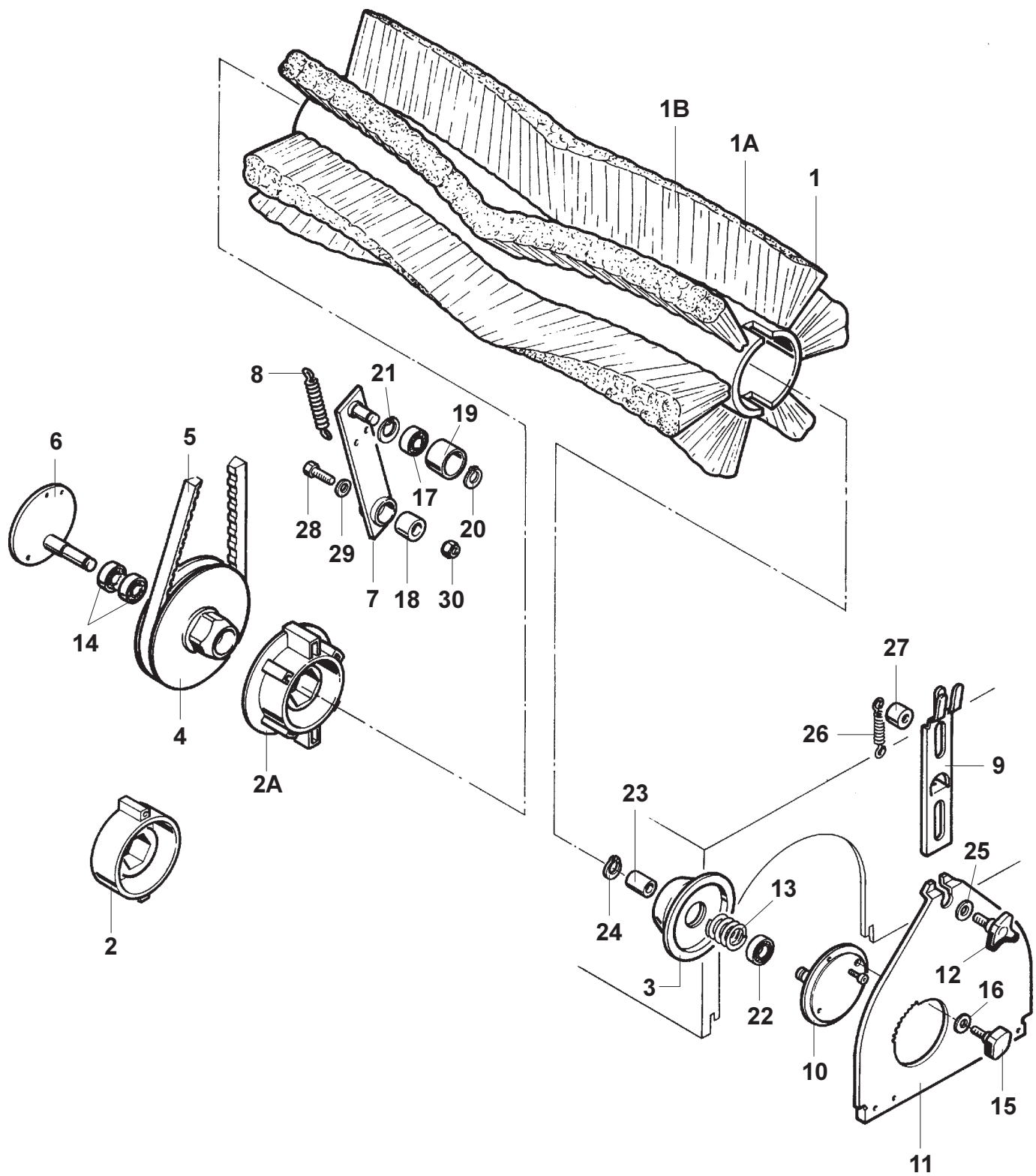

TAV. D / DRAW. D / VUE D / ZEICHN. D

POSIZ. ITEM POS. EINSAT.	CODICE CODE CODE NUMMER	CODICE INTERNO INTERNAL CODE CODE INTERIEUR INTERNE NUMMER	DESCRIZIONE DESCRIPTION DESCRIPTION BEZEICHNUNG	SW 700 - SW 5070 S32NM5070(3A)99-11		
				B	P	O
1	145 4792 000	-	SPAZZOLA / BRUSH / BROSSE / BÜRSTE	1	1	
1A	145 4973 000	-	SPAZZOLA CENTRALE MISTA ACCIAIO / CENTRAL BRUSH OF MIXED STEEL MATERIAL / BROSSE CENTRALE MIXTE EN ACIER / ZENTRALBÜRSTE AUS GEMISCHTEM STAHLMATERIAL			1
1B	145 4974 000	-	SPAZZOLA CENTRALE SAGGINA / BROOMCORN CENTRAL BRUSH / BROSSE CENTRALE EN SORGHO / ZENTRALBÜRSTE AUS BESENMOHRHIRSE			1
2	145 0268 000	E02.68880	MOZZO / HUB / MOYEU / NABE (DX)	1	1	
2A	145 5661 000	-	MOZZO / HUB / MOYEU / NABE (DX)	1	1	
3	145 0269 000	E02.68870	MOZZO / HUB / MOYEU / NABE (SX)	1	1	
4	145 2617 000	E03.18320	PULEGGIA / PULLEY / POULIE / SCHEIBE	1	1	
5	145 8199 000	H00.11700	CINGHIA / BELT / COURROIE / RIEMEN	1	1	
6	145 0272 000	E02.68860	PERNO / PIN / AXE / STIFT	1	1	
7	145 1210 000	F03.69270	LEVA / LEVER / LEVIER / HEBEL	1	1	
8	145 0274 000	E04.09490	MOLLA / SPRING / HOUSSE / FEDER	1	1	
9	145 1939 000	-	PIASTRINA / PLATE / PLAQUE / PLATTE	1	1	
10	145 0272 000	E02.68860	PERNO / PIN / AXE / STIFT	1	1	
11	145 1918 000	-	PORTELLO / HATCH / REGARD / Klappe	1	1	
12	145 2247 000	L02.16060	VOLANTINO / KNOB / MOLETTE / HANDRAD	1	1	
13	145 0271 000	E04.09460	MOLLA / SPRING / HOUSSE / FEDER	1	1	
14	145 0270 000	E00.023	CUSCINETTO / BALL BEARING / ROULEMENT / LAGER	2	2	
15	145 1211 000	L02.16050	VOLANTINO / KNOB / MOLETTE / HANDRAD	2	2	
16	145 9229 000	V09.022	RONDELLA / WASHER / RONDELLE / BEILAGSCHEIBE	2	2	
17	145 9186 000	E00.007	CUSCINETTO / BALL BEARING / ROULEMENT / LAGER	1	1	
18	145 9405 000	E01.007	BUSSOLA / BUSH / BAGUE / BUCHSE	1	1	
19	145 1209 000	E02.68910	RULLO / ROLLER / ROULEAU / ROLLE	1	1	
20	145 9259 000	V14.007	SEEGER / RETAINING RING / CIRCLIPS / SICHERUNGSRING	1	1	
21	145 9189 000	V14.013	SEEGER / RETAINING RING / CIRCLIPS / SICHERUNGSRING	1	1	
22	145 0270 000	E00.023	CUSCINETTO / BALL BEARING / ROULEMENT / LAGER	1	1	
23	145 2663 000	E05.12100	DISTANZIALE / SPACER / ENTRETOISE / ABSTANDSSTÜCK	1	1	
24	145 9187 000	V14.006	SEEGER / RETAINING RING / CIRCLIPS / SICHERUNGSRING	1	1	
25	145 9120 000	V09.005	RONDELLA / WASHER / RONDELLE / BEILAGSCHEIBE	1	1	
26	145 9290 000	E04.05200	MOLLA / SPRING / HOUSSE / FEDER	1	1	
27	145 1252 000	E05.19170	DISTANZIALE / SPACER / ENTRETOISE / ABSTANDSSTÜCK	2	2	
28	145 9170 000	V02.013	VITE / SCREW / VIS / SCHRAUBE	1	1	
29	145 9120 000	V09.005	RONDELLA / WASHER / RONDELLE / BEILAGSCHEIBE	1	1	
30	145 9123 000	V13.005	DADO / NUT / ECROU / MUTTER	1	1	

TAV. E / DRAW. E / VUE E / ZEICHN. E

SW 700 - SW 5070

S32NM5070(3A)99-11

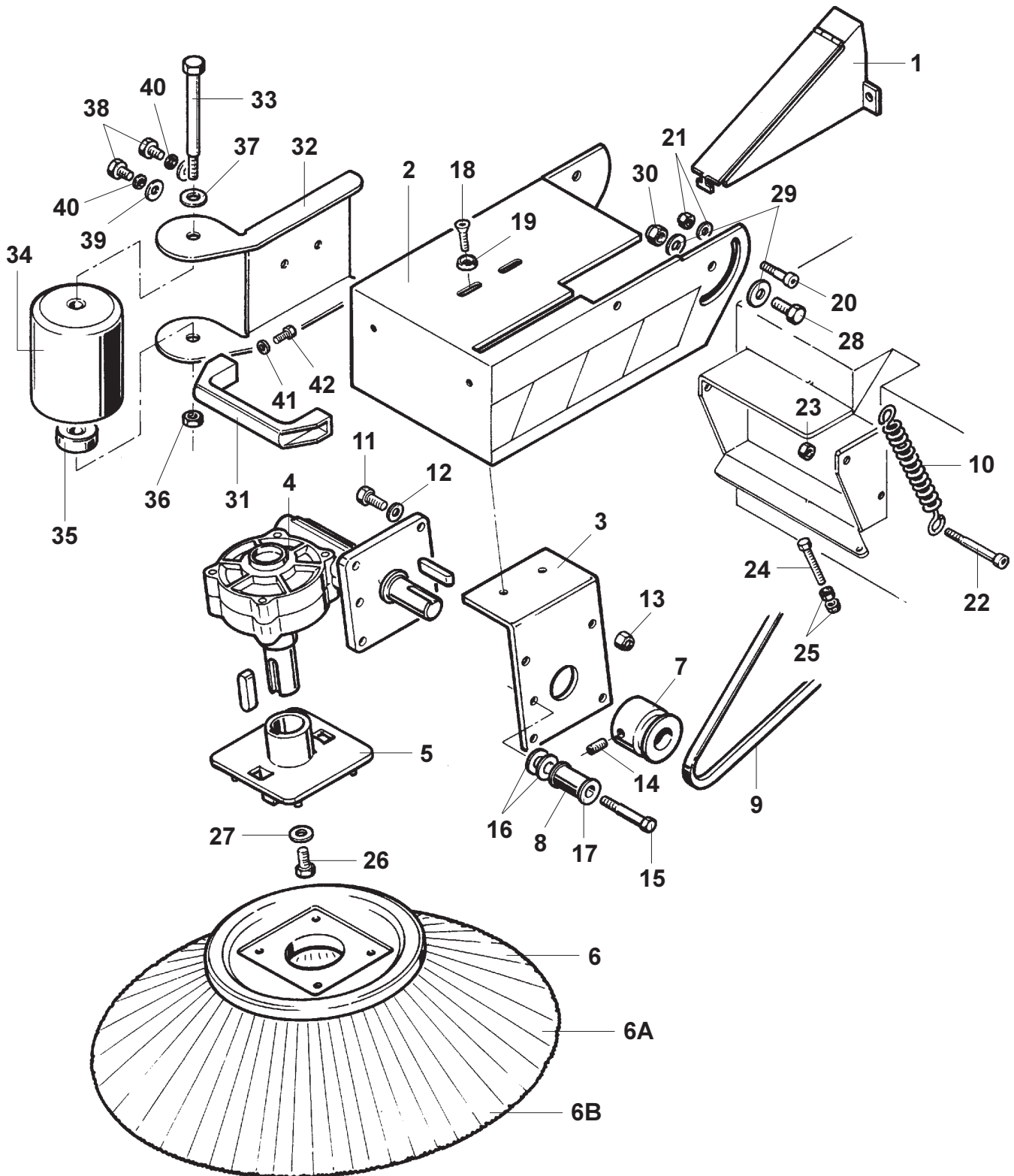

TAV. E / DRAW. E / VUE E / ZEICHN. E

POSIZ. ITEM POS. EINSAT.	CODICE CODE CODE NUMMER	CODICE INTERNO INTERNAL CODE CODE INTERIEUR INTERNE NUMMER	DESCRIZIONE DESCRIPTION DESCRIPTION BEZEICHNUNG	SW 700 - SW 5070 S32NM5070(3A)99-11		
				B	P	O
1	145 4748 000	-	PROTEZIONE / GUARD / PROTECTION / SCHUTZ	1	1	
2	145 6043 000	-	SUPPORTO / SUPPORT / SUPPORT / HALTER	1	1	
3	145 4750 000	-	STAFFA / HANGER / ETRIER / BÜGEL	1	1	
4	145 2324 000	C00.01502	RIDUTTORE / REDUCTION GEAR / RED. / VERMINDERUNGSGETRIEBE	1	1	
5	145 4812 000	-	FLANGIA / FLANGE / FLASQUE / FLANSCH	1	1	
6	145 1899 000	-	SPAZZOLA / BRUSH / BROSSSE / BÜRSTE	1	1	
6A	145 4976 000	-	SPAZZOLA LATERALE SAGGINA / BROOMCORN SIDE BRUSH / BROSSSE LATERALE EN SORGHO / SEITENBÜRSTE AUS BESENMOHRHIRSE			1
6B	145 4959 000	-	SPAZZOLA LATERALE MISTA ACCIAIO / SIDE BRUSH OF MIXED STEEL MATERIAL / BROSSSE LATERALE MIXTE EN ACIER / SEITENBÜRSTE AUS GEMISCHTEM STAHLMATERIAL			1
7	145 5470 000	-	PULEGGIA / PULLEY / POULIE / SCHEIBE	1	1	
8	145 1751 000	E05.19280	DISTANZIALE / SPACER / ENTRETOISE / ABSTANDSSTÜCK	1	1	
9	145 3848 000	H00.039	CINGHIA / BELT / COURROIE / RIEMEN	1	1	
10	145 4800 000	-	MOLLA / SPRING / HOUSSE / FEDER	1	1	
11	145 9141 000	V02.06700	VITE / SCREW / VIS / SCHRAUBE	4	4	
12	145 9237 000	V09.04200	RONDELLA / WASHER / RONDELLE / BEILAGSCHEIBE	4	4	
13	145 9125 000	V13.06100	DADO / NUT / ECROU / MUTTER	4	4	
14	145 4499 000	V08.00400	GRANO / DOWEL / GOUPILLE / STIFT	1	1	
15	145 1194 000	V02.005	VITE / SCREW / VIS / SCHRAUBE	1	1	
16	145 9128 000	V09.004	RONDELLA / WASHER / RONDELLE / BEILAGSCHEIBE	2	2	
17	145 1752 000	E05.19290	DISTANZIALE / SPACER / ENTRETOISE / ABSTANDSSTÜCK	2	2	
18	145 4488 000	V03.004	VITE / SCREW / VIS / SCHRAUBE	2	2	
19	145 9308 000	V11.02200	RONDELLA / WASHER / RONDELLE / BEILAGSCHEIBE	2	2	
20	145 0569 000	V04.05090	VITE / SCREW / VIS / SCHRAUBE	1	1	
21	145 9134 000	V13.003	DADO / NUT / ECROU / MUTTER	2	2	
22	145 0569 000	V04.05090	VITE / SCREW / VIS / SCHRAUBE	1	1	
23	145 9134 000	V13.003	DADO / NUT / ECROU / MUTTER	1	1	
24	145 9227 000	V02.004	VITE / SCREW / VIS / SCHRAUBE	1	1	
25	145 9154 000	V13.004	DADO / NUT / ECROU / MUTTER	1	1	
26	145 9261 000	V02.003	VITE / SCREW / VIS / SCHRAUBE	1	1	
27	145 9128 000	V09.004	RONDELLA / WASHER / RONDELLE / BEILAGSCHEIBE	1	1	
28	145 8005 000	V02.020	VITE / SCREW / VIS / SCHRAUBE	2	2	
29	145 9320 000	V09.006	RONDELLA / WASHER / RONDELLE / BEILAGSCHEIBE	4	4	
30	145 4515 000	V13.006	DADO / NUT / ECROU / MUTTER	2	2	
31	145 8461 000	L02.14000	MANIGLIA / HANDLE / POIGNEE / HANDGRIFF	1	1	
32	145 6033 000	-	STAFFA SUPPORTO RULLO / ROLLER SUPPORT HANGER / ETRIER SUPPORT ROULEAU / ROLLENTRAGBÜGEL			1
33	145 6008 000	-	VITE / SCREW / VIS / SCHRAUBE			1
34	145 6032 000	-	RULLO / ROLLER / ROULEAU / ROLLE			1
35	145 6036 000	-	DISTANZIALE / SPACER / ENTRETOISE / ABSTANDSSTÜCK			1
36	145 9167 000	V13.022	DADO / NUT / ECROU / MUTTER			1
37	145 9165 000	V09.007	RONDELLA / WASHER / RONDELLE / BEILAGSCHEIBE			1
38	145 9261 000	V02.003	VITE / SCREW / VIS / SCHRAUBE			2
39	145 9128 000	V09.004	RONDELLA STAFFA SUPPORTO RULLO / ROLLER SUPPORT HANGER WASHER / RONDELLE ETRIER SUPPORT ROULEAU / UNTERLEGSCHIEBE ROLLENTRAGBÜGEL			2
40	145 9228 000	V11.004	ROSETTA ELASTICA STAFFA SUPPORTO RULLO / ROLLER SUPPORT HANGER ELASTIC WASHER / RONDELLE ELASTIQUE ETRIER SUPPORT ROULEAU / FEDERSCHIEBE			2

TAV. E / DRAW. E / VUE E / ZEICHN. E

SW 700 - SW 5070

S32NM5070(3A)99-11

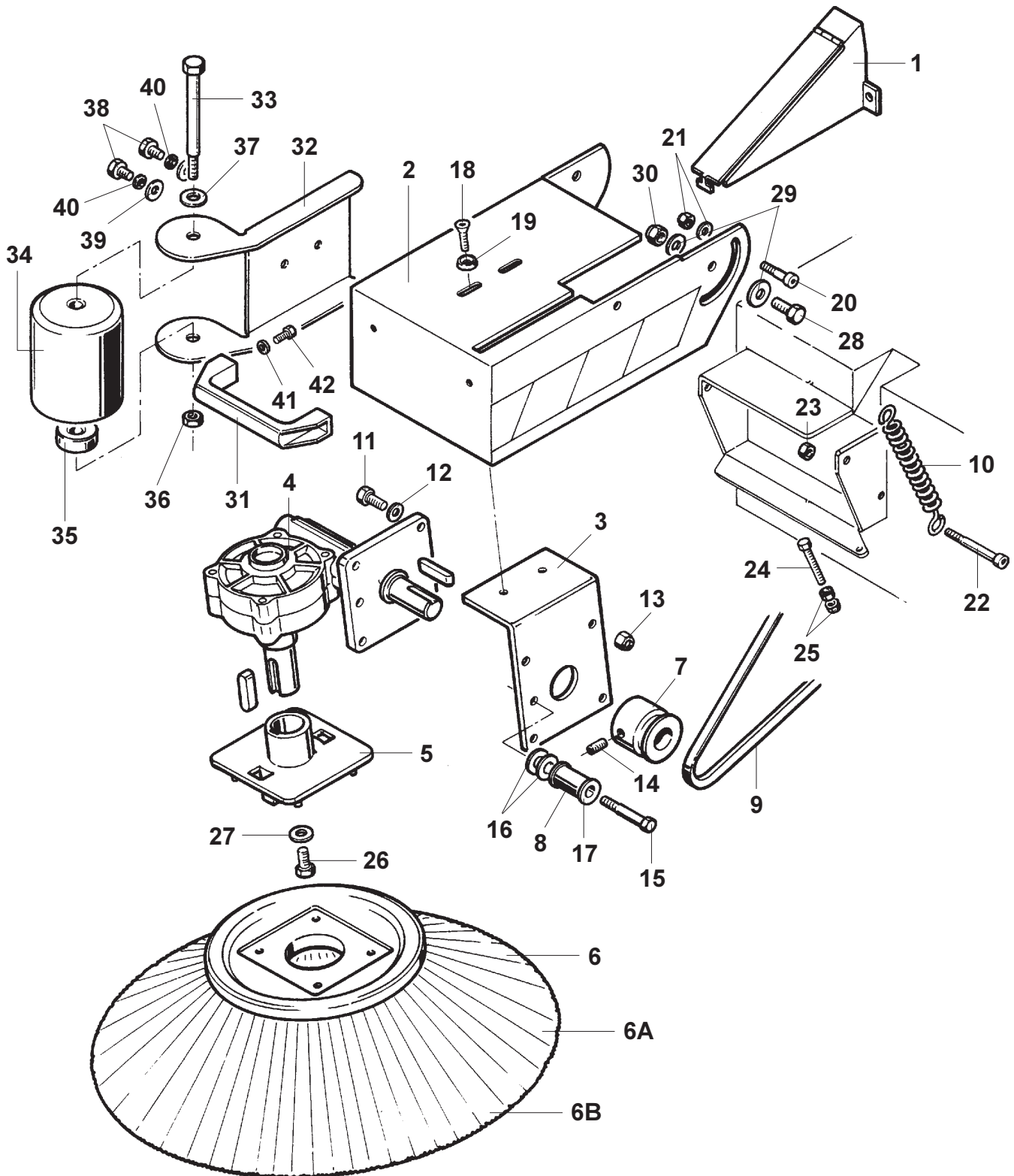

TAV. E / DRAW. E / VUE E / ZEICHN. E

POSIZ. ITEM POS. EINSAT.	CODICE CODE CODE NUMMER	CODICE INTERNO INTERNAL CODE CODE INTERIEUR INTERNE NUMMER	DESCRIZIONE DESCRIPTION DESCRIPTION BEZEICHNUNG	SW 700 - SW 5070 S32NM5070(3)99-09		
				B	P	O
41	145 9227 000	V02.004	RONDELLA / WASHER / RONDELLE / BEILAGSCHEIBE			2
42	145 9128 000	V09.004	VITE / SCREW / VIS / SCHRAUBE			2

TAV. F / DRAW. F / VUE F / ZEICHN. F

SW 700 - SW 5070

S32NM5070(3A)99-11

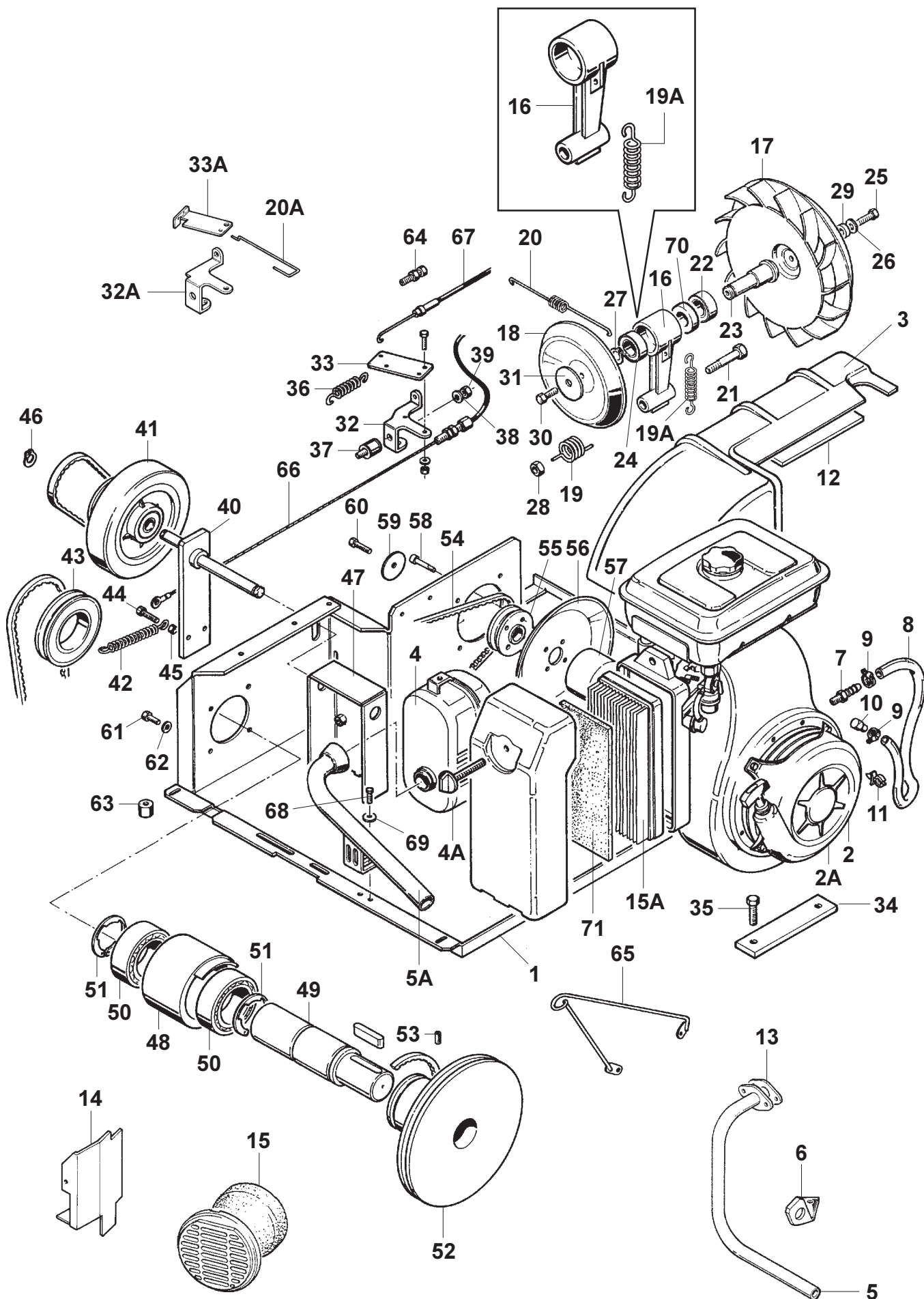

TAV. F / DRAW. F / VUE F / ZEICHN. F

POSIZ. ITEM POS. EINSAT.	CODICE CODE CODE NUMMER	CODICE INTERNO INTERNAL CODE CODE INTERIEUR INTERNE NUMMER	DESCRIZIONE DESCRIPTION DESCRIPTION BEZEICHNUNG	SW 700 - SW 5070 S32NM5070(3A)99-11		
				B	P	O
1	145 1919 000	-	PIASTRA / PLATE / PLAQUE / PLATTE		1	
2	145 1282 000	A01.02010	MOTORE / MOTOR / MOTEUR / MOTOR		1	
2A	145 5886 000	-	MOTORE / MOTOR / MOTEUR / MOTOR		1	
3	145 4651 000	-	PROTEZIONE / GUARD / PROTECTION / SCHUTZ		1	
4	145 1650 000	A04.13960	MARMITTA / SILENCER / MARMITE / SCHALLDAMPFER		1	
4A	145 5884 000	-	MARMITTA / SILENCER / MARMITE / SCHALLDÄMPFER		1	
5	145 4764 000	-	TUBO / TUBE / TUYAU / SCHLAUCH		1	
5A	145 5799 000	-	TUBO / TUBE / TUYAU / SCHLAUCH		1	
6	145 4756 000	-	ANTIVIBRANTE / VIBRATION DAMPING / SILENT BLOC / SCHWINGUNGSDAMP.		1	
7	145 4350 000	M03.20700	PORTAGOMMA / PIPE HOLDER / RACCORD / LEISTUNG HALTER		1	
8	145 5037 000	-	TUBO / TUBE / TUYAU / LEITUNGSSCHLAUCH		1	
9	145 8582 000	V20.02200	FASCETTA / CLAMP / COLLIER / PASSRING		2	
10	145 9220 000	M03.003	TAPPO / CAP / BOUCHON / PFROPFEN		1	
11	145 1281 000	V20.04400	FASCETTA / CLAMP / COLLIER / PASSRING		1	
12	145 4684 000	-	PANNELLO / PANEL / PANNEAU / PANEL		1	
13	145 4765 000	-	FLANGIA / FLANGE / FLASQUE / FLANSCH		1	
14	145 4686 000	-	PROTEZIONE / GUARD / PROTECTION / SCHUTZ		1	
15	145 5041 000	-	FILTRO ARIA / FILTER / FILTRE / FILTER		1	
15A	145 5885 000	-	FILTRO ARIA / FILTER / FILTRE / FILTER		1	
16	145 1922 000	-	SUPPORTO / SUPPORT / SUPPORT / HALTER		1	
17	145 9179 000	B03.001	VENTOLA / FAN / VENT / FLÜGEL		1	
18	145 4728 000	-	RUOTA / WHEEL / ROUE / RAD		1	
19	145 4743 000	-	MOLLA / SPRING / HOUSSE / FEDER (REPLACED BY 145 6086 000)		1	
19A	145 6086 000	-	MOLLA / SPRING / HOUSSE / FEDER (APPLICABLE FROM SERIAL NO. 93101957)		1	
20	145 4819 000	-	TIRANTE / TENSION ROD / TIRANT / ZUGSTANGE		1	
20A	145 5881 000	-	TIRANTE / TENSION ROD / TIRANT / ZUGSTANGE (APPLICABLE FROM SERIAL NO. 93101957)		1	
21	145 4729 000	-	VITE / SCREW / VIS / SCHRAUBE		1	
22	145 8415 000	E00.008	CUSCINETTO / BALL BEARING / ROULEMENT / LAGER		1	
23	145 4726 000	-	ALBERO / SHAFT / ARBRE / WELLE		1	
24	145 9271 000	E00.030	CUSCINETTO / BALL BEARING / ROULEMENT / LAGER		1	
25	145 9115 000	V02.012	VITE / SCREW / VIS / SCHRAUBE		1	
26	145 9126 000	V19.005	RONDELLA / WASHER / RONDELLE / BEILAGSCHEIBE		1	
27	145 9191 000	V14.008	SEEGER / RETAINING RING / CIRCLIPS / SICHERUNGSRING		1	
28	145 4518 000	V13.021	DADO / NUT / ECROU / MUTTER		1	
29	145 9180 000	E05.027	DISTANZIALE / SPACER / ENTRETOISE / ABSTANDSSTÜCK		1	
30	145 9115 000	V02.012	VITE / SCREW / VIS / SCHRAUBE		1	
31	145 9120 000	V09.005	RONDELLA / WASHER / RONDELLE / BEILAGSCHEIBE		1	
32	145 1921 000	-	STAFFA / HANGER / ETRIER / BUGEL		1	
32A	145 5880 000	-	STAFFA / HANGER / ETRIER / BÜGEL (APPLICABLE FROM SERIAL NO. 93101957)		1	
33	145 4754 000	-	PIATTINA FLAP ANT. / PLATE / PLAQUE / BAND		1	
33A	145 5879 000	-	PIATTINA FLAP ANT. / PLATE / PLAQUE / BAND (APPLICABLE FROM SERIAL NO. 93101957)		1	
34	145 1293 000	F03.68200	PIATTINA FLAP ANT. / PLATE / PLAQUE / BAND		2	
35	145 9217 000	V02.051	VITE / SCREW / VIS / SCHRAUBE		4	
36	145 5545 000	-	MOLLA / SPRING / HOUSSE / FEDER		1	

TAV. F / DRAW. F / VUE F / ZEICHN. F

SW 700 - SW 5070

S32NM5070(3A)99-11

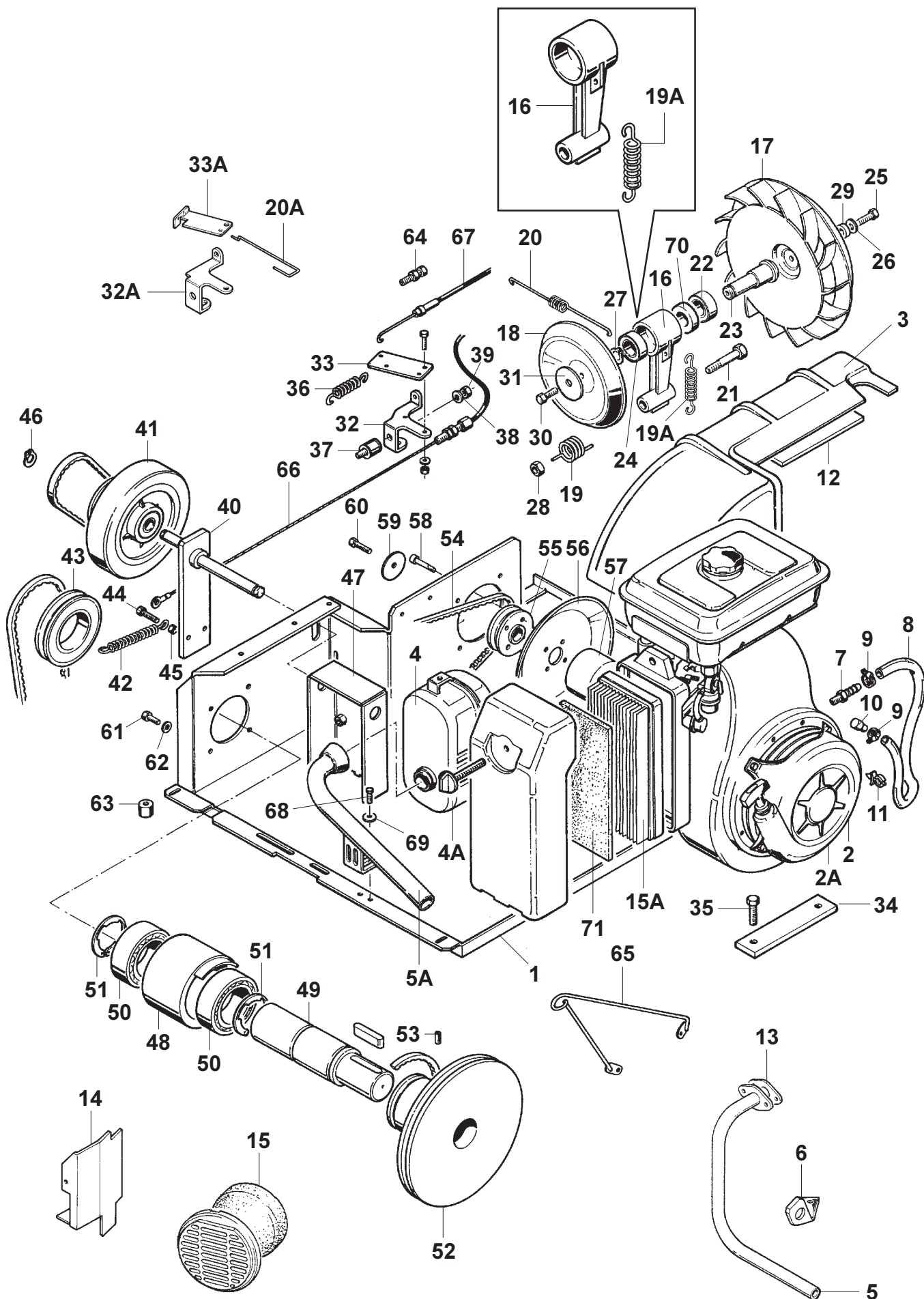

TAV. F / DRAW. F / VUE F / ZEICHN. F

POSIZ. ITEM POS. EINSAT.	CODICE CODE CODE NUMMER	CODICE INTERNO INTERNAL CODE CODE INTERIEUR INTERNE NUMMER	DESCRIZIONE DESCRIPTION DESCRIPTION BEZEICHNUNG	SW 700 - SW 5070 S32NM5070(3A)99-11		
				B	P	O
37	145 8054 000	L02.07900	ANTIVIBRANTE / VIBRATION DAMPING / SILENT BLOC / SCHWINGUNGSDÄMPFER		1	
38	145 9120 000	V09.005	RONDELLA / WASHER / RONDELLE / BEILAGSCHEIBE		2	
39	145 9123 000	V13.005	DADO / NUT / ECROU / MUTTER		2	
40	145 4730 000	-	LEVA / LEVER / LEVIER / HEBEL		1	
41	145 6037 000	-	RUOTA FRIZIONE / FRICTION WHEEL / ROUE DE FRICT. / KUPPLUNGSRAD		1	
42	145 0274 000	E04.09490	MOLLA / SPRING / HOUSSE / FEDER		1	
43	145 4721 000	-	PULEGGIA / PULLEY / POULIE / SCHEIBE		1	
44	145 9261 000	V02.003	VITE / SCREW / VIS / SCHRAUBE		1	
45	145 9132 000	V13.019	DADO / NUT / ECROU / MUTTER		1	
46	145 4794 000	-	SEEGER / RETAINING RING / CIRCLIPS / SICHERUNGSRING		1	
47	145 1920 000	-	STAFFA / HANGER / ETRIER / BÜGEL		1	
48	145 4723 000	-	PORTACUSCINETTO / BALL BEARING HOLDER / ROULEMENT RACCORD / LAGERHALTER		1	
49	145 4720 000	-	CONTRALBERO / SHAFT / ARBRE / WELLE		1	
50	145 4795 000	-	CUSCINETTO / BALL BEARING / ROULEMENT / LAGER		2	
51	145 4796 000	-	SEEGER / RETAINING RING / CIRCLIPS / SICHERUNGSRING		2	
52	145 5472 000	-	PULEGGIA / PULLEY / POULIE / SCHEIBE		1	
53	145 4499 000	V08.00400	VITE / SCREW / VIS / SCHRAUBE		2	
54	145 9701 000	H00.028	CINGHIA / BELT / COURROIE / RIEMEN		1	
55	145 5471 000	-	PULEGGIA / PULLEY / POULIE / SCHEIBE		1	
56	145 4724 000	-	DISCO / PAD / DISQUE / DISK		1	
57	145 4733 000	-	MOZZO / HUB / MOYEU / NABE		1	
58	145 9253 000	V04.01300	VITE / SCREW / VIS / SCHRAUBE		4	
59	145 9213 000	V09.020	RONDELLA / WASHER / RONDELLE / BEILAGSCHEIBE		1	
60	145 5064 000	V02.12870	VITE / SCREW / VIS / SCHRAUBE		1	
61	145 9261 000	V02.003	VITE / SCREW / VIS / SCHRAUBE		4	
62	145 9233 000	V19.004	RONDELLA / WASHER / RONDELLE / BEILAGSCHEIBE		4	
63	145 8054 000	L02.07900	ANTIVIBRANTE / VIBRATION DAMPING / SILENT BLOC / SCHWINGUNGSDÄMPFER		3	
64	145 1179 000	E08.06800	REGISTRO M6 x 30 / ADJUSTMENT SCREWS M6 x 30 / VIS DE REGULATION M6 x 30 / EINSTELLSCHRAUBE M6 x 30 (APPLICABLE FROM SERIAL NO. 93101957)		1	
65	145 6035 000	-	ASTA / ROD / TIGE / STAB		1	
66	145 5310 000	-	CAVO TRAZIONE / CABLE / CABLE / KABEL		1	
67	145 1280 000	E08.15230	CAVO ASPIRAZIONE / CABLE / CABLE / KABEL		1	
68	145 9227 000	V02.004	VITE / SCREW / VIS / SCHRAUBE		2	
69	145 9128 000	V09.004	RONDELLA / WASHER / RONDELLE / BEILAGSCHEIBE		2	
70	146 0029 00	E05.041	DISTANZIALE / SPACER / ENTRETOISE / ABSTANDSSTÜCK		1	
71	145 5971 000	-	PROTEZIONE FILTRO / GUARD / PROTECTION / SCHUTZ		1	

TAV. G / DRAW. G / VUE G / ZEICHN. G

SW 700 - SW 5070

S32NM5070(3A)99-11

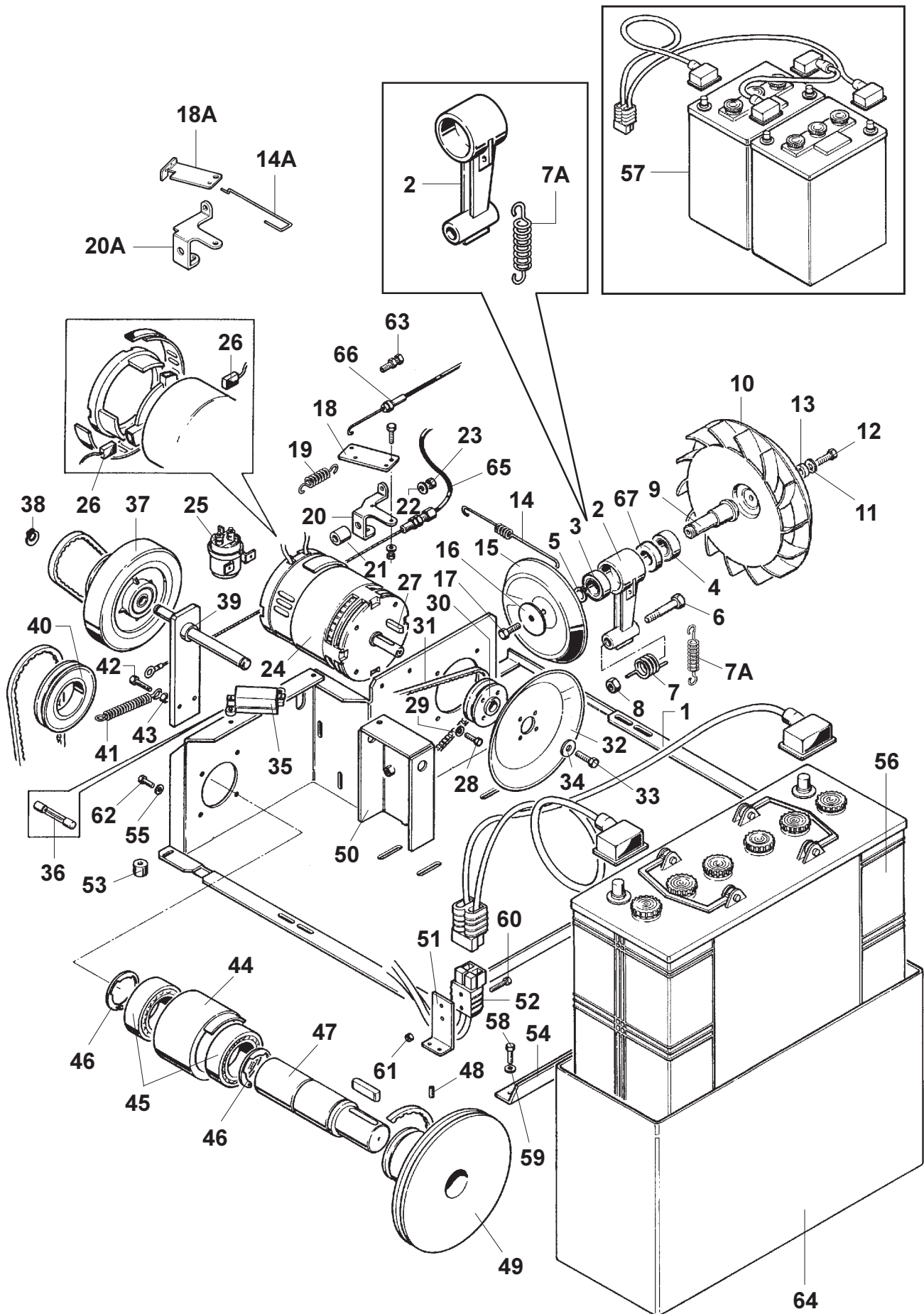

TAV. G / DRAW. G / VUE G / ZEICHN. G

POSIZ. ITEM POS. EINSAT.	CODICE CODE CODE NUMMER	CODICE INTERNO INTERNAL CODE CODE INTERIEUR INTERNE NUMMER	DESCRIZIONE DESCRIPTION DESCRIPTION BEZEICHNUNG	SW 700 - SW 5070 S32NM5070(3A)99-11		
				B	P	O
1	145 1919 000	-	PIASTRA / PLATE / PLAQUE / PLATTE	1		
2	145 1922 000	-	SUPPORTO / SUPPORT / SUPPORT / HALTER	1		
3	145 9271 000	E00.030	CUSCINETTO / BALL BEARING / ROULEMENT / LAGER	1		
4	145 8415 000	E00.008	CUSCINETTO / BALL BEARING / ROULEMENT / LAGER	1		
5	145 9191 000	V14.008	SEEGER / RETAINING RING / CIRCLIPS / SICHERUNGSRING	1		
6	145 4729 000	-	VITE / SCREW / VIS / SCHRAUBE	1		
7	145 4743 000	-	MOLLA / SPRING / RESSORT / FEDER (REPLACED BY 145 6086 000)	1		
7A	145 6086 000	-	MOLLA / SPRING / RESSORT / FEDER (APPLICABLE FROM SERIAL NO. 93101957)	1		
8	145 4518 000	V13.021	DADO / NUT / ECROU / MUTTER	1		
9	145 4726 000	-	ALBERO / SHAFT / ARBRE / WELLE	1		
10	145 9179 000	B03.001	VENTOLA / FAN / VENT / FLÜGEL	1		
11	145 9126 000	V19.005	RONDELLA / WASHER / RONDELLE / BEILAGSCHEIBE	1		
12	145 9115 000	V02.012	VITE / SCREW / VIS / SCHRAUBE	1		
13	145 9180 000	E05.027	DISTANZIALE / SPACER / ENTRETOISE / ABSTANDSSTÜCK	1		
14	145 4819 000	-	TIRANTE / TENSION ROD / TIRANT / ZUGSTANGE	1		
14A	145 5881 000	-	TIRANTE / TENSION ROD / TIRANT / ZUGSTANGE (APPLICABLE FROM SERIAL NO. 93101957)	1		
15	145 4728 000	-	RUOTA / WHEEL / ROUE / RAD	1		
16	145 9120 000	V09.005	RONDELLA / WASHER / RONDELLE / BEILAGSCHEIBE	1		
17	145 9115 000	V02.012	VITE / SCREW / VIS / SCHRAUBE	1		
18	145 4754 000	-	PIATTINA FLAP ANT. / PLATE / PLAQUE / BAND	1		
18A	145 5879 000	-	PIATTINA FLAP ANT. / PLATE / PLAQUE / BAND (APPLICABLE FROM SERIAL NO. 93101957)	1		
19	145 5545 000	-	MOLLA / SPRING / RESSORT / FEDER	1		
20	145 1921 000	-	STAFFA / HANGER / ETRIER / BUGEL	1		
20A	145 5880 000	-	STAFFA / HANGER / ETRIER / BÜGEL (APPLICABLE FROM SERIAL NO. 93101957)	1		
21	145 8054 000	L02.07900	ANTIVIBRANTE / VIBRATION DAMPING / SILENT BLOC / SCHWINGUNGSDÄMPFER	1		
22	145 9120 000	V09.005	RONDELLA / WASHER / RONDELLE / BEILAGSCHEIBE	2		
23	145 9123 000	V13.005	DADO / NUT / ECROU / MUTTER	2		
24	145 4798 000	-	MOTORE ELETTRICO / ELECTRIC MOTOR / MOTEUR ELECTR. / ELEKTROMOTOR	1		
25	145 9434 000	G02.004	TELERUTTORE / ELECTROMAGN. SWITCH / TELERUPTEUR / SCHALTER	1		
26	145 5042 000	-	SPAZZOLA / BRUSH / BROSSSE / BÜRSTE	4		
27	145 9774 000	V17.041	CHIAVETTA / KEY / CLAVETTE / KEILNUT	1		
28	145 9261 000	V02.003	VITE / SCREW / VIS / SCHRAUBE	4		
29	145 9233 000	V19.004	RONDELLA / WASHER / RONDELLE / BEILAGSCHEIBE	4		
30	145 5473 000	-	PULEGGIA / PULLEY / POULIE / SCHEIBE	1		
31	145 9701 000	H00.028	CINGHIA / BELT / COURROIE / RIEMEN	1		
32	145 4724 000	-	DISCO / PAD / DISQUE / DISK	1		
33	145 9261 000	V02.003	VITE / SCREW / VIS / SCHRAUBE	1		
34	145 9229 000	V09.022	RONDELLA / WASHER / RONDELLE / BEILAGSCHEIBE	1		
35	145 8046 000	G11.05000	PORTAFUSIBILE / FUSE HOLDER / PORTEFUSIBLE / SICHERUNGSTRÄGER	1		
36	145 8047 000	G11.04500	FUSIBILE / FUSE / FUSIBLE / SICHERUNG	1		
37	145 6037 000	-	RUOTA / WHEEL / ROUE / RAD	1		
38	145 4794 000	-	SEEGER / RETAINING RING / CIRCLIPS / SICHERUNGSRING	1		
39	145 4730 000	-	LEVA / LEVER / LEVIER / HEBEL	1		
40	145 4721 000	-	PULEGGIA / PULLEY / POULIE / SCHEIBE	1		

TAV. G / DRAW. G / VUE G / ZEICHN. G

SW 700 - SW 5070

S32NM5070(3A)99-11

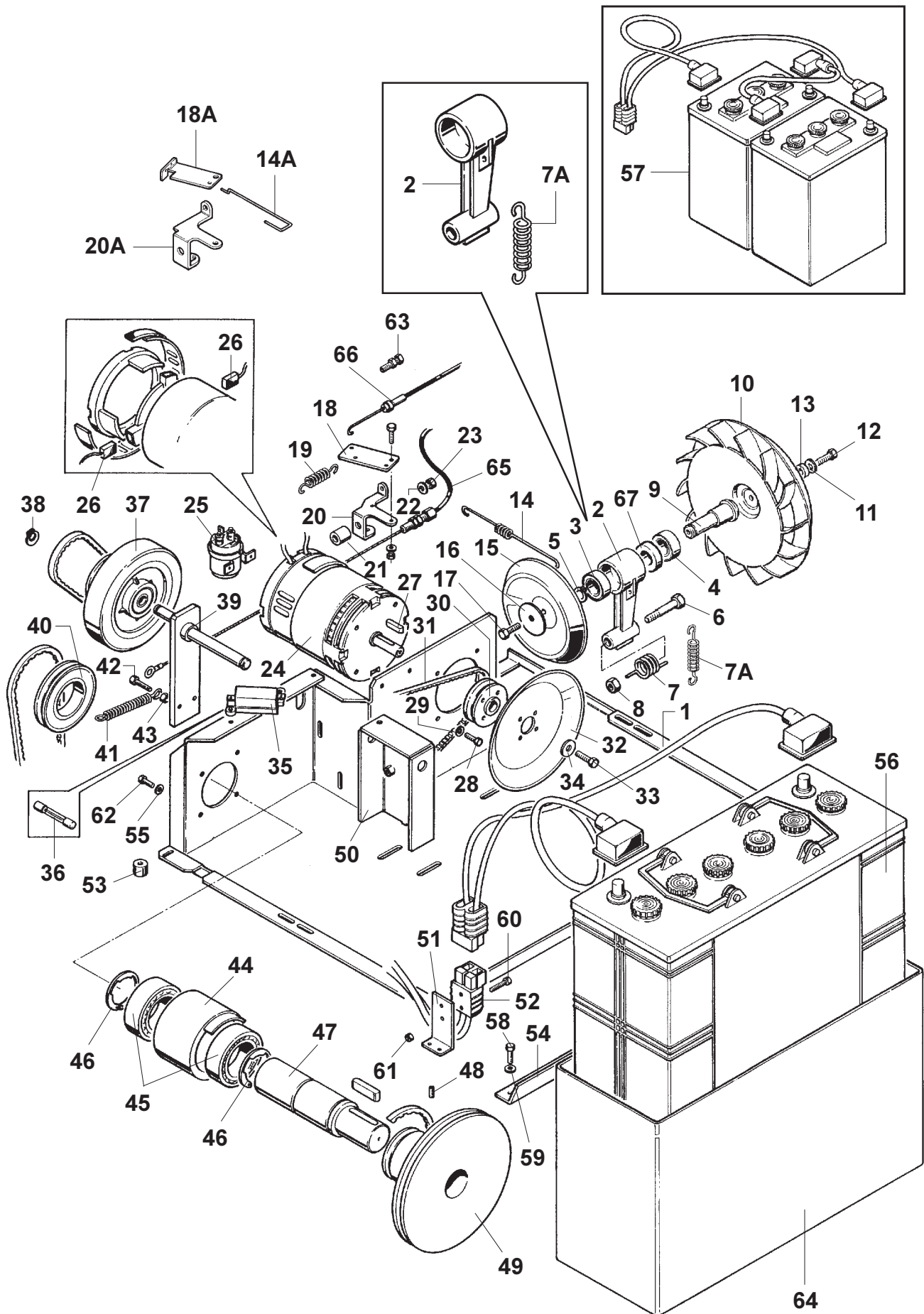

TAV. G / DRAW. G / VUE G / ZEICHN. G

POSIZ. ITEM POS. EINSAT.	CODICE CODE CODE NUMMER	CODICE INTERNO INTERNAL CODE CODE INTERIEUR INTERNE NUMMER	DESCRIZIONE DESCRIPTION DESCRIPTION BEZEICHNUNG	SW 700 - SW 5070		
				S32NM5070(3A)99-11		
				B	P	O
41	145 0274 000	E04.09490	MOLLA / SPRING / RESSORT / FEDER	1		
42	145 9261 000	V02.003	VITE / SCREW / VIS / SCHRAUBE	1		
43	145 9132 000	V13.019	DADO / NUT / ECROU / MUTTER	1		
44	145 4723 000	-	PORTACUSCINETTO / BALL BEARING HOLDER / ROULEMENT RACCORD / LAGERHALTER	1		
45	145 4795 000	-	CUSCINETTO / BALL BEARING / ROULEMENT / LAGER	2		
46	145 4796 000	-	SEEGER / RETAINING RING / CIRCLIPS / SICHERUNGSRING	2		
47	145 4720 000	-	ALBERO / SHAFT / ARBRE / WELLE	1		
48	145 4499 000	V08.00400	VITE / SCREW / VIS / SCHRAUBE	2		
49	145 5472 000	-	PULEGGIA / PULLEY / POULIE / SCHEIBE	1		
50	145 1920 000	-	STAFFA / HANGER / ETRIER / BÜGEL	1		
51	145 4755 000	-	STAFFA / HANGER / ETRIER / BÜGEL	1		
52	145 9417 000	G03.006	CONNETTORE / CONNECTOR / PRISE / KOPPLUNGSSTÜK	3		
53	145 8054 000	L02.07900	ANTIVIBRANTE / VIBRATION DAMPING / SILENT BLOC / SCHWINGUNGSDÄMPFER	3		
54	145 1923 000	-	STAFFA / HANGER / ETRIER / BÜGEL	1		
55	145 9233 000	V19.004	RONDELLA / WASHER / RONDELLE / BEILAGSCHEIBE	4		
56	145 0116 000	WOP.G3700	BATTERIA / BATTERY / BATTERIE / BATTERIE 12V / 140 Ah			1
57	145 0000 000	WOP.G0300	BATTERIA / BATTERY / BATTERIE / BATTERIE 6V / 240 Ah			2
58	145 9261 000	V02.003	VITE / SCREW / VIS / SCHRAUBE	2		
59	145 9128 000	V09.004	RONDELLA / WASHER / RONDELLE / BEILAGSCHEIBE	4		
60	145 4483 000	V02.09203	VITE / SCREW / VIS / SCHRAUBE	2		
61	145 9287 000	V13.018	DADO / NUT / ECROU / MUTTER	2		
62	145 9261 000	V02.003	VITE / SCREW / VIS / SCHRAUBE	4		
63	145 1179 000	E08.06800	REGISTRO M6 x 30 / ADJUSTMENT SCREZ M6 x 30 / VIS DE REGULATION M6 x 30 / EINSTELLSCHRAUBE M6 x 30 (APPLICABLE FROM SERIAL NO. 93101957)	1		
64	145 5252 000	-	CONTENITORE BATTERIE IN PLASTICA / PLASTIC BATTERY BOX / RECIPIENT EN PLASTIQUE POUR BATTERIES / BATTERIEKASTEN AUS KUNSTSTOFF			1
65	145 5310 000	-	CAVO TRAZIONE / CABLE / CABLE / KABEL	1		
66	145 1280 000	-	CAVO ASPIRAZIONE / CABLE / CABLE / KABEL	1		
67	146 0029 000	E05.041	DISTANZIALE / SPACER / ENTRETOISE / ABSTANDSSTÜCK	1		

TAV. H / DRAW. H / VUE H / ZEICHN. H

SW 700 - SW 5070

S32NM5070(3A)99-11

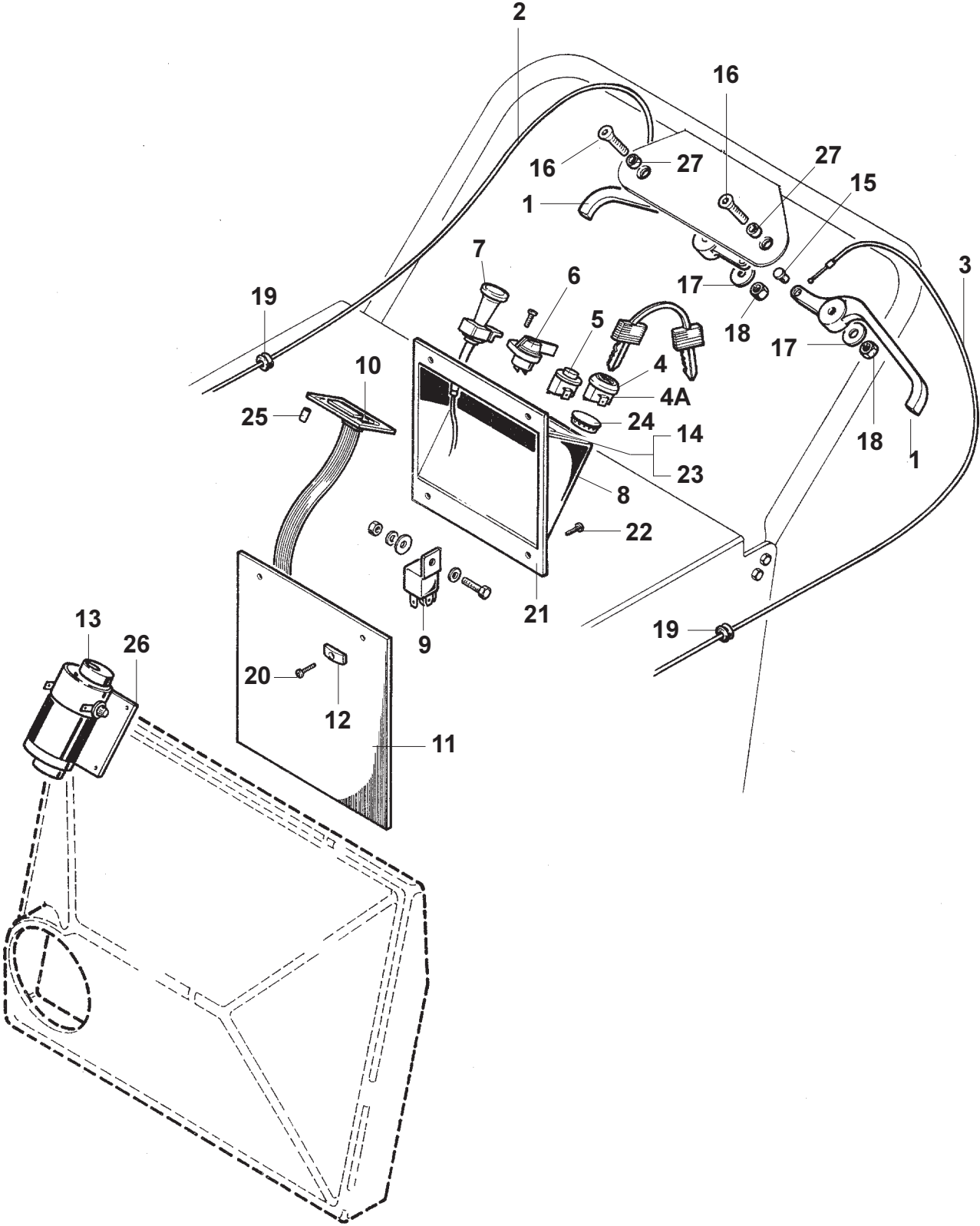

TAV. H / DRAW. H / VUE H / ZEICHN. H

POSIZ. ITEM POS. EINSAT.	CODICE CODE CODE NUMMER	CODICE INTERNO INTERNAL CODE CODE INTERIEUR INTERNE NUMMER	DESCRIZIONE DESCRIPTION DESCRIPTION BEZEICHNUNG	SW 700 - SW 5070 S32NM5070(3A)99-11		
				B	P	O
1	145 4745 000	-	LEVA / LEVER / LEVIER / HEBEL	2	2	
2	145 5310 000	-	CAVO TRAZIONE / CABLE / CABLE / KABEL	1	1	
3	145 4766 000	-	CAVO ALZAFLAP / CABLE / CABLE / KABEL	1	1	
4	145 0372 000	G05.11130	INTERRUTTORE / SWITCH / INTERRUPTEUR / SCHALTER	1		
4A	146 0006 00	-	INTERRUTTORE / SWITCH / INTERRUPTEUR / SCHALTER	1		
5	145 8885 000	G05.08200	PULSANTE / PUSH BUTTON / BOUTON POUSSOIR / KNOFF			1
6	145 0398 000	A04.13700	INTERRUTTORE / SWITCH / INTERRUPTEUR / SCHALTER		1	
7	145 1280 000	E08.15230	CAVO ASPIRAZIONE / CABLE / CABLE / KABEL	1	1	
8	145 4641 000	-	PLANCIA / PANEL / PLANCHE / PANEEL		1	
9	145 9377 000	G02.00700	RELE' / RELAY / RELAIS / RELAIS	1		
10	145 4803 000	-	SCHEDA / CARD / PLATINE / KARTE	1		
11	145 5017 000	-	GOMMA / PIPE / RACCORD / GUMMI	1	1	
12	145 1180 000	H01.26340	PIATTINA FLAP ANT. / PLATE / PLAQUE / BAND	2	2	
13	145 8105 000	A00.00801	SCUOTIFILTRO / FILTERSHAKER / DECOLMATAGE DU FILTRE / FILTERRÜTLER			1
14	145 4752 000	-	SERIGRAFIA PLANCIA / PANEL / PLANCHE / PANEEL		1	
15	145 9279 000	E08.007	PERNO / PIN / AXE / STIFT	2	2	
16	145 0559 000	V06.00220	VITE / SCREW / VIS / SCHRAUBE	2	2	
17	145 9229 000	V09.022	RONDELLA / WASHER / RONDELLE / BEILAGSCHEIBE	2	2	
18	145 9132 000	V13.019	DADO / NUT / ECROU / MUTTER	2	2	
19	145 9246 000	G07.003	PASSACAVO / CABLE GUIDE / GUIDE CABLE / KABELFÜHRUNG	2	2	
20	145 1145 000	V03.03710	VITE / SCREW / VIS / SCHRAUBE	4	4	
21	145 4642 000	-	PLANCIA / PANEL / PLANCHE / PANEEL	1		
22	145 4775 000	-	VITE / SCREW / VIS / SCHRAUBE	4	4	
23	145 4751 000	-	SERIGRAFIA PLANCIA / PANEL / PLANCHE / PANEEL	1		
24	145 4270 000	L02.05900	TAPPO / CAP / BOICHON / PFROPFEN	1		
25	145 0516 000	L02.13700	DISTANZIALE / SPACER / ENTRETOISE / ABSTANDSSTÜCK	3		
26	145 4818 000	-	PIASTRA / PLATE / PLAQUE / PLATTE			1
27	145 4744 000	-	DISTANZIALE / SPACER / ENTRETOISE / ABSTANDSSTÜCK	4	4	

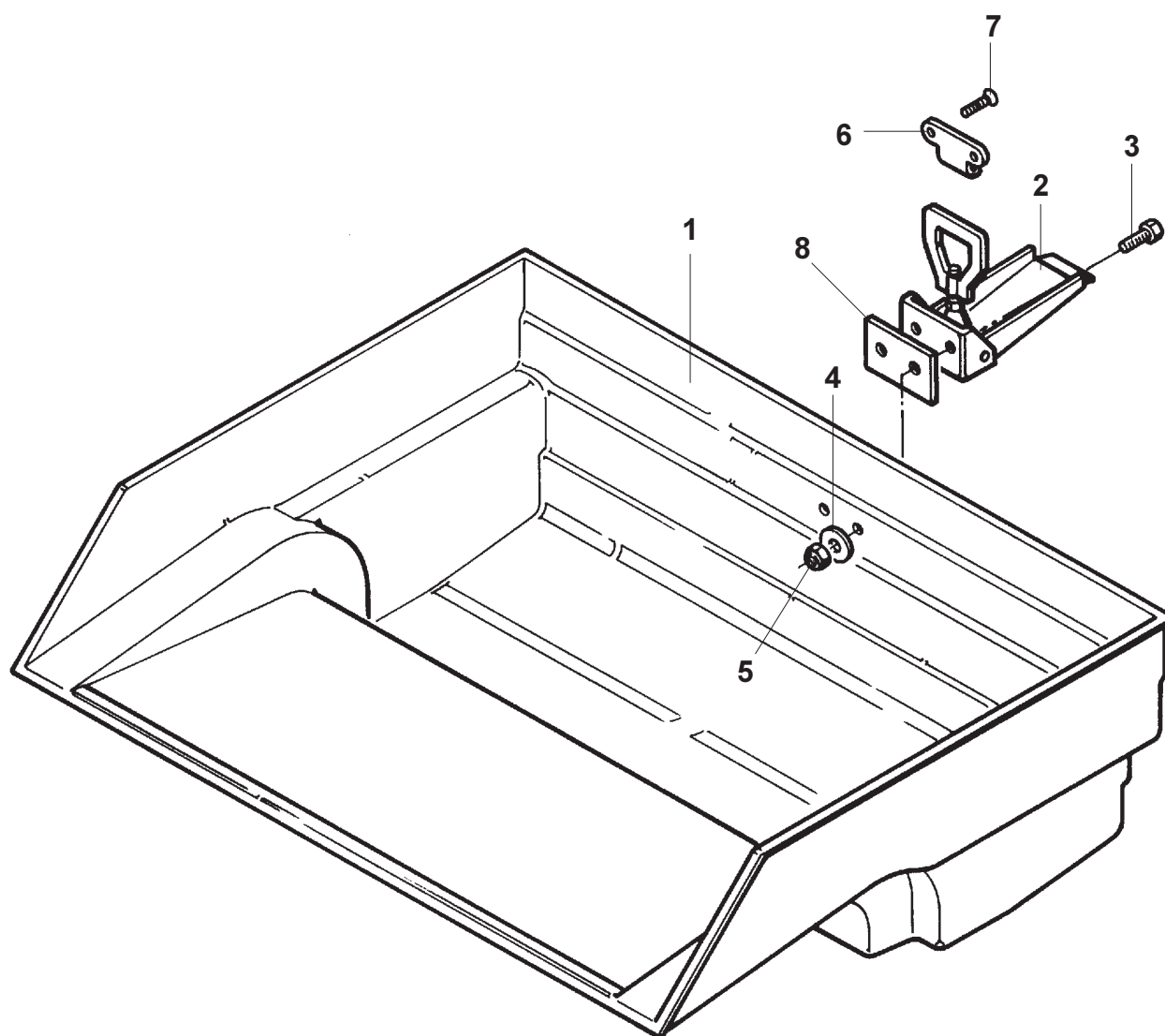

TAV. I / DRAW. I / VUE I / ZEICHN. I

POSIZ. ITEM POS. EINSAT.	CODICE CODE CODE NUMMER	CODICE INTERNO INTERNAL CODE CODE INTERIEUR INTERNE NUMMER	DESCRIZIONE DESCRIPTION DESCRIPTION BEZEICHNUNG	SW 700 - SW 5070 S32NM5070(3)99-09		
				B	P	O
1	145 4649 000	-	CASSETTO / CONTAINER / DECHETS / BEHÄLTER	1	1	
2	145 9136 000	L02.028	GANCIO / HOOK / CROCHET / HAKEN	1	1	
3	145 4481 000	V02.07400	VITE / SCREW / VIS / SCHRAUBE	2	2	
4	145 9254 000	V19.003	RONDELLA / WASHER / RONDELLE / BEILAGSCHEIBE	2	2	
5	145 9134 000	V13.003	DADO / NUT / ECROU / MUTTER	2	2	
6	145 9148 000	F02.414	PIASTRINA / PLATE / PLAQUE / PLATTE	1	1	
7	145 5065 000	V03.019	VITE / SCREW / VIS / SCHRAUBE	2	2	
8	145 5246 000	-	PIASTRINA DI SPESSORE / SPACER / PLAQUE DE EPAISSEUR / DICKEPLATTE	1	1	

Nilfisk-Advance Italia S.p.A.
Località Novella Terza
26862 Guardamiglio (LO) Italia
Tel. + 39 0377 451124
Fax + 39 0377 51443

S32NM5070(3A)99-11

Progetto Grafico **PROMIND** Brescello Italia