

SALTIX 10, SALTIX 10 C, ALTO 101D

Model:
SALTIX 10
SALTIX 10 C



Stückliste Deutsch

10-09-2014

Nilfisk
ALTO
works for you

www.nilfisk-alto.com

Inhalt

SALTIX 10, SALTIX 10 C, ALTO 101D

Summary ALTO 101D, SALTIX 10 C	3
Summary SALTIX 10	5
Zubehör	7
EMPFOHLENE ERSATZTEILE	9

Summary ALTO 101D, SALTIX 10 C

SALTIX 10, SALTIX 10 C, ALTO 101D

10-09-2014

ET-Liste-Nr.
SALTIX1002

3

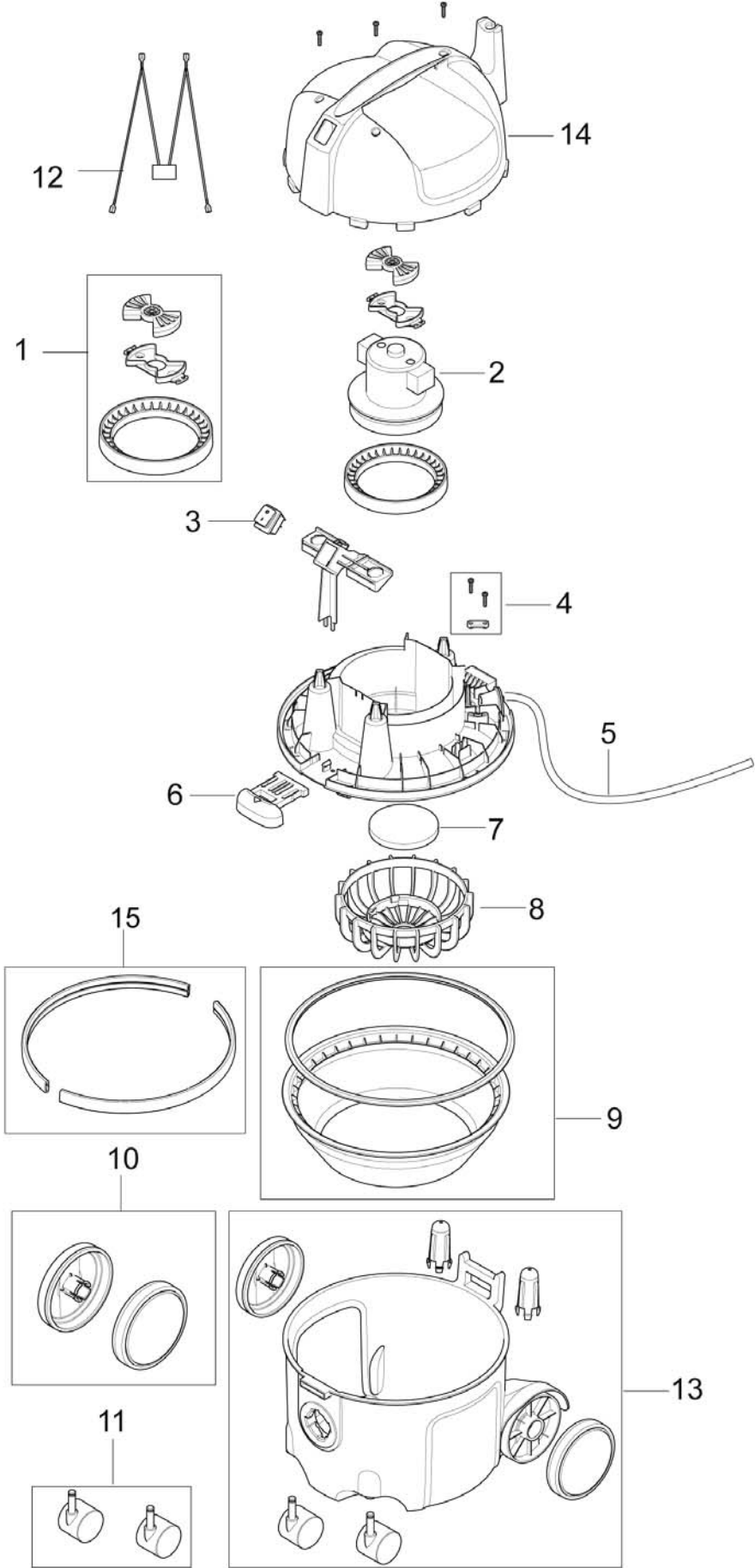

Summary ALTO 101D, SALTIX 10 C

SALTIX 10, SALTIX 10 C, ALTO 101D

10-09-2014

ET-Liste-Nr.
SAL I IX100Z

4

Pos	Artikelnr.	Me	Beschreibung	
0		1	Box VC 300	
0	147 1436 000	1	Box GD 111	
1	147 0660 500	1	Motorhalterung	
2	107407518	1	FAN UNIT 220-240V 900W CN KIT	CN
2	147 1428 500	1	Motor 230-240V 900W TCO	EU
3	140 9537 500	1	Wippschalter 0-1 2polig "MAXXI 3/7/DUO	
4	140 6560 500	1	ANTI STRAIN CLIP	
5	140 6800 650	1	Cord Set 10m	EU
5	147 0504 540	1	CORD SET 10.5M CHINA	CN
6	147 1409 500	1	Verschlussriegel	Grey
7	147 0670 500	1	FILTER MOTOR KIT GD910	
8	147 0669 500	1	BASKET SACK FILTER GD910	
9	147 1432 500	1	Filtersack hälter + Motor)	Accessory
10	140 8458 500	1	Hinterrad Kit f. UZ 932/934	
11	140 6422 500	1	Lenkrolle ø50 Set-2 "MAXXI 3 f. UZ 934	
12	107407519	1	SUPPRESSOR UNIT CCC L350 KIT	CN
12	140 7620 530	1	Entstörfilter Set"MAXXI 7" *EU/GB/AU/NZ	
13	107410008	1	CONTAINER SALTIX 10	
14	107410002	1	COVER TOP SALTIX 10 KIT	
15	107410399	1	BUMPER LIGHT GREY SET	

Summary SALTIX 10

SALTIX 10, SALTIX 10 C, ALTO 101D

10-09-2014

ET-Liste-Nr.
SALTIX1004

5

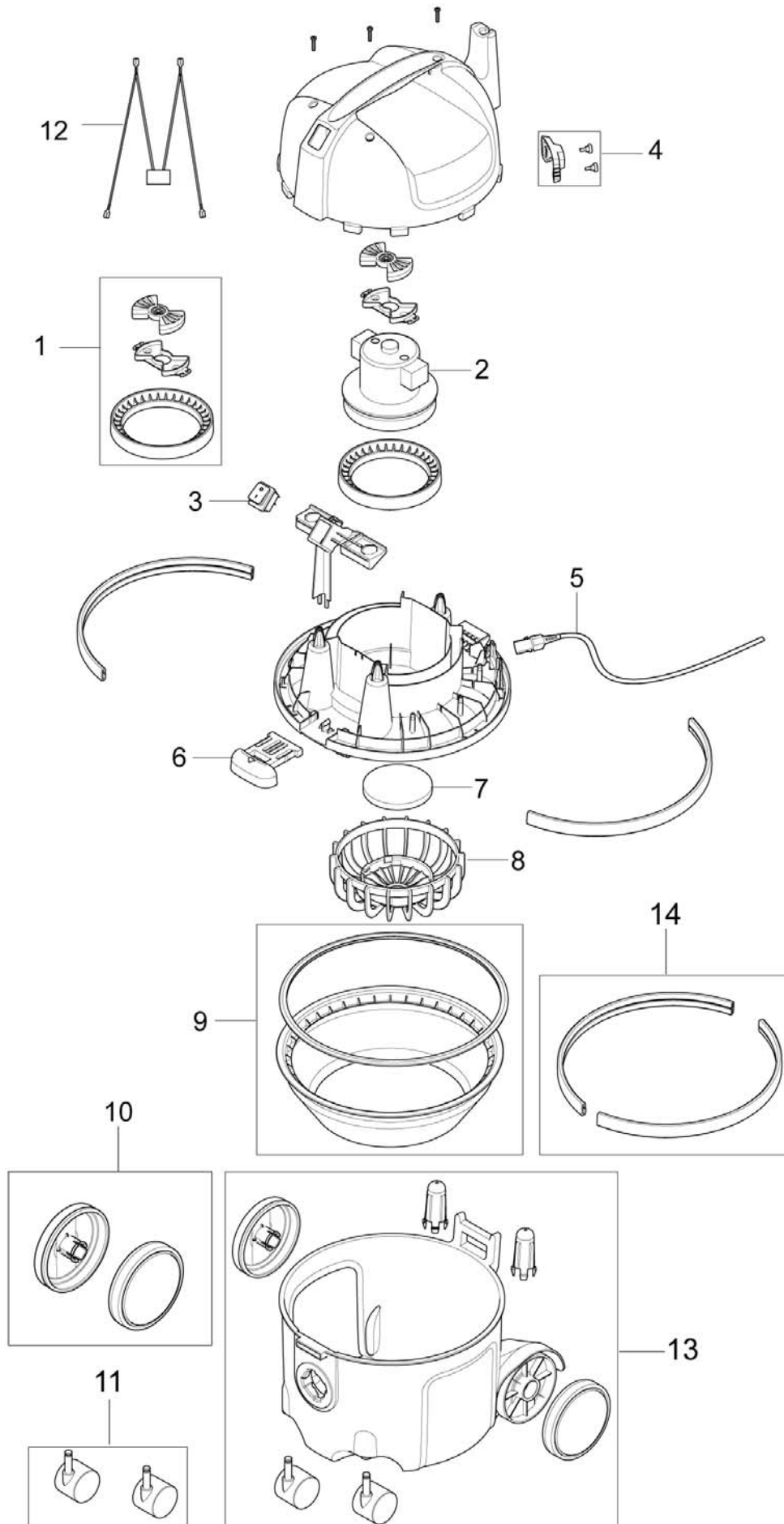

Summary SALTIX 10

SALTIX 10, SALTIX 10 C, ALTO 101D

10-09-2014

ET-Liste-Nr.
SAL I IX1004

6

Pos	Artikelnr.	Me	Beschreibung
0		1	Box VC 300
0	107403715	1	Box Kit Saltix 10
0	147 1436 000	1	Box GD 111
1	147 0660 500	1	Motorhalterung
2	107402675	1	Motoreinsatz 1200W
3	140 9537 500	1	Wippschalter 0-1 2polig "MAXXI 3/7/DUO
4	107402674	1	CORD LOCK KIT
5	107402676	1	Netzkabel abnehmbar 10 m
5	107402901	1	Netzkabel 15m, abnehmbar
6	147 1409 500	1	Verschlussriegel Grey
7	147 0670 500	1	FILTER MOTOR KIT GD910
8	147 0669 500	1	BASKET SACK FILTER GD910
9	147 1432 500	1	Filtersack hälter + Motor) Accessory
10	140 8458 500	1	Hinterrad Kit f. UZ 932/934
11	140 6422 500	1	Lenkrolle ø50 Set-2 "MAXXI 3 f. UZ 934
12	140 7620 530	1	Entstörfilter Set"MAXXI 7" *EU/GB/AU/NZ
13	107410008	1	CONTAINER SALTIX 10
14	107410399	1	BUMPER LIGHT GREY SET

Zubehör

SALTIX 10, SALTIX 10 C, ALTO 101D

10-09-2014

ET-Liste-Nr.
SALTIX1005

7

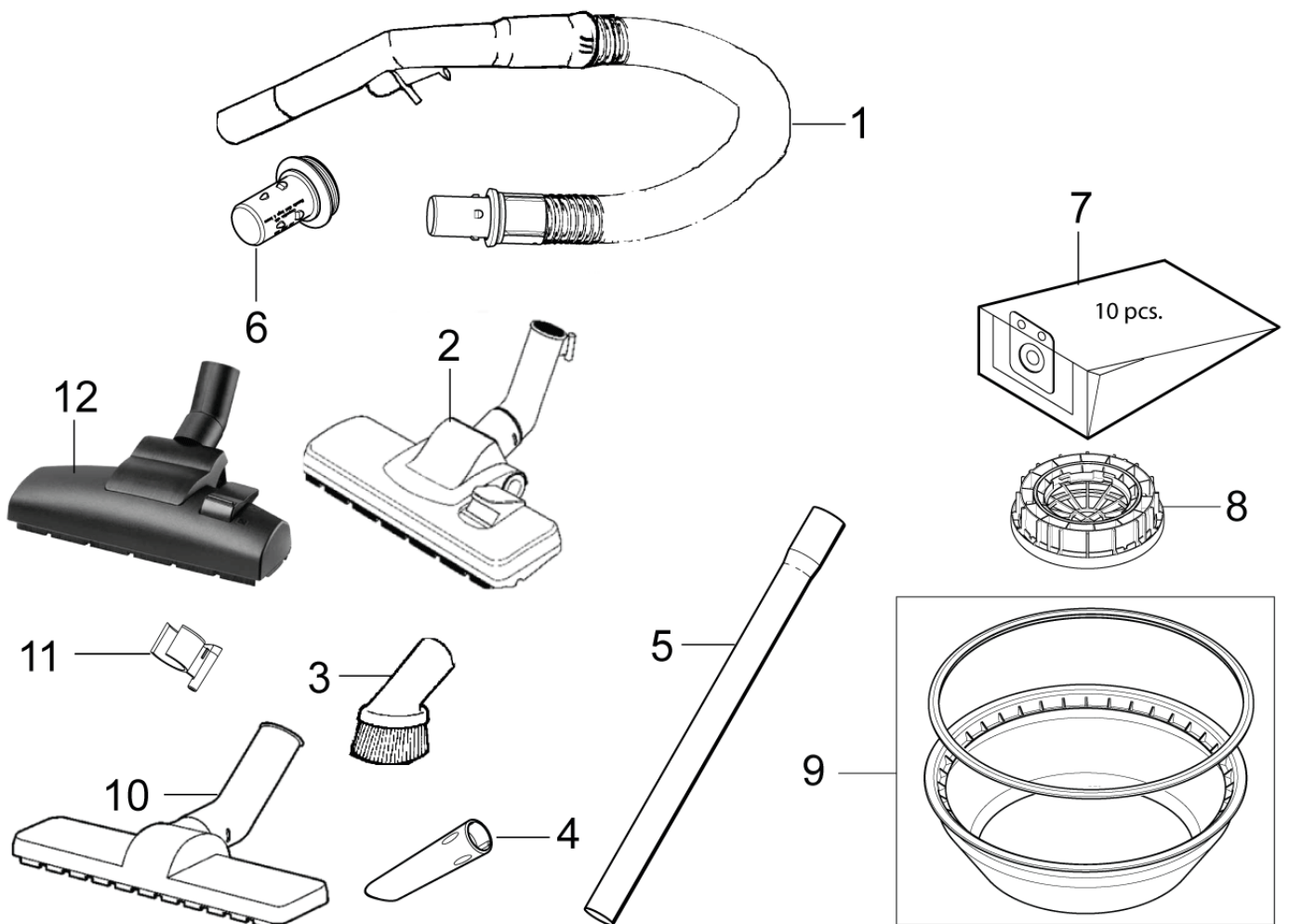

Zubehör

SALTIX 10, SALTIX 10 C, ALTO 101D

10-09-2014

ET-Liste-Nr.
SAL I IX1005

8

Pos	Artikelnr.	Me	Beschreibung	
0	107403715	1	Box Kit Saltix 10	SALTIX 10, ALTO 101D 10 PCS
1	147 0765 500	1	HOSE CPL BLACK 2m kpl. f. GD	
2	107403122	1	COMBI NOZZLE D252 KIT	
3	140 8244 500	1	BRUSH NOZZLE KIT	
4	147 0146 500	1	CREVICE NOZZLE D32 L153 B	
5	011 6431 500	2	EXTENSION TUBE, ALUMINIUM 32mm/1x500mm	
5	140 8246 040	2	HandrohrStahl 32x500 mm GD320/GWD335	
6	107401199	1	20 PCS NUMATIC ADAPTER	
7	140 8618 000	1	Filtersack 10 L, VPE 10 f. GD1010/2000/Saltix3	
8	107402902	1	HEPA FILTER BOXED	ONLY SALTIX 10
9	147 1432 500	1	Filtersack hälter + Motor)	
10	140 6700 540	1	Hartbodendüse ¥32mit Clip 30 cm	
11	147 0585 500	1	PARKING CLIP SVART	
12	107411677	1	COMBI NOZZLE RD277 KIT	

EMPFOHLENE ERSATZTEILE

SALTIX 10, SALTIX 10 C, ALTO 101D

10-09-2014

ET-Liste-Nr.
SALTIX1008

9

Keine Zeichnung zur ET-Liste

EMPFOHLENE ERSATZTEILE

SALTIX 10, SALTIX 10 C, ALTO 101D

10-09-2014

ET-Liste-Nr.
SAL I IX1008

10

Pos	Artikelnr.	Me	Beschreibung	
0	107402674	1	CORD LOCK KIT	SALTIX 10
0	107402675	1	Motoreinsatz 1200W	SALTIX 10
0	107402676	1	Netzkabel abnehmbar 10 m	SALTIX 10
0	140 6560 500	1	ANTI STRAIN CLIP	
0	140 6800 650	1	Cord Set 10m	101D
0	140 7620 530	1	Entstörf ilter Set*MAXXI 7" *EU/GB/AU/NZ	
0	140 8445 500	1	Lenkrollen KIT	
0	140 8458 500	1	Hinterrad Kit f. UZ 932/934	
0	140 9537 500	1	Wippschalter 0-1 2polig "MAXXI 3/7/DUO	
0	147 0504 540	1	CORD SET 10.5M CHINA	SALTIX 10C
0	147 0660 500	1	Motorhalterung	
0	147 0669 500	1	BASKET SACK FILTER GD910	
0	147 0670 500	1	FILTER MOTOR KIT GD910	
0	147 1428 500	1	Motor 230-240V 900W TCO	101D, SALTIX 10C
0	147 1432 500	1	Filtersack hälter + Motor)	
0	147 1436 000	1	Box GD 111	