

ATTIX 170

Model:
ATTIX 170



Part List US-English

08-02-2015

Nilfisk
ALTO
works for you

www.nilfisk-alto.com

Table of Contents

ATTIX 170

Lmh atex label	3
Frame 1	5
Frame 2	7
Frame 3	9
Container unit	11
Filter group	13
Manual shaker unit	15
Electrical shaker unit - 1	17
Electrical shaker unit - 2	19
Suction unit	21
Electric system	23
Electric board manual shaker	25
Electric board shaker unit	27

Lmh atex label

ATTIX 170

08-02-2015

Part List ID 330823

3

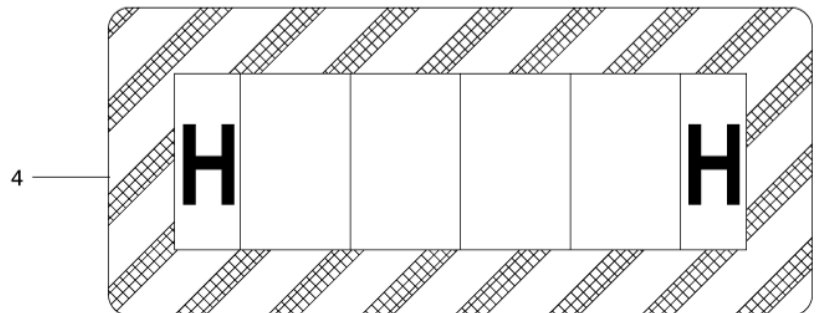
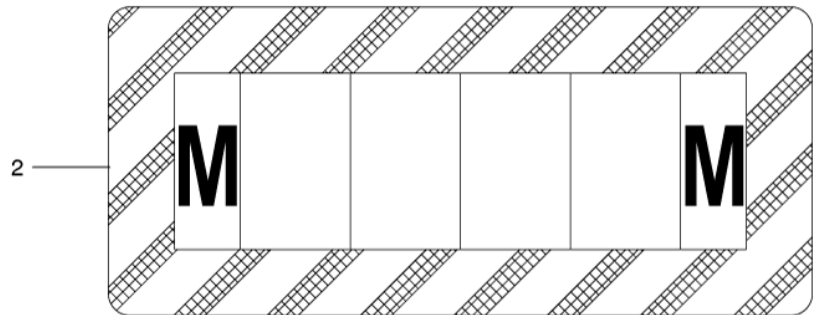
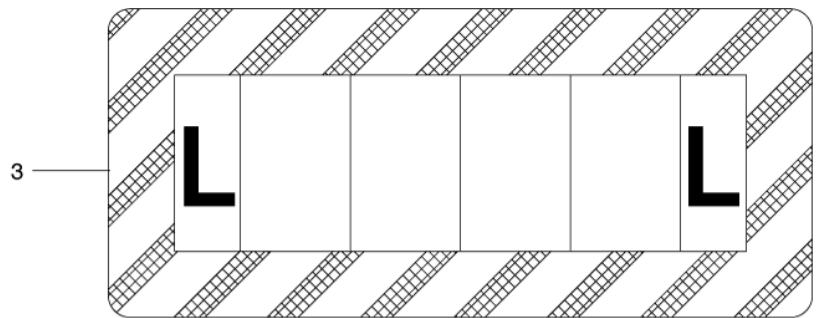
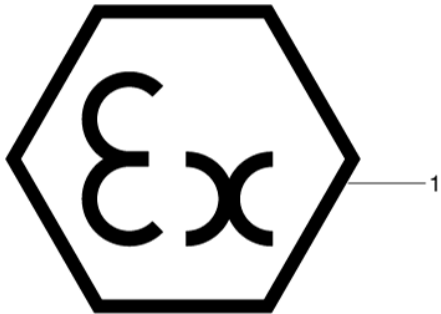

Lmh atex label

ATTIX 170

08-02-2015

Part List ID
330623

4

Pos	Part no.	Qty	Description
1		1	NOTE COMMENT
2		1	NOTE COMMENT
3	Z8 17550	1	LABEL CATEGORY L
4		1	NOTE COMMENT

Frame 1

ATTIX 170

08-02-2015

Part List ID
ATTIX17001

5

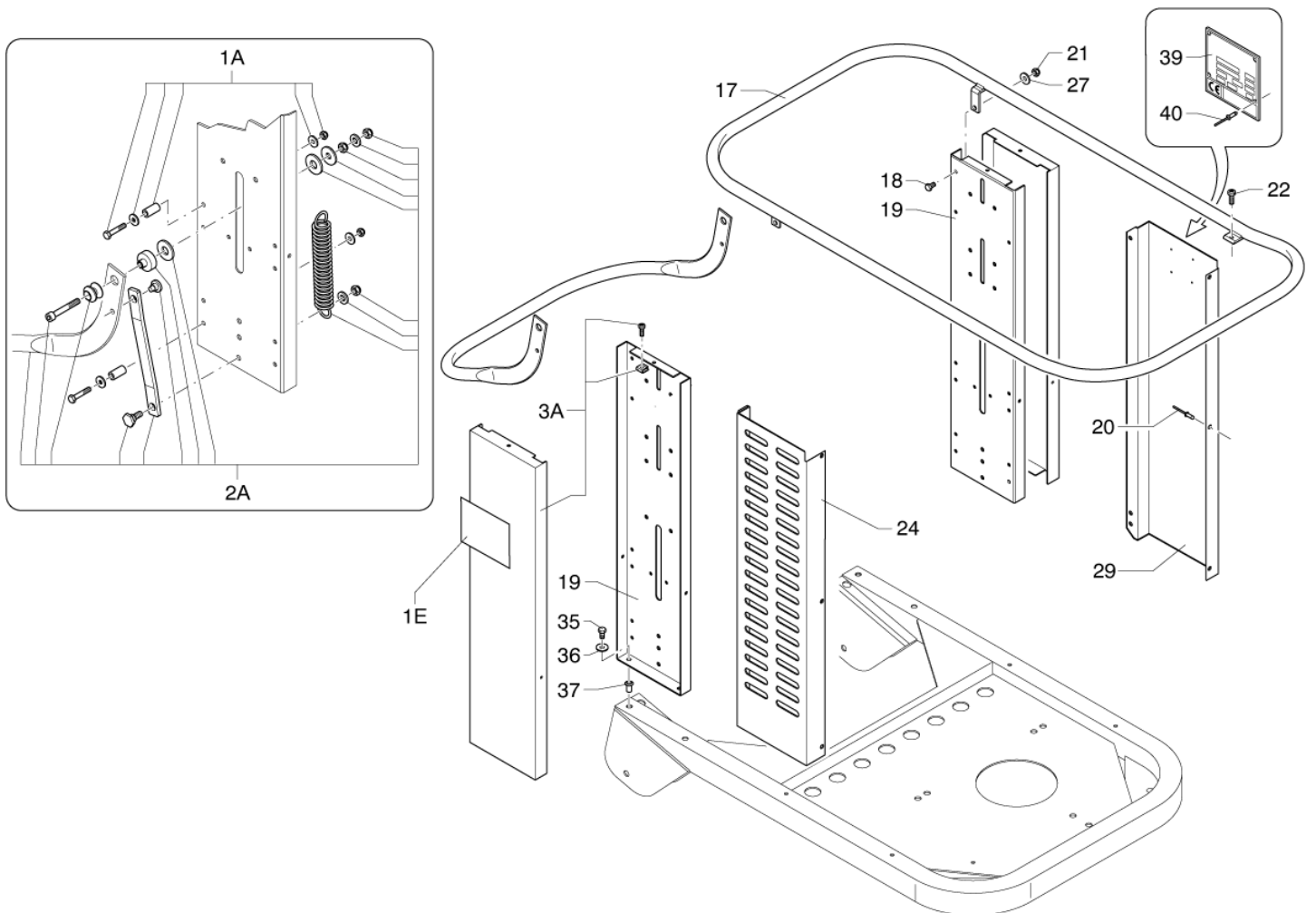

Frame 1

ATTIX 170

08-02-2015

Part List ID
A11IX17001

6

Pos	Part no.	Qty	Description
17	Z8 18987	1	HANDLE 3308-3508
18		2	NOTE COMMENT Screw M6x20 UNI 5739 DIN 933
19	Z8 18506	2	UPRIGHT M.137
1A	40000538	1	RELEASE LEVER BLOCKAGE KIT
20		11	NOTE COMMENT Rivet D.6,4x10 DIN 7337
21		2	NOTE COMMENT Nut M6 UNI 5588 DIN 934
22		2	NOTE COMMENT Screw M6x16 UNI 7687 DIN 7985
24	4083500163	1	LEFT CARTER 3308-3508 RAL 5005
27		2	NOTE COMMENT Washer D.6 UNI 6592 DIN 433
29	4083500162	1	RIGHT CARTER 3308-3508RAL5005
2A	40000539	1	RELEASE LEVER KIT
35		4	NOTE COMMENT Screw M8x16 UNI 5739 DIN 933
36		4	NOTE COMMENT Washer D.8 UNI 6592 DIN 433
37	Z8 38037	4	THREADED INSERT M8
39	ZS08AL17168	1	THREEPHASE PLATE NILFISK ALTO
3A	40000540	1	SIDE PANEL KIT
40		4	NOTE COMMENT Rivet D.2,9x7 UNI 7337

Frame 2

ATTIX 170

08-02-2015

Part List ID
ATTIX17003

7

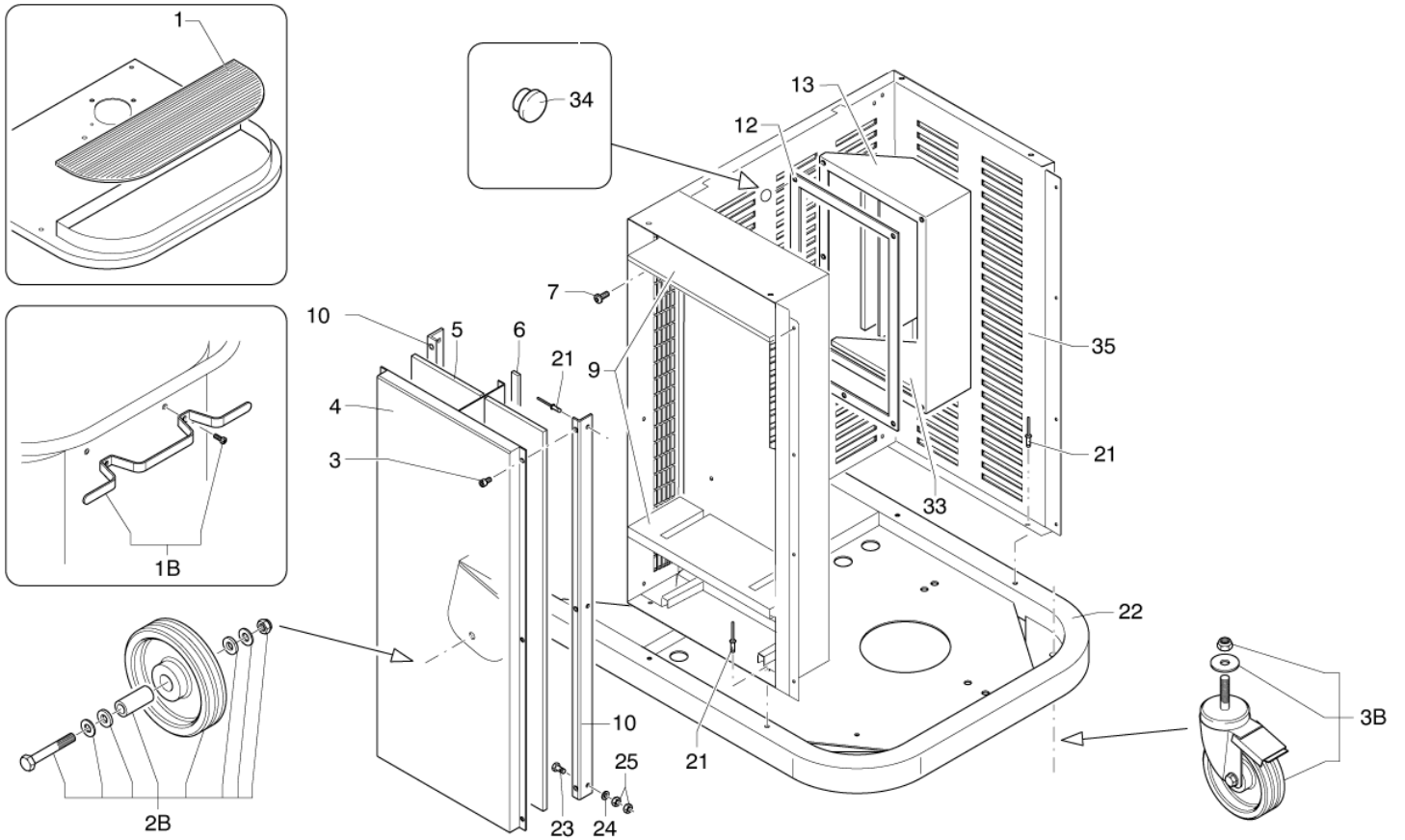

Frame 2

ATTIX 170

08-02-2015

Part List ID
A111X17003

8

Pos	Part no.	Qty	Description
1	Z8 17811	1	MAT FOR TANK 3308-3508
3		6	NOTE COMMENT Screw M6x16 UNI 5931 DIN 912
4	4081600455	1	LEFT PANEL 3308 RAL 5005
5	Z8 17644	1	SOUNDPROOF LEFT PANEL KIT
6	40000764	1	SEAL
7		4	NOTE COMMENT Screw M6x16 UNI 5931 DIN 912
9	Z8 17645	1	SOUNDPROOF LEFT SIDE KIT
10	Z8 18915	2	CORNER
12	Z8 17647	1	JUNCTION FOR CONVEYOR
13	4083500159	1	EXHAUST CONVEYOR RAL 5005
1B	40000544	1	KIT CABLE HOLDER
21		6	NOTE COMMENT Rivet D.6,4x10 DIN 7337
22	Z8 36469	1	TROLLEY 3308.3508
23		1	NOTE COMMENT Screw M6x20 UNI 5739 DIN 933
24		1	NOTE COMMENT Washer D.6 UNI 6592 DIN 433
25		2	NOTE COMMENT Nut M6 UNI 5588 DIN 934
2B	40000542	1	KIT FIX ASTOR D200
33	Z8 17646	1	SOUNDPROOF CONVEYOR KIT
34	Z8 39934	1	PLUG BLIND D18.5 RUBBER
35	4083500161	1	CARTER 3308-3508 RAL 5005
3B	40000541	1	KIT REVOLV. CASTOR D150

Frame 3

ATTIX 170

08-02-2015

Part List ID
ATTIX17005

9

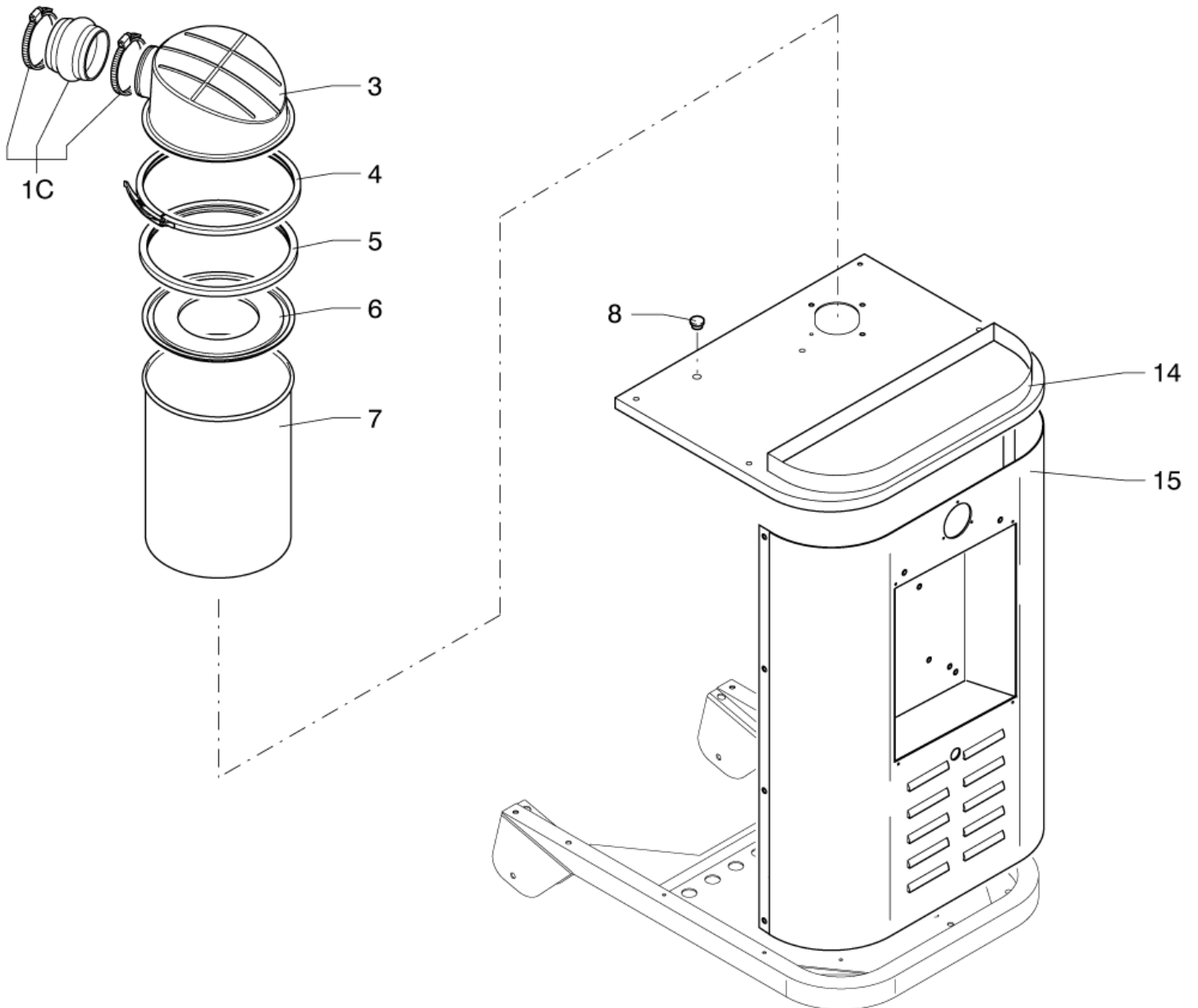

Frame 3

ATTIX 170

08-02-2015

Part List ID
A111X17005

10

Pos	Part no.	Qty	Description
3	4081200412	1	COVER 280 RAL 5005
4	Z8 36472	1	CLOSER 280
5	Z8 17640	1	JUNCTION D280
6	Z8 17631A	1	SUPERIOR TOP
7	4083000391	1	SAFETY FILTER CONT. 280 RAL 5005
8	Z8 39934	1	PLUG BLIND D18.5 RUBBER
14	4081600456	1	UPPER PLATE 3308-3508 RAL5005
15	4083500160	1	DOOR 3308-3508 RAL 5005
1C	40000545	1	KIT SLEEVE

Container unit

ATTIX 170

08-02-2015

Part List ID
ATTIX17007

11

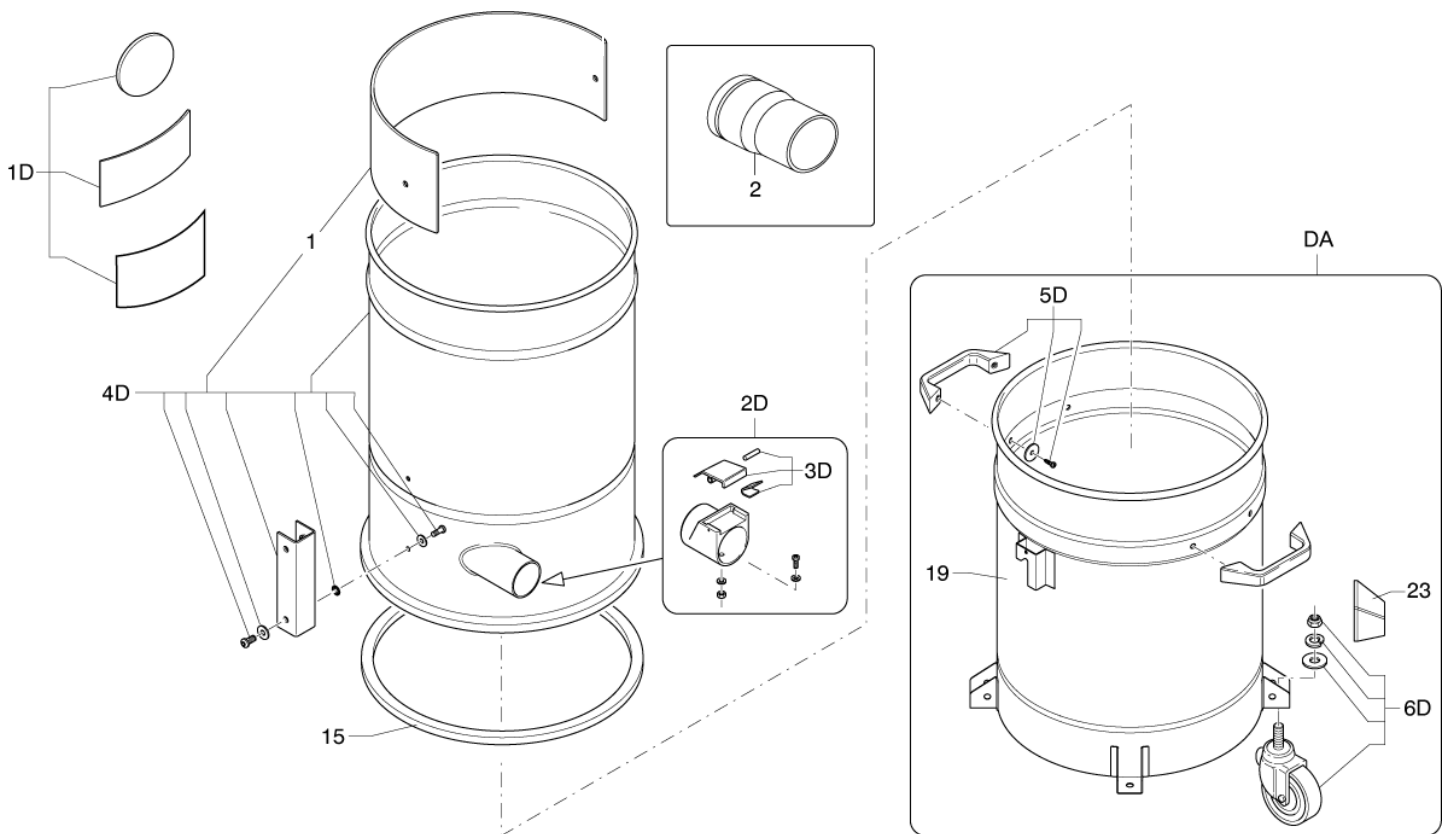

Container unit

ATTIX 170

08-02-2015

Part List ID
A111X17007

12

Pos	Part no.	Qty	Description
1	Z8 13225	1	SHIELD D460 MOD.3308 Z.PLT.
2	4072200392	1	ADAPTOR D70 CFM - D60 MULTIFIT
15	40000762	1	SEAL
19	Z8 30278 5005	1	CONTAINER D460x600 FE LT.100 MOD.3308
1D	40000633	1	KIT LABELS
23	Z8 17021	4	BUMPER WHEEL HOLDER
2D	40000549	1	COMPLETE INLET KIT D70 STRAIGHT
3D	40000345	1	KIT PUSHBUTTON FOR INLET D70
4D	40000634	1	KIT FILTER CHAMBER
5D	40000423	1	KIT HANDLE SS
6D	40000419	1	KIT CASTORS FOR CONTAINER
DA	Z8 30291 5005	1	CONT.D460x600 FE COMPL. LT.100 MOD. 3308

Filter group

ATTIX 170

08-02-2015

Part List ID
ATTIX17009

13

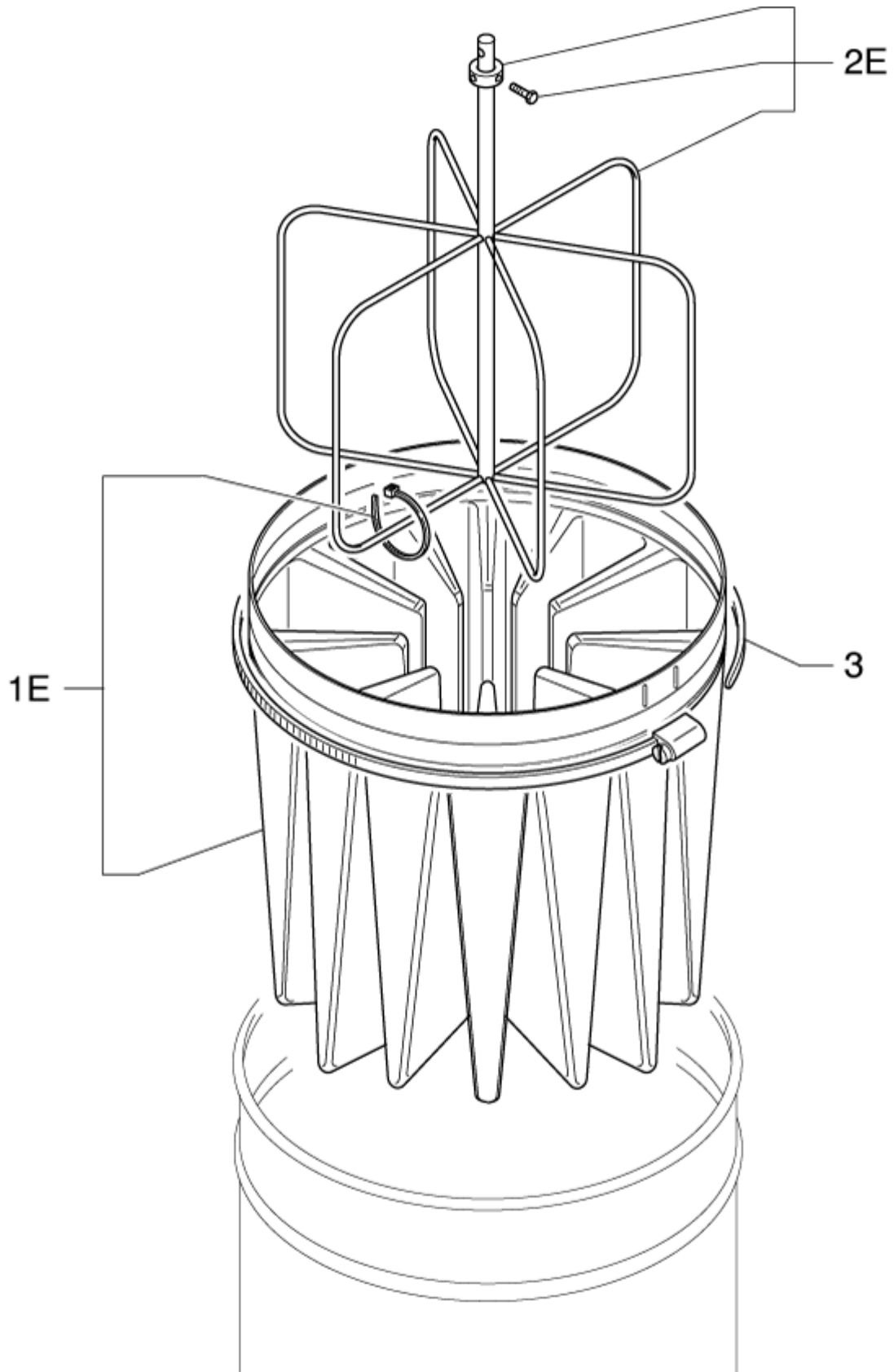

Filter group

ATTIX 170

08-02-2015

Part List ID
A111X17009

14

Pos	Part no.	Qty	Description
3	Z8 18079	1	FILTER BLOCK TIE D460
1E	40000338	1	KIT STAR FILTER D460 L CLASS
2E	40000550	1	FILTER CAGE KIT MOD. 3308

Manual shaker unit

ATTIX 170

08-02-2015

Part List ID
ATTIX17011

15

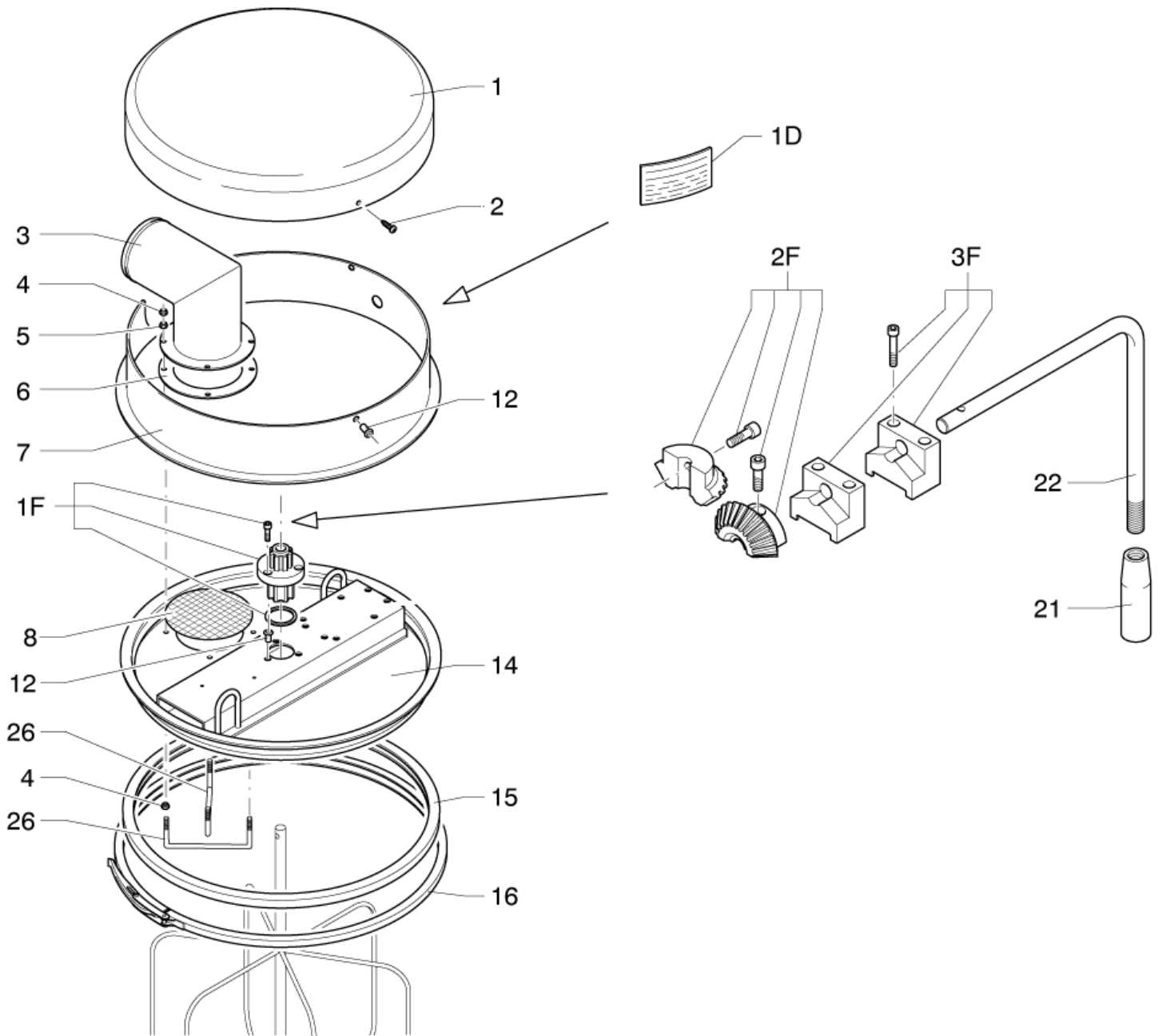

Manual shaker unit

ATTIX 170

08-02-2015

Part List ID
A11IX17011

16

Pos	Part no.	Qty	Description
1	4081200411	1	COVER 460 3308 RAL 9005
2		3	NOTE COMMENT Screw M6x16 UNI 7687 DIN 7985
3	Z8 32498	1	COLLECTOR D100
4		1	NOTE COMMENT Nut M6 UNI 5588 DIN 934
5		4	NOTE COMMENT Nut M6 UNI 7474 DIN 985
6	Z8 17056	1	INLET SEAL D100
7	4081100118	1	COLLAR D460 RAL 9005
8	Z8 13123	1	NET D150 MESH 6x6
12	Z8 38036	10	THREADED INSERT M6
15	Z8 17026	1	FILTER SEAL D460 BLACK
16	Z8 36191	1	BAND LOCK D.460
1F	40000551	1	FILTER SHAKER BUSH KIT
21	Z8 40813	1	HANDGRIP
22	Z8 14544	1	LEVER FOR FILTERSHAKER D460
26	Z8 18969	2	SPACER FOR FILTER 3308
2F	40000552	1	PINION KIT
3F	40000553	1	FILTER SHAKER SUPPORT KIT
14	4083500165	1	FILTER HOLDER - BEAM D460 RAL 9005

Electrical shaker unit - 1

ATTIX 170

08-02-2015

Part List ID
ATTIX17013

17

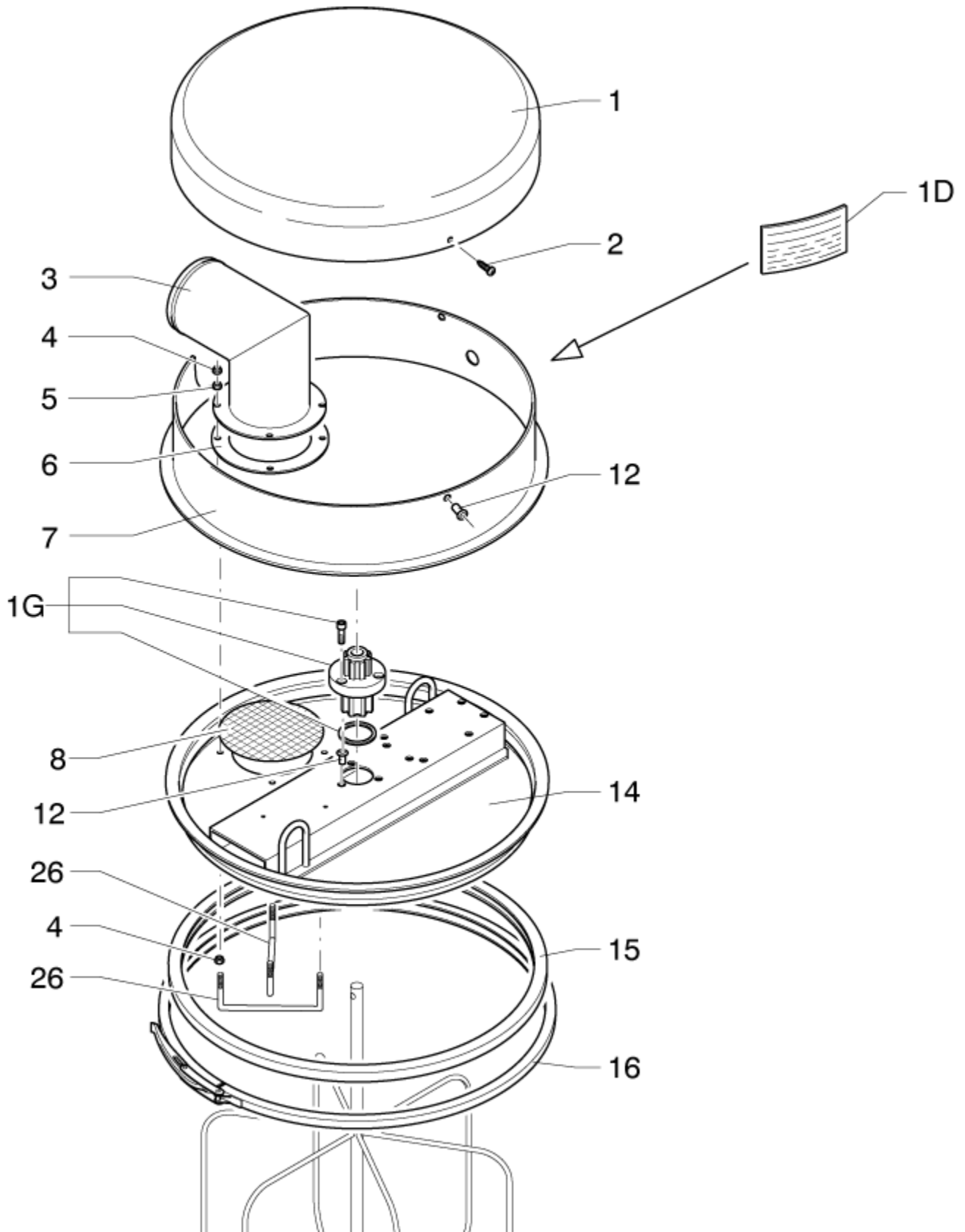

Electrical shaker unit - 1

ATTIX 170

08-02-2015

Part List ID
A11IX17013

18

Pos	Part no.	Qty	Description
1	4081200411	1	COVER 460 3308 RAL 9005
2		3	NOTE COMMENT Screw M6x16 UNI 7687 DIN 7985
3	Z8 32498	1	COLLECTOR D100
4		1	NOTE COMMENT Nut M6 UNI 5588 DIN 934
5		4	NOTE COMMENT Nut M6 UNI 7474 DIN 985
6	Z8 17056	1	INLET SEAL D100
7	4081100118	1	COLLAR D460 RAL 9005
8	Z8 13123	1	NET D150 MESH 6x6
12	Z8 38036	10	THREADED INSERT M6
14	4083500165	1	FILTER HOLDER - BEAM D460 RAL 9005
15	Z8 17026	1	FILTER SEAL D460 BLACK
16	Z8 36191	1	BAND LOCK D.460
1G	40000551	1	FILTER SHAKER BUSH KIT
26	Z8 18969	2	SPACER FOR FILTER 3308

Electrical shaker unit - 2

ATTIX 170

08-02-2015

Part List ID
ATTIX17015

19

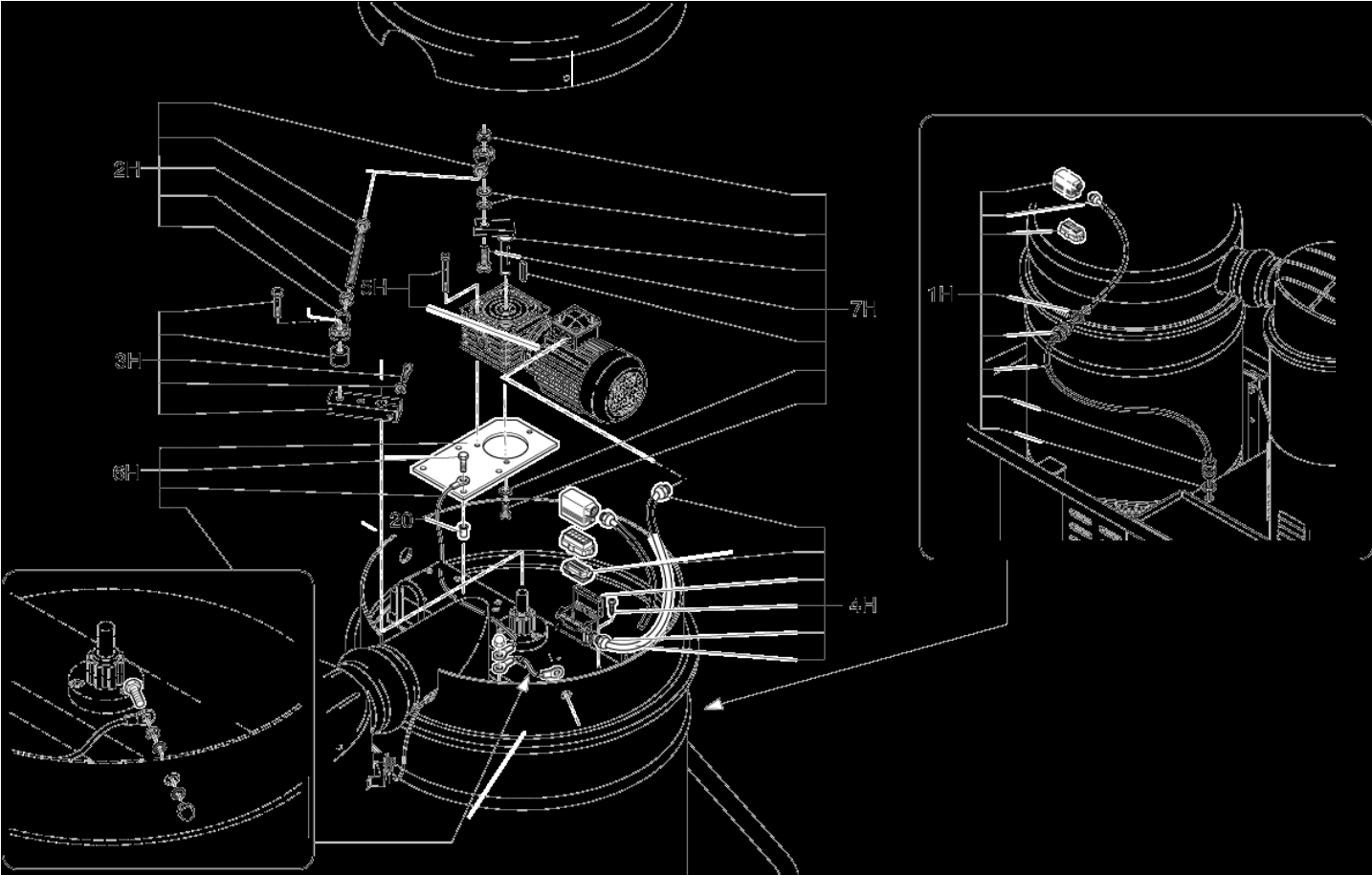

Electrical shaker unit - 2

ATTIX 170

08-02-2015

Part List ID
A111X17015

20

Pos	Part no.	Qty	Description
1H	40000748	1	MOBILE EL. FILTER SHAKER JUNCT
20	Z8 38036	4	THREADED INSERT M6
2H	40000749	1	FILTER SHAKER JOINT KIT
3H	40000750	1	FILTER SHAKER LEVER KIT
4H	40000751	1	FIX EL. FILTER SHAKER JUNCTION
5H	40000752	1	GEARMOTOR KIT D.460
6H	40000753	1	GEARMOTOR SUPPORT KIT
7H	40000754	1	PIN KIT FOR FILTER SHAKER

Suction unit

ATTIX 170

08-02-2015

Part List ID
ATTIX17017

21

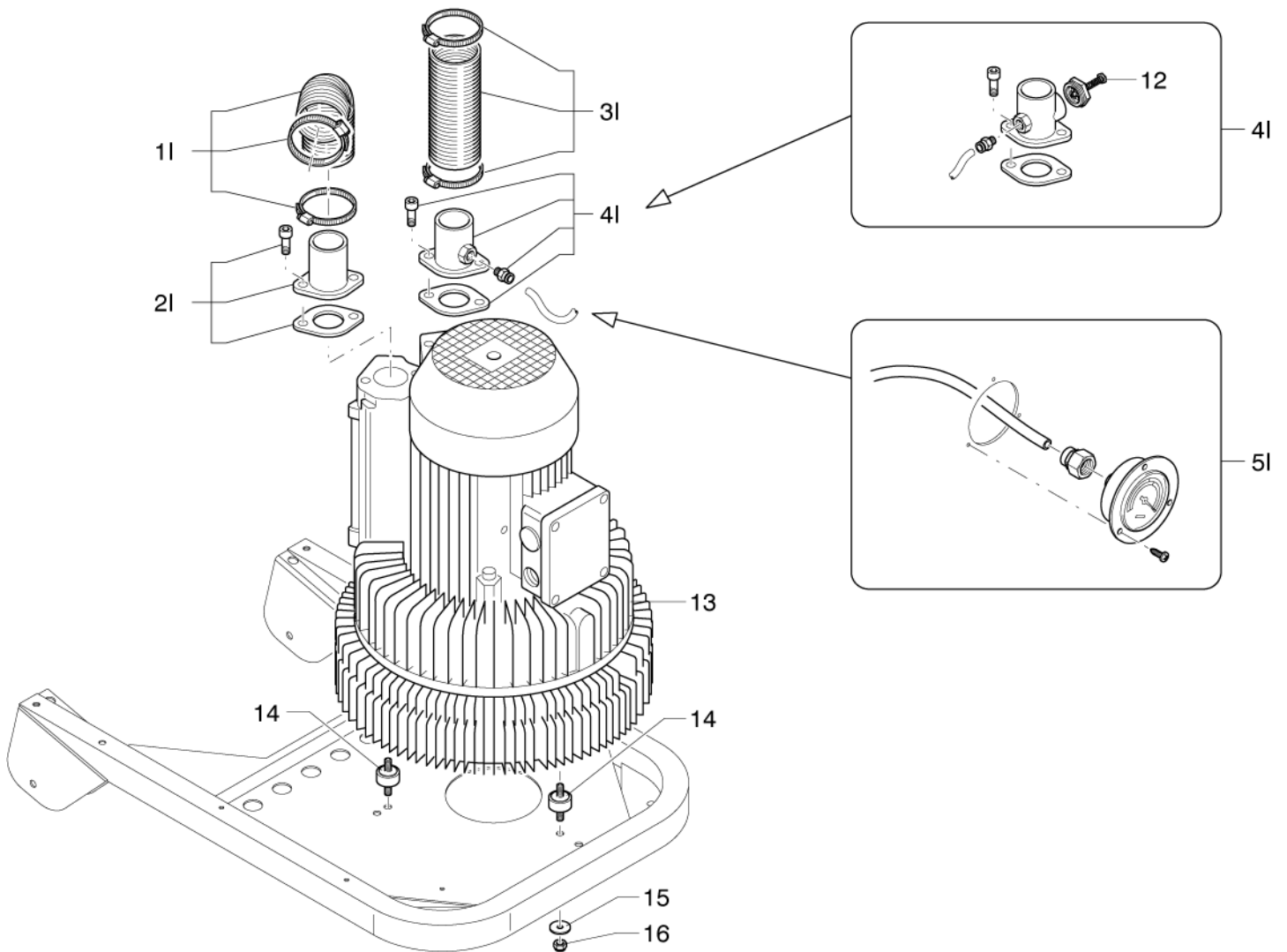

Suction unit

ATTIX 170

08-02-2015

Part List ID
A111X17017

22

Pos	Part no.	Qty	Description
12	Z8 34024	1	RELIEF VALVE 1 1/2
13	Z4 55055WHP5 5	1	BLOWER KW 4 V230/400/50
14	Z8 40068	3	PAD 40x30
15		3	NOTE COMMENT Washer D.10x30 UNI 6593 DIN 9021
16		3	NOTE COMMENT Nut M10 UNI 7474 DIN 985
11	40000557	1	KIT BLOWING TUBE
21	40000556	1	KIT BLOWING CONNECTION D70
31	40000572	1	KIT SUCTION TUBE
41	40000559	1	KIT SUCTION CONNECT. D70 WITH LIMIT.
51	40000555	1	KIT VACUUN GAUGE 3000

Electric system

ATTIX 170

08-02-2015

Part List ID
ATTIX17019

23

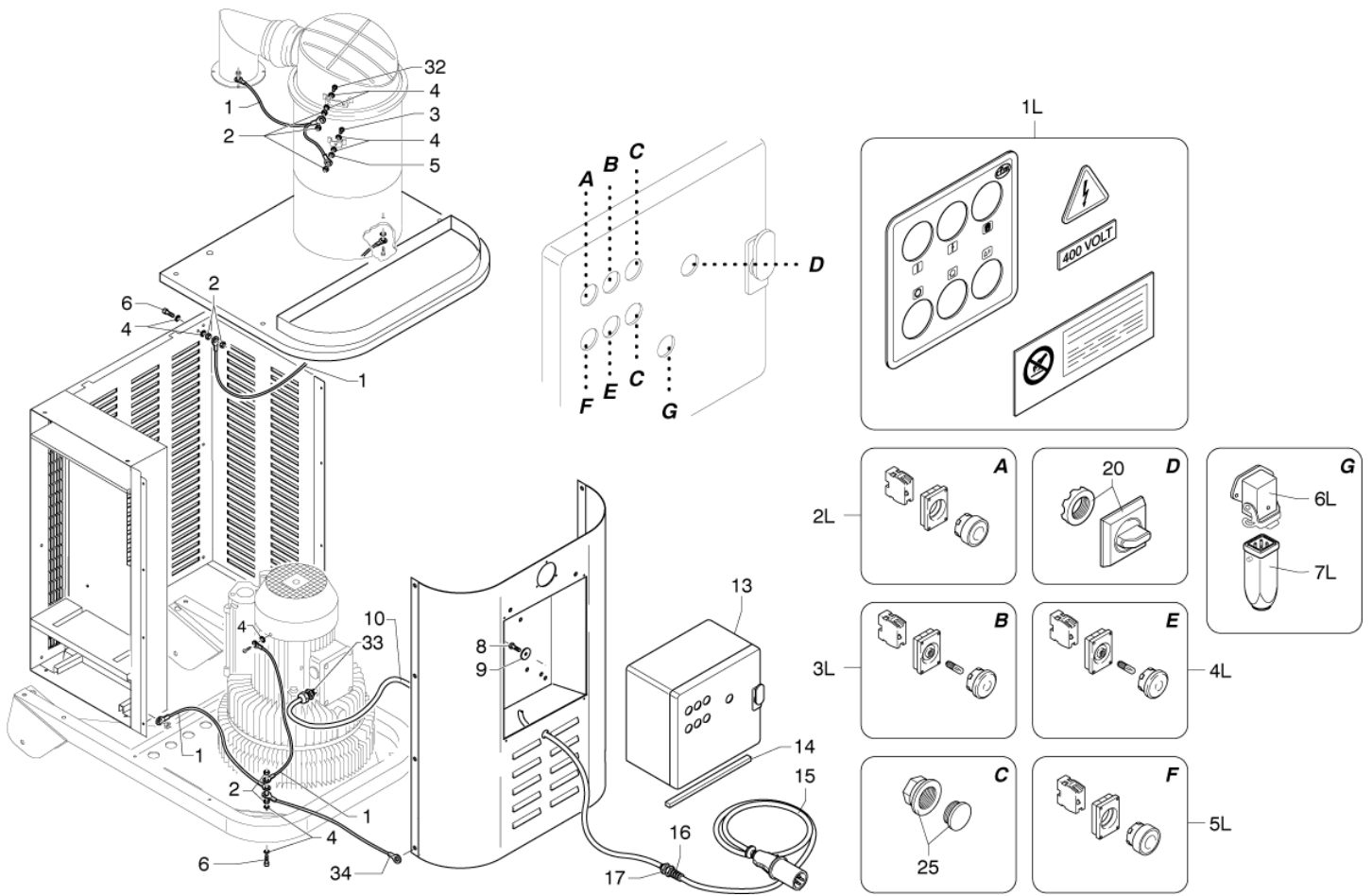

Electric system

ATTIX 170

08-02-2015

Part List ID
A11IX17019

24

Pos	Part no.	Qty	Description
1	Z8 391055	1	KIT GROUND CABLES MOTOR BOX
2		9	NOTE COMMENT Nut M6 UNI 5588 DIN 934
3		1	NOTE COMMENT Screw M6x10 UNI 5739 DIN 933
4		10	NOTE COMMENT Washer D.6 DIN 6798A
5		1	NOTE COMMENT Washer D.6 UNI 6592 DIN 433
6		3	NOTE COMMENT Screw M6x25 UNI 5739 DIN 933
7	Z8 39981	1	FAIRLEAD RUBBERISED D16
8		4	NOTE COMMENT Screw M8x20 UNI 5931 DIN 912
9		4	NOTE COMMENT Washer D.8x24 UNI 6593 DIN 9021
10	Z8 391079	1	CABLE CONN.MOT. 4G2.5 SIL. MOD.3508-T40
11		1	NOTE COMMENT Washer D.8 UNI 6592 DIN 433
12		1	NOTE COMMENT Screw M8x16 UNI 5931 DIN 912
13	4084100864	1	E.B. KW4 SE SF BOCC+PFC
13	4084100930	1	E.B. KW4 SF BOCC
14	40000765	1	SEAL
15	4083901287	1	CABLE SUP. 4G2.5 NE.SP16A 5PP 9M
16	Z8 39060	1	CABLE GLAND PG16 PA SPRING
17	Z8 39568	1	METAL RING NUT PG16
1L	40000561	1	ELECTRIC BOARD LABELS KIT
20	Z8 39924	1	HANDLING TO SIRIUS S0 CIRCUIT BREAKER
25	Z8 39522	2	PLUG BLIND CONTROL PLATE D22
2L	40000562	1	GREEN BUTTON KIT
32		1	NOTE COMMENT Screw M6x16 UNI 5739 DIN 933
33	Z8 39794	1	CABLE GLAND M32 PA
34	Z8 39669	1	CABLE EARTH MM 700
3L	40000563	1	WHITE INDICATOR KIT
4L	40000564	1	YELLOW INDICATOR KIT
5L	40000565	1	RED BUTTON KIT
6L	40000745	1	INLET PLUG KIT
7L	40000723	1	INLET CONNECTION KIT

Electric board manual shaker

ATTIX 170

08-02-2015

Part List ID
ATTIX17021

25

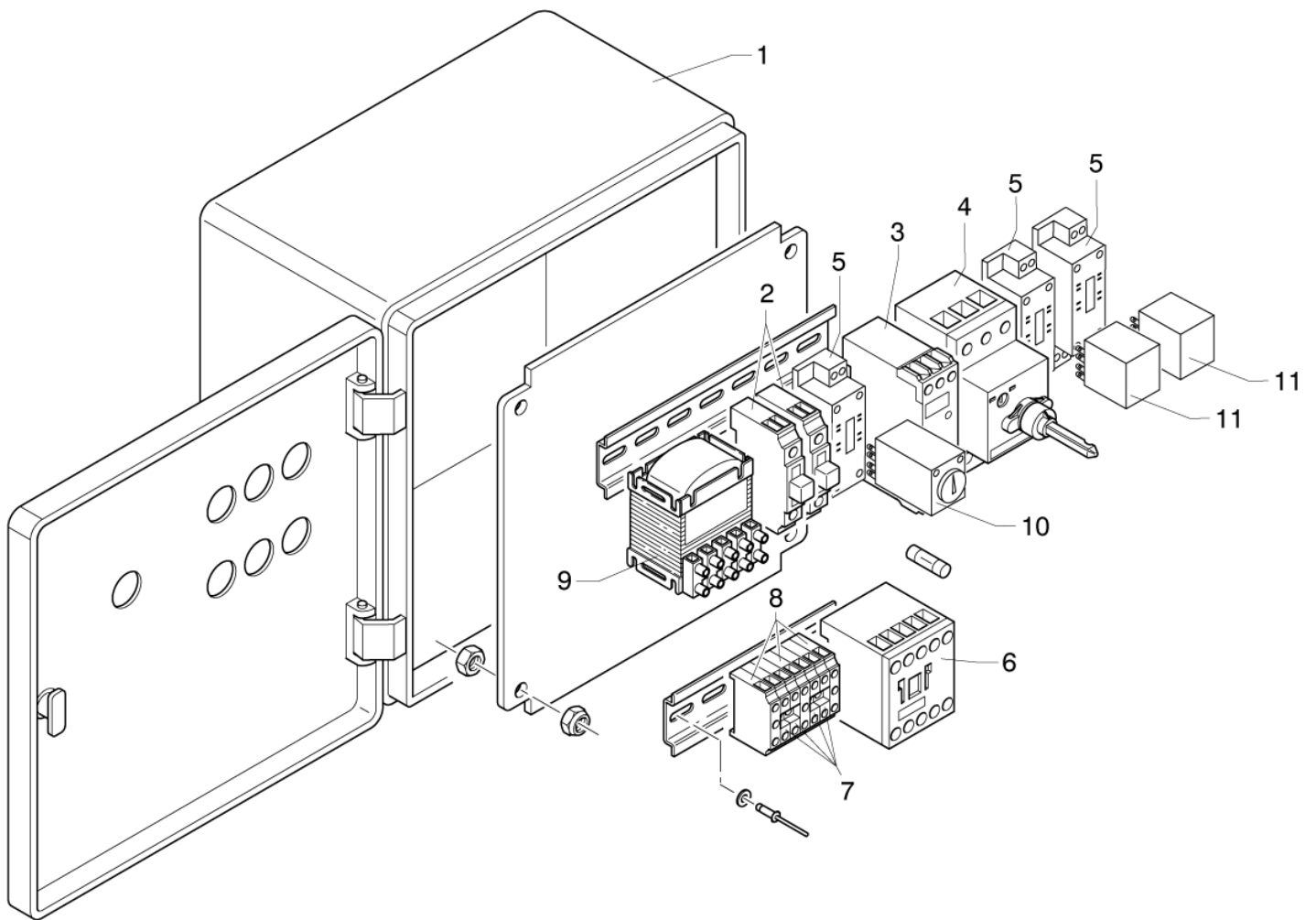

Electric board manual shaker

ATTIX 170

08-02-2015

Part List ID
A11IX17021

26

Pos	Part no.	Qty	Description
1	Z8 391031	1	CASE 300x300x160 IP65 DRILLED DRW. BxHxP
2	Z8 39244	2	TERMINAL FUSEHOLDER 1.5mmq S 5X20
3	Z8 391120	1	RELAY PHASE SEQUENCE 180-600V
4	Z8 39916	1	CIRCUIT BREAKER 9-12.5 A SIRIUS S0
5	Z8 39118	3	BASE x RELAY 2 EXCHANGES PYF
6	Z8 39281	1	CONTACTOR KW4 24VAC 1NO SIRIUS S00
7	Z8 39120	2	TERMINAL LINE 6MMQ S
8	Z8 39121	3	TERMINAL EARTH 6MMQ S
9	Z8 391050	1	TRANSFORMER 20VA 400-230/24V FUSE AT SEC
10	Z58 39415	1	TIMER 1S-10MIN 24VAC H3Y2 2 EXCHANGES
11	Z8 39259	2	RELAY 24VAC 2 EXCHANGES MY2

Electric board shaker unit

ATTIX 170

08-02-2015

Part List ID
ATTIX17023

27

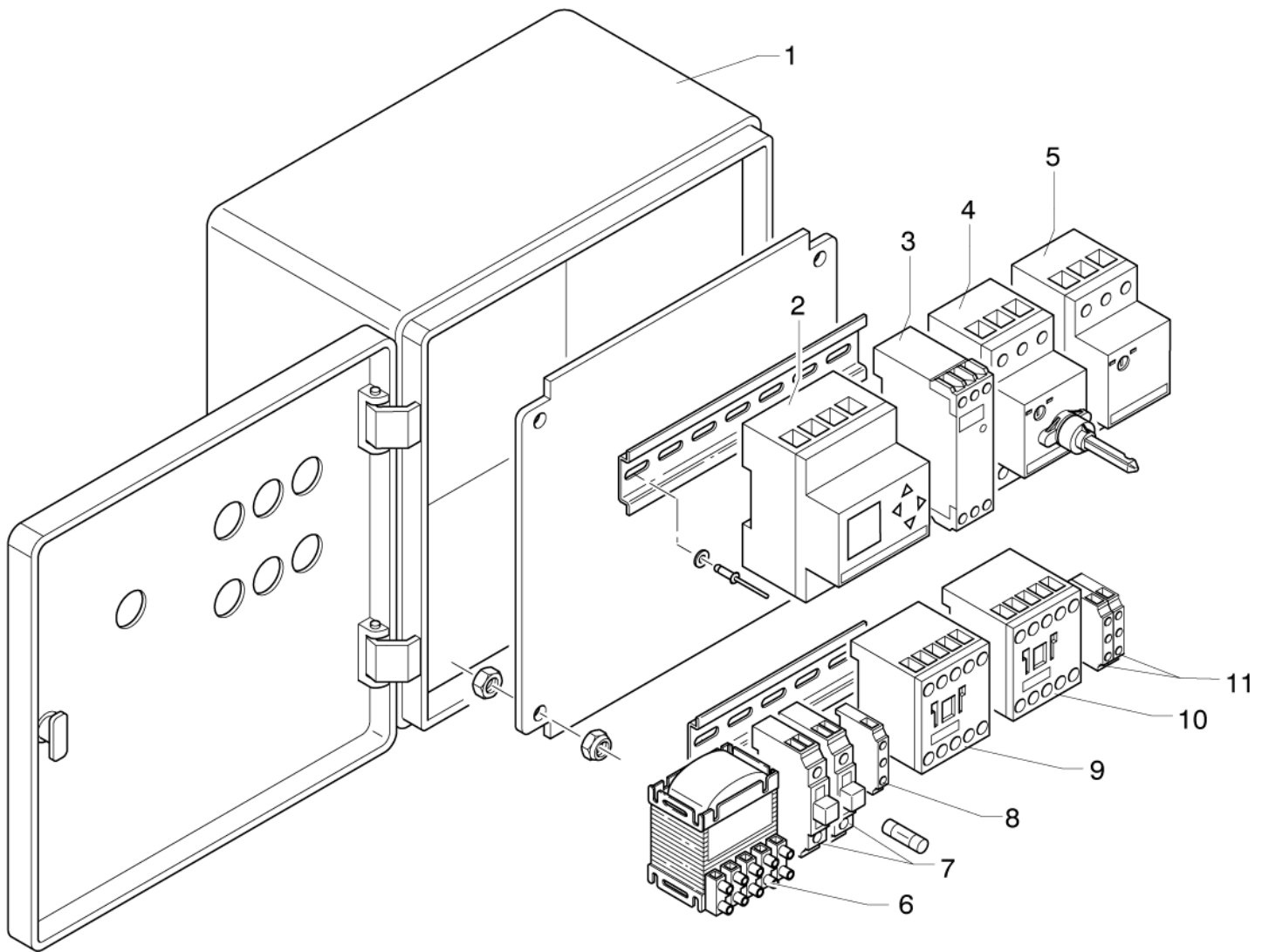

Electric board shaker unit

ATTIX 170

08-02-2015

Part List ID
A111X170Z3

28

Pos	Part no.	Qty	Description
1	Z8 391031	1	CASE 300x300x160 IP65 DRILLED DRW. BxHxP
2	Z58 39607	1	CONTROLLER LOGO 24RC 24VAC/DC 8IN/4OUT
3	Z8 391120	1	RELAY PHASE SEQUENCE 180-600V
4	Z8 39916	1	CIRCUIT BREAKER 9-12.5 A SIRIUS S0
5	Z8 39746	1	CIRCUIT BREAKER 0.7-1 A S00 SIRIUS S00
6	Z8 391050	1	TRANSFORMER 20VA 400-230/24V FUSE AT SEC
7	Z8 39244	2	TERMINAL FUSEHOLDER 1.5mmq S 5X20
8	Z8 39121	3	TERMINAL EARTH 6MMQ S
9	Z8 39281	1	CONTACTOR KW4 24VAC 1NO SIRIUS S00
10	Z8 391006	1	CONTACTOR KW3 24VAC 1NC SIRIUS S00