

FLOORTEC R 570 B

Model:
FLOORTEC R 570 P



Stückliste Deutsch

13-04-2015

Nilfisk
ALTO
works for you

www.nilfisk-alto.com

Inhalt

FLOORTEC R 570 B

Ansicht allgemein	3
Chassis lower	5
Chassis side - before S/N 070503310	7
Chassis side - starting from S/N 070503311	10
Haube Komplett	13
HAUPTBESEN	15
Right side broom	17
Left side broom	19
LENKSYSTEM	21
Front wheel	24
Pedal	26
Bedienfeld	28
ANTRIEBSSYSTEM	30
Dust control	32
ABFALLBEHÄLTER	34
Elektrokomponenten	36
Batterieladegerät	38
Zubehör 2	40
Zubehör 3	42

Ansicht allgemein

FLOORTEC R 570 B

13-04-2015

ET-Liste-Nr. R570B02

4

Pos	Artikelnr.	Me	Beschreibung
1	L08812362	2	Seilzug
2	33003976	1	Schraube M6x25
3	145 1252 000	1	Distanzstück ø6,5 x ø10 x 4,5
4	L08604251	2	WASHER 10X30 UNI6592
5	33005842	6	U-Scheibe
6	33005869	2	Dichtung M10 UNI8842A
7	145 4692 000	1	Batteriebehälter
7	146 2791 000	1	Batteriebehälter Set
8	33003814	2	SCREW M10X65 HEX HD P/THD ISO4014
9	33005445	6	Schraube M8x25
10	33005915	6	Unterlagscheibe 8x16
11	33005913	12	WASHER M6 UNI6592
12	145 9184 000	2	Feder
13	33003975	12	Schraube M6x20
14	33005851	10	Unterlegscheibe
15	L08228600	4	Dichtscheibe 6X18 UNI6592
16	33003962	1	Schraube M5x16
17	146 1851 000	2	Drehknopf M8
18	1463147000	1	Gasdruckfeder TSB 2007-006 R570 Main broom gas spring
19		1	NOTE COMMENT
20	146 2465 000	1	Abstandshalter
21	146 2469 000	1	Kabel Hauptbürste
22	146 2520 000	1	Kabel Seitenbürste links
23	146 2475 000	1	Kabel Seitenbürste rechts
24	146 2423 000	2	Anschlußstift
25	146 2470 000	2	Knopf M 6
26	146 2471 000	2	Handrad SR 1100 S
27	146 2736 000	1	Seitenbesenanhahrschutz RSR 1100 S
28	146 2737 000	1	Seitenbesenanhahrschutz LSR 1100 S
29		1	NOTE COMMENT Chassis
30		1	NOTE COMMENT Drive system
31		1	NOTE COMMENT Front wheel
32		1	NOTE COMMENT Steering system
33		1	NOTE COMMENT Main broom
34		1	NOTE COMMENT Right side broom
35		1	NOTE COMMENT Left side broom
36		1	NOTE COMMENT Bonnet system
37		1	NOTE COMMENT Accessories
38		1	NOTE COMMENT Waste container
39	146 2517 000	1	CLIP RUBBER PIPE RETAINING D.12
40	33005912	1	Unterlegscheibe M5

Chassis lower

FLOORTEC R 570 B

13-04-2015

ET-Liste-Nr.
R570B04

5

SEE SIDE BROOM ASSEMBLIES

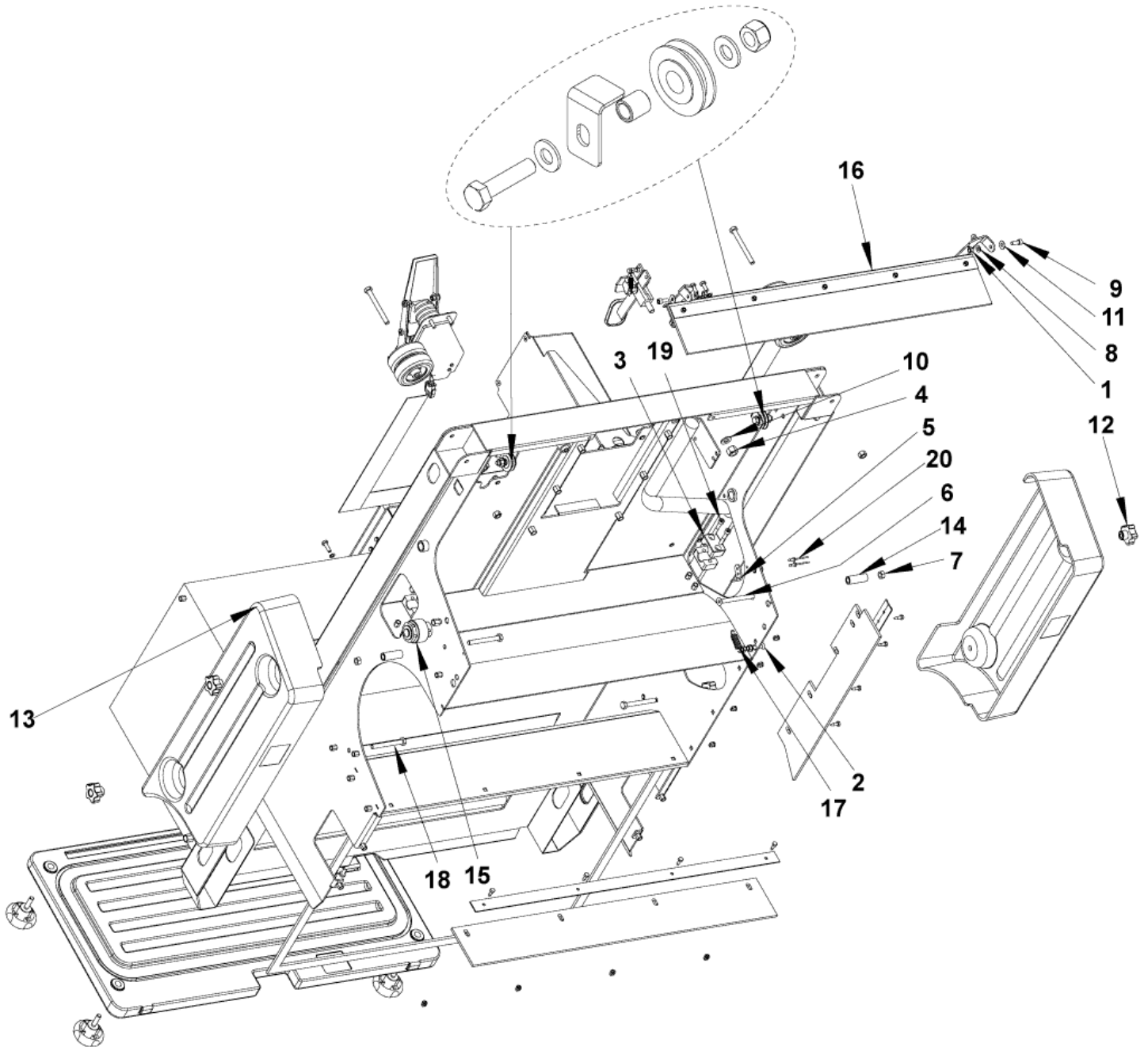

Chassis lower

FLOORTEC R 570 B

13-04-2015

ET-Liste-Nr.
R570B04

6

Pos	Artikelnr.	Me	Beschreibung
1	33005604	4	Mutter selbstsichernd M6 UNI7474
2	33004579	1	SCREW M6X25 C/SUNK FLAT HD HEX ISO10642
3	145 1891 000	4	Rohr ø18
4	33005566	2	Selbstsperrende MutterM10
5	145 5126 000	1	Rahmen
6	145 8946 000	1	Screw M8x 80 ISO 10642O
7	33005504	4	NUT HEX M8 UNI5588
8	33005913	5	WASHER M6 UNI6592
9	33004345	1	Schraube M6x16 UNI5931
10	33005916	1	Unterlagscheibe M10 UNI6592
11	146 0250 000	2	WASHER 6,4X16,3X1 UNI1739
12	146 1851 000	4	Drehknopf M8
13	146 2716 000	1	Klappe rechts
14	146 2426 000	4	Distanzstück
15	146 2487 000	1	Hupe 5-32V
16		1	NOTE COMMENT
17	145 9579 000	1	Feder
18	146 2425 000	3	SCREW M8X70 HEX HD F/THD SS ISO4017
19	33004350	4	SCREW M6X40 CAP HD HEX SOCK ISO4762
20	145 0491 000	2	RIVET 4

Chassis side - before S/N 070503310

FLOORTEC R 570 B

13-04-2015

ET-Liste-Nr.
R570B05

7

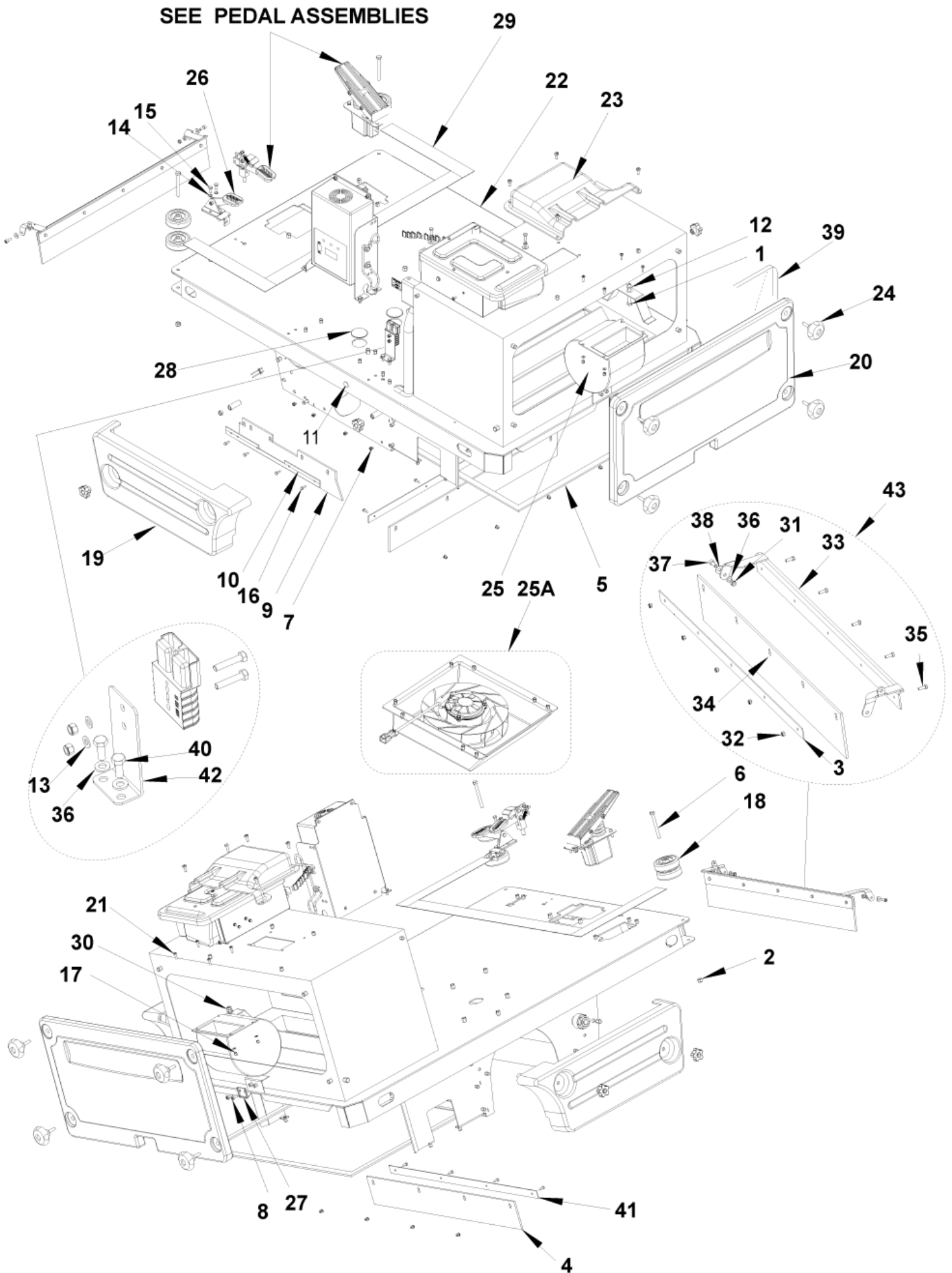

Chassis side - before S/N 070503310

FLOORTEC R 570 B

13-04-2015

ET-Liste-Nr. R570B05

8

Pos	Artikelnr.	Me	Beschreibung
0	146 2744 000	1	Schürze nicht abf ärbend
1	33004004	2	SCREW M8X70 HEX HD F/THD ISO4017
2	33005607	2	Mutter
3	145 1970 000	1	Klappe vorne
4	145 1971 000	1	Klappe hinten
5	146 2730 000	1	Dichtungskit
6	145 4477 000	2	Schraube M 8x80
7	145 4652 000	8	Schraube
8	L08812095	6	Schraube M6x16
9	145 5927 000	1	Leiste
10	145 5929 000	1	Seitenklappe
11	145 8008 000	1	Kappe ø18,2
12	33005915	4	Unterlagsscheibe 8x16
13	33005912	4	Unterlegscheibe M5
14	33005851	2	Unterlegscheibe
15	33003974	2	Schraube M6X16 UNI5739
16	145 9337 000	8	Schraube
17	33005561	4	NUT SELF L. M5 UNI7473
18	146 0945 000	4	Anlauf rolle
19	146 2715 000	1	Klappe links
20	146 2714 000	1	Filterklappe
21	146 2090 000	4	Schraube M5x16
22	146 2703 000	1	CHASSIS
23	146 2429 000	1	DEFLECTOR AIR
24	146 2427 000	4	Griff schraube M8x30
25	146 2794 000	1	MOTOR VACUUM KIT
26		1	NOTE COMMENT Pedal skirt raising device
27	145 9333 000	1	Klammerplatte
28	146 2418 000	2	CAP D.40.4
29	146 2798 000	1	Antirutsch-Kit
30		4	NUT HEX M8 UNI5588
31	33005604	1	Mutter selbstsichernd M6 UNI7474
32	33005603	5	Mutter
33	145 1840 000	1	Klappe
34	145 1969 000	1	Klappe vorne
35	33003961	5	Schraube M5x14
36	33005913	3	WASHER M6 UNI6592
37	33004345	1	Schraube M6x16 UNI5931
38	146 0250 000	1	WASHER 6,4X16,3X1 UNI1739
39	146 0741 000	1	Dichtung
40	33003974	2	Schraube M6X16 UNI5739
41	145 1972 000	1	Spritzgummileiste hinten
42	146 2384 000	1	Klammer

Chassis side - before S/N 070503310

FLOORTEC R 570 B

13-04-2015

ET-Liste-Nr. R570B05

9

Pos	Artikelnr.	Me	Beschreibung
43	1463190000	1	Spritzgummi AufhebungSR 1100 S
25A	1463195000	1	Saugmotorkit OPTION - INST.INSTR.1463196000 - TSB IT 2007-004

Chassis side - starting from S/N 070503311

FLOORTEC R 570 B

13-04-2015

ET-Liste-Nr. R570B06

10

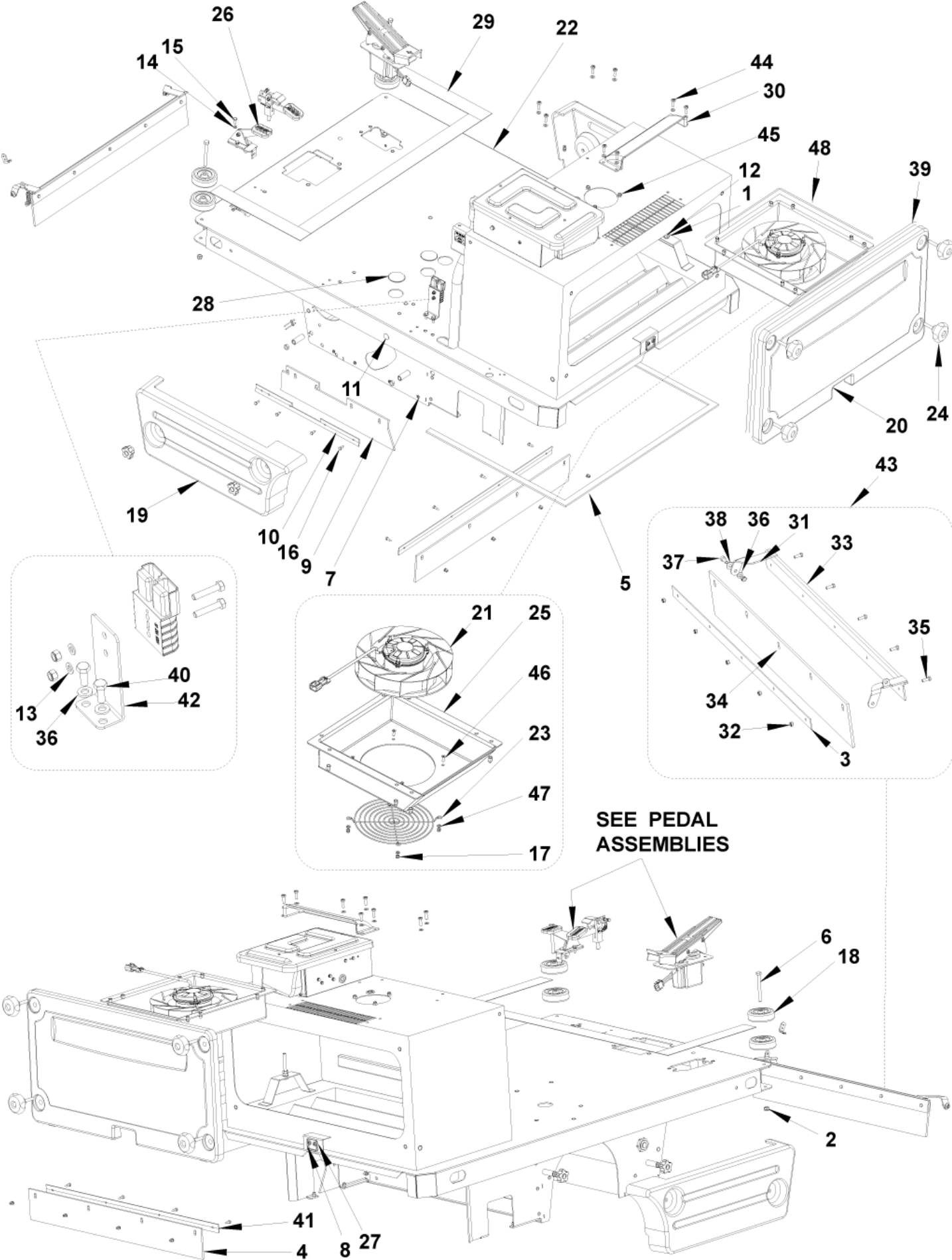

Chassis side - starting from S/N 070503311

FLOORTEC R 570 B

13-04-2015

ET-Liste-Nr. R570B06

11

Pos	Artikelnr.	Me	Beschreibung
0	146 2744 000	1	Schürze nicht abf ärbend
1	33004004	2	SCREW M8X70 HEX HD F/THD ISO4017
2	33005607	2	Mutter
3	145 1970 000	1	Klappe vorne
4	145 1971 000	1	Klappe hinten
5	146 2730 000	1	Dichtungskit
6	145 4477 000	2	Schraube M 8x80
7	145 4652 000	8	Schraube
8	L08812095	6	Schraube M6x16
9	145 5927 000	1	Leiste
10	145 5929 000	1	Seitenklappe
11	145 8008 000	1	Kappe ø18,2
12	33005915	4	Unterlagsscheibe 8x16
13	33005912	4	Unterlegscheibe M5
14	33005851	2	Unterlegscheibe
15	33003974	2	Schraube M6X16 UNI5739
16	145 9337 000	8	Schraube
17	33005561	4	NUT SELF L. M5 UNI7473
18	146 0945 000	4	Anlauf rolle
19	146 2715 000	1	Klappe links
20	146 2714 000	1	Filterklappe
21	1463146000	1	Saugmotor
22	1463159000	1	CHASSIS
23	1463182000	1	GRATE PROTECTION
24	146 2427 000	4	Griff schraube M8x30
25	1463217000	1	CONVEYOR
26		1	NOTE COMMENT Pedal skirt raising device
27	145 9333 000	1	Klammerplatte
28	146 2418 000	2	CAP D.40.4
29	146 2798 000	1	Antirutsch-Kit
30	1463218000	1	CONVEYOR
31	33005604	1	Mutter selbstsichernd M6 UNI7474
32	33005603	5	Mutter
33	145 1840 000	1	Klappe
34	145 1969 000	1	Klappe vorne
35	33003961	5	Schraube M5x14
36	33005913	14	WASHER M6 UNI6592
37	33004345	1	Schraube M6x16 UNI5931
38	146 0250 000	1	WASHER 6,4X16,3X1 UNI1739
39	146 0741 000	1	Dichtung
40	33003974	2	Schraube M6X16 UNI5739
41	145 1972 000	1	Spritzgummileiste hinten
42	146 2384 000	1	Klammer

Chassis side - starting from S/N 070503311

FLOORTEC R 570 B

13-04-2015

ET-Liste-Nr. R570B06

12

Pos	Artikelnr.	Me	Beschreibung
43	1463190000	1	Spritzgummi AufhebungSR 1100 S
44	909 6440 000	8	SCREW M6X20 PAN HD PHIL ISO7045
45	33005562	3	Mutter M6
46	145 5808 000	4	SCREW M5X16 C/SUNK FLAT HD PHIL ISO7046
47	33005912	4	Unterlegscheibe M5
48	1463173000	4	GASKET CONVEYOR

Haube Komplet

FLOORTEC R 570 B

13-04-2015

ET-Liste-Nr.
R570B08

13

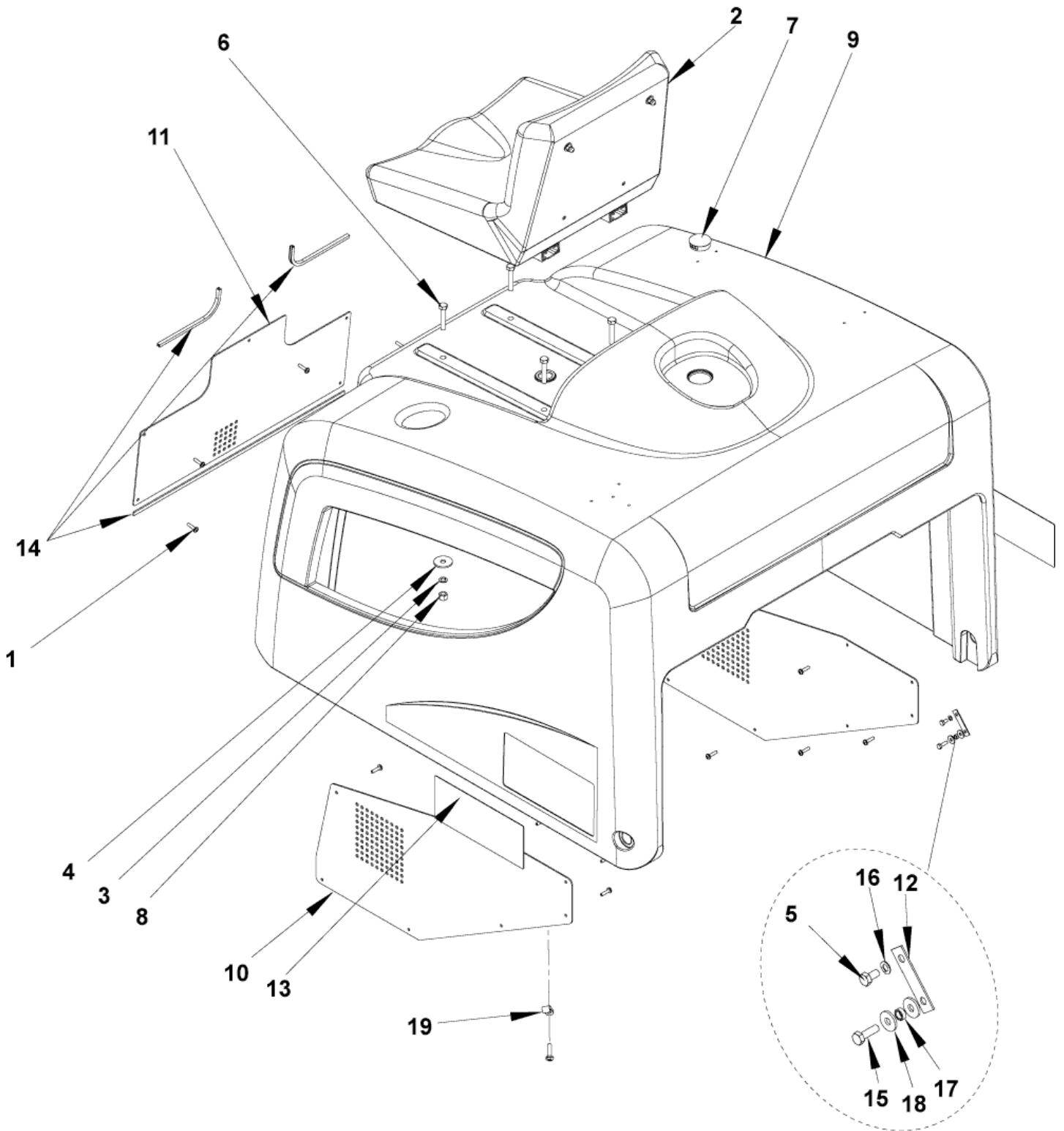

Haube Komplett

FLOORTEC R 570 B

13-04-2015

ET-Liste-Nr. R570B08

14

Pos	Artikelnr.	Me	Beschreibung
0	146 0336 000	1	Mikroschalter
0	146 2488 000	1	HARNESS BONNET
1	L08812590	19	SCREW 4.5X19 SELF PAN HD PHIL F PLASTIC
2	145 1782 000	1	Mikroschalter Sitz
2	146 2900 000	1	SEAT WITH BELT
3	33005842	4	U-Scheibe
4	145 9171 000	4	Scheibe 8 x 24
5	33003972	2	Schraube M6 x 12
6	33004000	4	SCREW M8X50 HEX HD F/THD ISO4017
7	145 9835 000	1	CAP D.38.1
8	146 1567 000	4	Nut HEX M8 Uni 5587
9	146 2713 000	1	Haube Sitzhalter
10	146 2421 000	1	GRATE SIDE
11	146 2422 000	1	GRATE FRONT
12	146 2424 000	2	PLATE CABLE FIXING
13	1463750000	1	DECALS FLOORTEC R 570 B KIT
13	1463751000	1	DECALS FLOORTEC R 570 P KIT
14	146 2801 000	1	GASKET RUBBER FOR BONNET KIT
15	33003975	2	Schraube M6x20
16	33005851	2	Unterlegscheibe
17	145 1252 000	2	Distanzstück ø6,5 x ø10 x 4,5
18	L08228600	4	Dichtscheibe 6X18 UNI6592
19	L08603845	6	Kabelklemme
20	146 2546 000	1	GRATE SIDE

HAUPTBESEN

FLOORTEC R 570 B

13-04-2015

ET-Liste-Nr.
R570B10

15

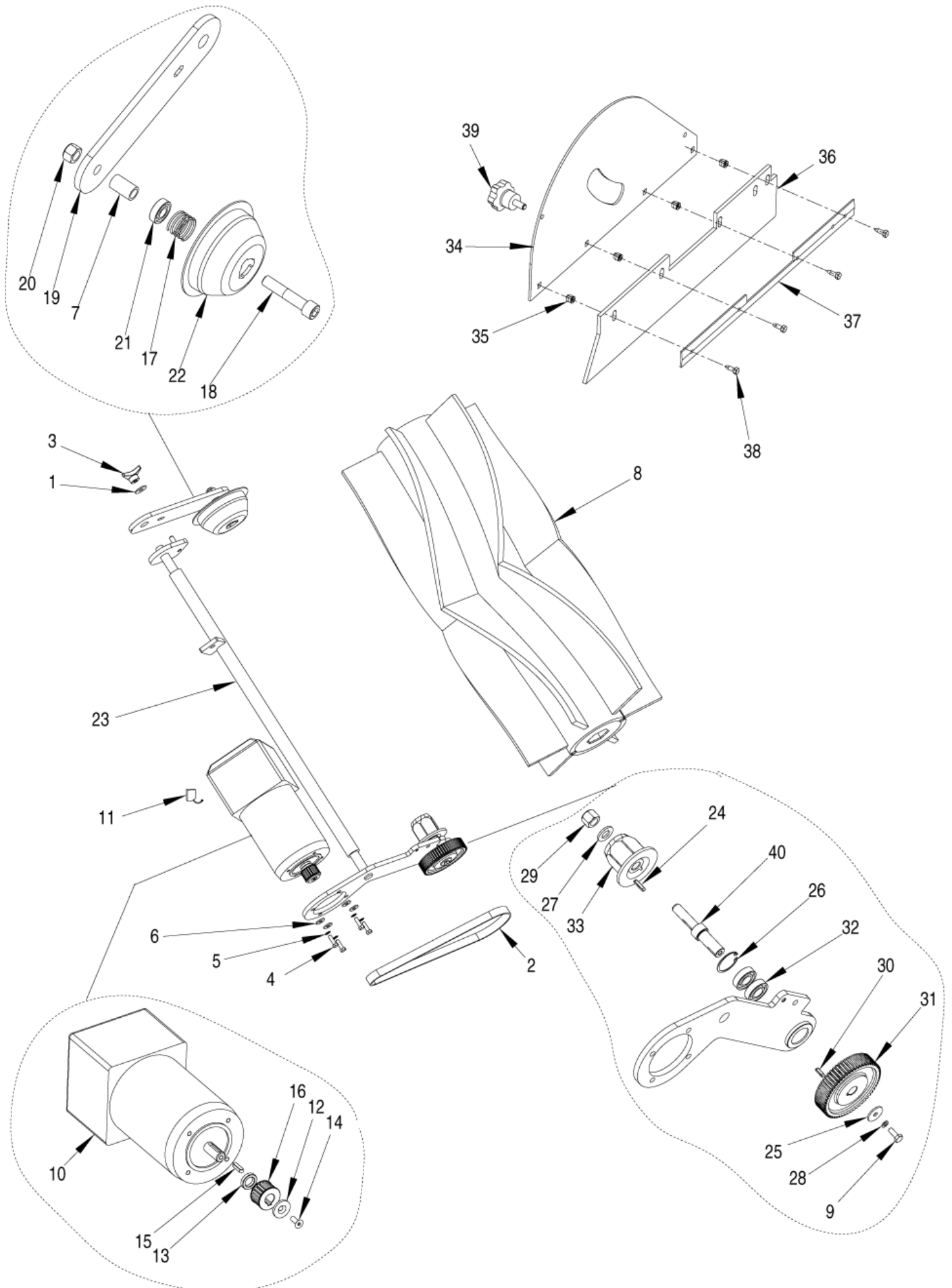

HAUPTBESEN

FLOORTEC R 570 B

13-04-2015

ET-Liste-Nr. R570B10

16

Pos	Artikelnr.	Me	Beschreibung	
0	146 2743 000	1	Teppichkehrset f. SR1100S	OPTION - INST.INTR.146 2742 000
1	145 1344 000	1	U-Scheibe 8x24 SS	
2	145 1851 000	1	Riemen	
3	145 5035 000	1	Griff	
4	33003975	4	Schraube M6x20	
5	33005851	4	Unterlegscheibe	
6	L08228600	4	Dichtscheibe 6X18 UNI6592	
7	145 2662 000	1	Distanzstück ø12 x ø17 x 28	
8	145 4879 000	1	Hauptkehrbürste 300 x 700	
8	145 4957 000	1	Hauptbürste	
8	145 6080 000	1	Hauptbürste	
9	33003974	1	Schraube M6X16 UNI5739	
10	146 2792 000	1	MOTOR, BROOM MAIN KIT	
11	1464432000	1	Kohle Kit 4 Stück	
12	145 5828 000	1	Distanzstück	
13	145 1950 000	1	Distanzstück ø14 x ø23 x 5	
14	33004576	1	Schraube M6X16 UNI5933	
15	1466147000	1	KEY 5X5X20 UNI6604A PKD	
16	145 1849 000	1	Riemenscheibe HTD 20 5M 15 6F	
17	145 0271 000	1	Feder	
18	33004442	1	Schraube M12X60 UNI5931	
19	145 1845 000	1	Bürstenhebel zentral	
20	146 0973 000	1	Mutter selbstsichernd L. M12 UNI7474	
21	145 0270 000	1	Kugellager 6001 2RS	
22	145 0269 000	1	Nabe	
23	146 2464 000	1	Schaft für Hauptbesen	
24	145 8197 000	1	Passfeder 4 x 4 x 20 DIN 6885	
25	1466332000	1	WASHER 6X24X2 UNI6593 10 PCS SET	set includes 10 pcs
26	33006162	1	RING D 32 UNI7437	
27	33003720	2	U-Scheibe	
28	33005865	1	U-Scheibe M6	
29	L08601000	1	Sechskantmutter M12	
30	146 1489 000	1	Feder 4x4x15	
31	145 1850 000	1	Riemenscheibe HTD 60 5M 15 6W	
32	145 8196 000	2	KUGELLAGER	
33	1463877000	1	Nabe Kehrwalze	SEE TSB IT 2008-023
34	146 2416 000	1	Klappe Hauptbesen	
35	145 4652 000	4	Schraube	
36	145 5927 000	1	Leiste	
37	145 5929 000	1	Seitenklappe	
38	145 9337 000	4	Schraube	
39	1466153000	2	KNOB LOBED M6X15 PKD	
40	145 1791 000	1	Bürstenstift zentral	

Right side broom

FLOORTEC R 570 B

13-04-2015

ET-Liste-Nr. R570B12

17

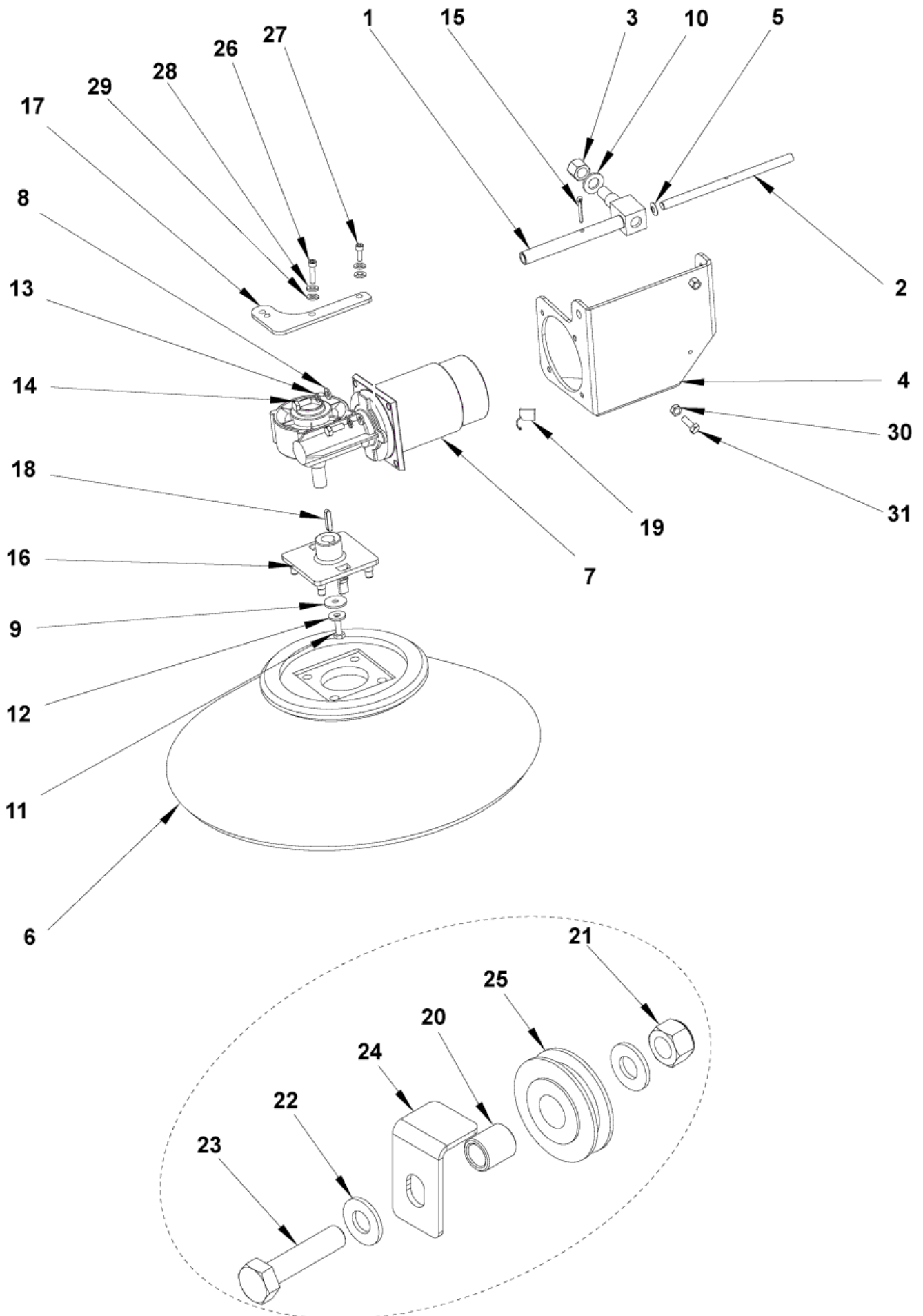

Right side broom

FLOORTEC R 570 B

13-04-2015

ET-Liste-Nr. R570B12

18

Pos	Artikelnr.	Me	Beschreibung	
1	145 1792 000	1	Stift Seitenbürste	
2	145 1951 000	1	Stift Seitenbürste	
3	L08601000	1	Sechskantmutter M12	
4	1463151000	1	Halterung f. Seitenbesen	
5	145 2644 000	1	Feder 6,2 x 15 x 0,5	
6	145 4959 000	1	Seitenbürste	Stahlmi
6	145 4976 000	1	Seitenbürste	natur Fiber
7	1463198000	1	Reduktion Getriebe60 W	TSB_IT 2007_007 R570 Side broom gearmotor
8	33005913	4	WASHER M6 UNI6592	
9	1466332000	1	WASHER 6X24X2 UNI6593 10 PCS SET	set includes 10 pcs
10	33003720	1	U-Scheibe	
11	33003975	1	Schraube M6x20	
12	L08228600	1	Dichtscheibe 6X18 UNI6592	
13	33005865	4	U-Scheibe M6	
14	33003974	4	Schraube M6X16 UNI5739	
15	145 9624 000	1	Split pin 3x20 ISO 1234	
16	146 0402 000	1	FLANGE BROOM HOLDING	
17	1464355000	1	Halter f. Seitenbesen-	
18	1466146000	1	KEY 5X5X25 UNI6604A PKD	
19	145 5125 000	2	CARBON BRUSH	
20	909 5312 000	1	Rolle 8.2x12x13.5	
21	33005607	1	Mutter	
22	33005915	2	Unterlagsscheibe 8x16	
23	33003997	1	Schraube M8X35 UNI5739	
24	146 2476 000	1	Kabelhalter	
25	145 2612 000	1	Riemenscheibe	
26	146 1714 000	1	Schraube M5X45 UNI5931	
27	33004326	1	Schraube M5 X12	
28	33005839	2	U-Scheibe M5	
29	33005912	2	Unterlegscheibe M5	
30	33005504	1	NUT HEX M8 UNI5588	
31	33003998	1	Schraube M8x40	

Left side broom

FLOORTEC R 570 B

13-04-2015

ET-Liste-Nr. R570B14

19

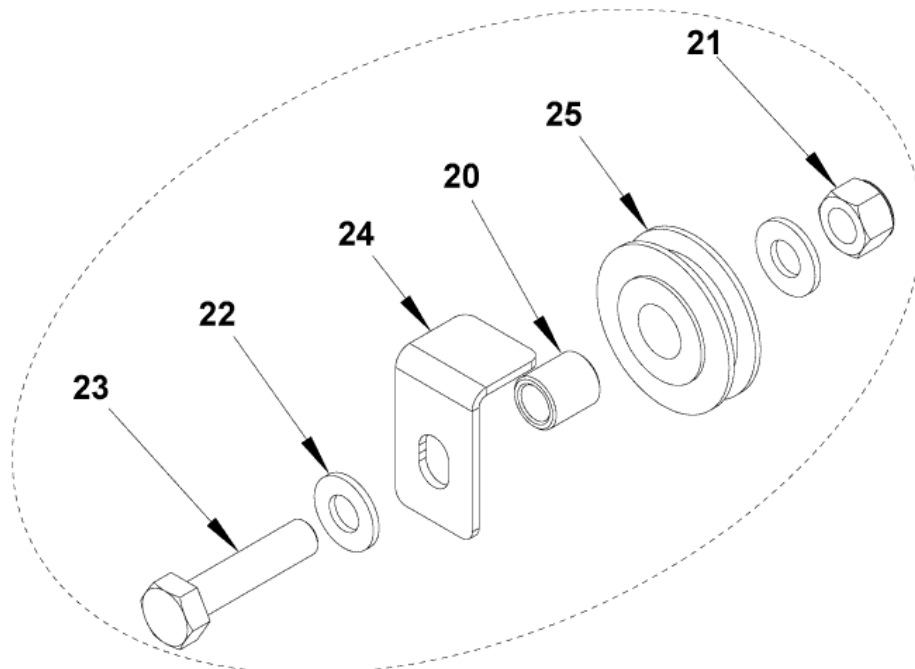
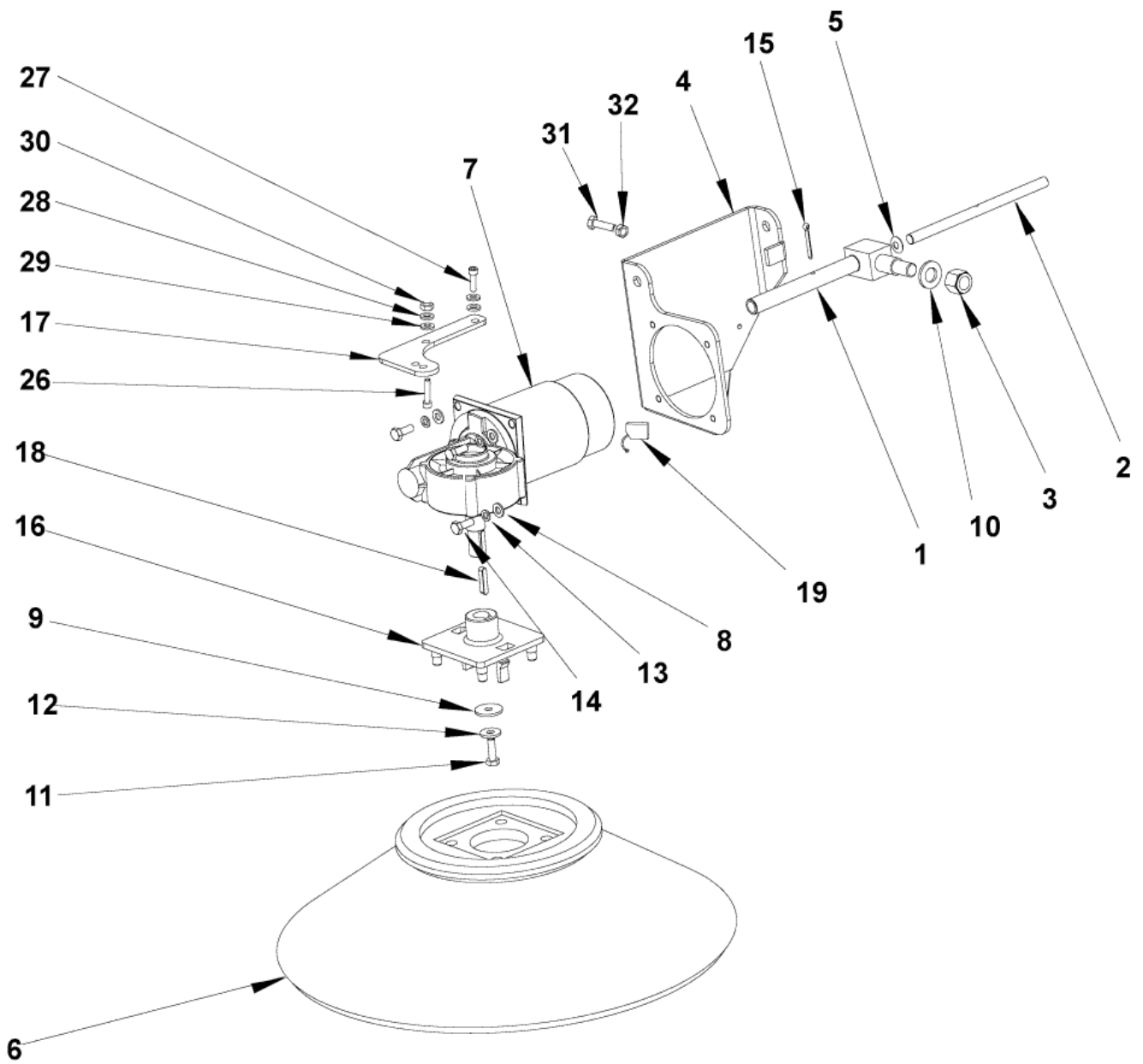

Left side broom

FLOORTEC R 570 B

13-04-2015

ET-Liste-Nr. R570B14

20

Pos	Artikelnr.	Me	Beschreibung	
1	145 1792 000	1	Stift Seitenbürste	
2	145 1951 000	1	Stift Seitenbürste	
3	L08601000	1	Sechskantmutter M12	
4	1463153000	1	SUPPORT LEFT SIDE BROOM	
5	145 2644 000	1	Feder 6,2 x 15 x 0,5	
6	145 4959 000	1	Seitenbürste	Stahlmi
6	145 4976 000	1	Seitenbürste	natur Fiber
7	1463197000	1	Reduktion Getriebemotor60 W	TSB_IT 2007_007 R570 Side broom gearmotor
8	33005913	4	WASHER M6 UNI6592	
9	1466332000	1	WASHER 6X24X2 UNI6593 10 PCS SET	set includes 10 pcs
10	33003720	1	U-Scheibe	
11	33003975	1	Schraube M6x20	
12	L08228600	1	Dichtscheibe 6X18 UNI6592	
13	33005865	4	U-Scheibe M6	
14	33003974	4	Schraube M6X16 UNI5739	
15	145 9624 000	1	Split pin 3x20 ISO 1234	
16	146 0402 000	1	FLANGE BROOM HOLDING	
17	1464355000	1	Halter f. Seitenbesen-	
18	1466146000	1	KEY 5X5X25 UNI6604A PKD	
19	145 5125 000	2	CARBON BRUSH	
20	909 5312 000	1	Rolle 8.2x12x13.5	
21	33005607	1	Mutter	
22	33005915	2	Unterlagsscheibe 8x16	
23	33003997	1	Schraube M8X35 UNI5739	
24	146 2476 000	1	Kabelhalter	
25	145 2612 000	1	Riemenscheibe	
26	146 1714 000	1	Schraube M5X45 UNI5931	
27	33004328	1	Schraube M 5 x 16	
28	33005839	2	U-Scheibe M5	
29	33005912	2	Unterlegscheibe M5	
30	33005691	1	Mutter M5	
31	33003998	1	Schraube M8x40	
32	33005504	1	NUT HEX M8 UNI5588	

LENKSYSTEM

FLOORTEC R 570 B

13-04-2015

ET-Liste-Nr.
R570B16

21

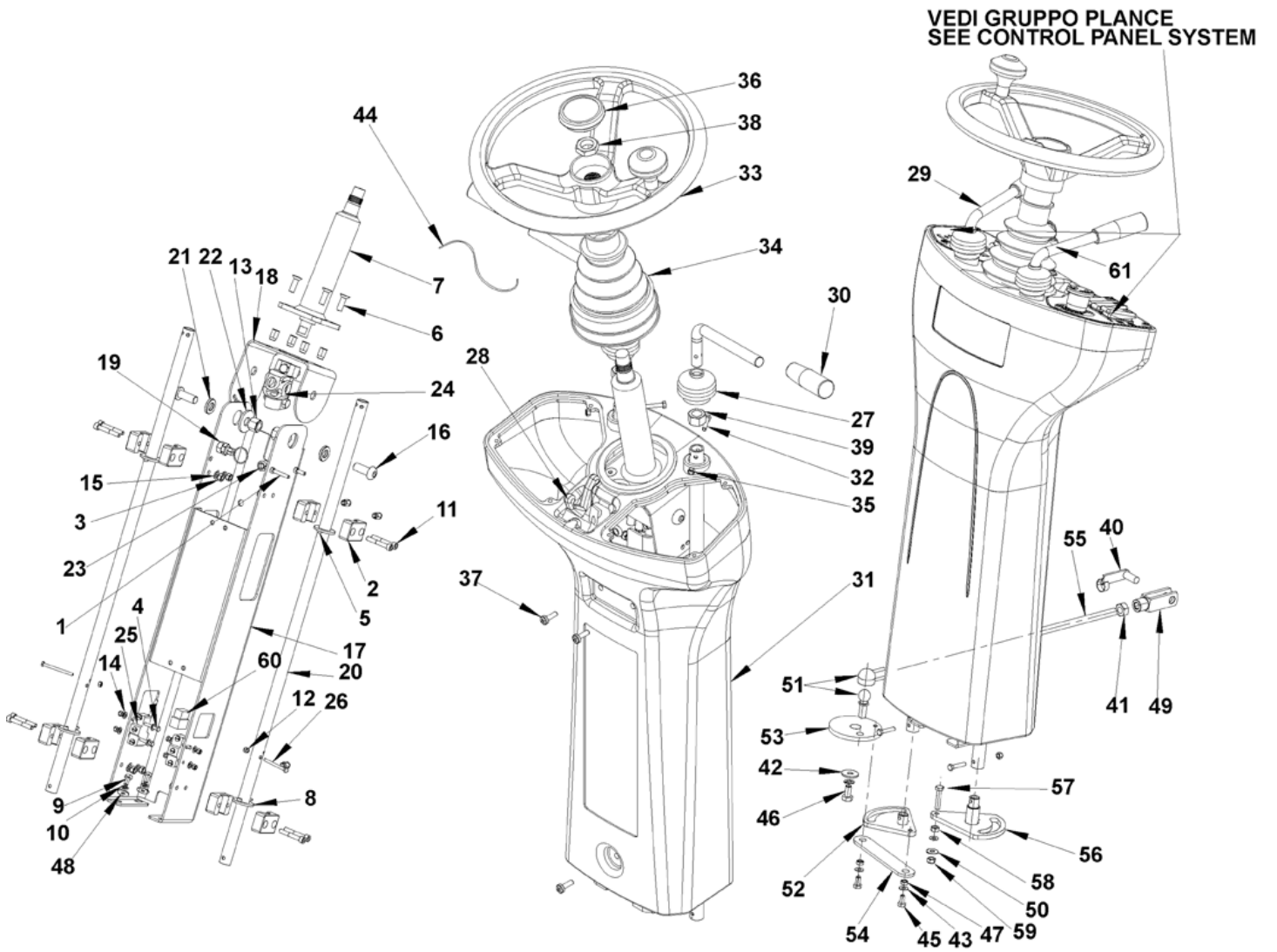

LENKSYSTEM

FLOORTEC R 570 B

13-04-2015

ET-Liste-Nr. R570B16

22

Pos	Artikelnr.	Me	Beschreibung
1	33005691	4	Mutter M5
2	145 1891 000	8	Rohr ø18
3	33005604	8	Mutter selbstsichernd M6 UNI7474
4	33003953	4	SCREW M4X30 HEX HD F/THD ISO4017
5	33005786	4	PIN SPLIT 4X25 UNI1336
6	33004593	4	SCREW M8X25 C/SUNK FLAT HD HEX ISO10642
7	145 1946 000	1	Lenksäule
8	33005920	4	Distanzring
9	33005444	4	Schraube M8x20 verzinkt
10	33005842	5	U-Scheibe
11	33004350	8	SCREW M6X40 CAP HD HEX SOCK ISO4762
12	33005602	6	NUT SELF L. M4 UNI7473
13	33005571	2	NUT M12X1.25 UNI7473
14	33005912	8	Unterlegscheibe M5
15	33005875	8	WASHER M6 UNI6592 SS
16	146 1011 000	2	SCREW M12X30 BUTTON HD HEX SOCK ISO7380
17	1465515000	1	COLUMN STEERING KIT
18	1465516000	1	SUPPORT STEERING COLUMN KIT
19	1466330000	1	PLUNGER M10 W/CABLE KIT
20	146 2452 000	2	Halterung
21	146 2448 000	2	SPACER 12.2X24X4
22	146 2447 000	2	WASHER 14X36X2.5 UNI6593
23	146 2450 000	2	Zugstange
25	145 9679 000	2	Mikroschalter 16A 250V
26	146 2501 000	2	SCREW M4X50 HEX HD F/THD SS ISO4017
27	146 2456 000	2	BELLOWS RUBBER
28	146 2458 000	1	Hebel
29	1463804000	1	Hebel, rechts
30	146 2453 000	2	Griff
31	146 2717 000	1	COVER FRONT
32	33003964	4	Schraube M5x25
33	146 2106 000	1	Lenkrad D. 320
34	146 2457 000	1	BELLOW RUBBER
35	33005603	4	Mutter
36	145 8753 000	1	Kappe
37	909 5011 000	3	Schraube M6X20 UNI7687 SS
38	146 2023 000	1	Mutter M20/M18
39	146 2455 000	2	Mutter, HEX M 14
40	145 4540 000	1	Sicherungsring M10
41	33005505	2	NUT HEX M10 UNI5588
42	L08300000	1	WASHER 8X24 UNI6592
43	33005913	2	WASHER M6 UNI6592
45	145 0498 000	2	Schraube

POSITION 44 NO MORE AVAILABLE AS SINGLE SPARE BUT INCLUDED IN POSITION 19

LENKSYSTEM

FLOORTEC R 570 B

13-04-2015

ET-Liste-Nr.
R570B16

23

Pos	Artikelnr.	Me	Beschreibung
46	145 0521 000	1	Schraube M8x16
47	145 1252 000	2	Distanzstück ø6,5 x ø10 x 4,5
48	33005915	4	Unterlagsscheibe 8x16
49	145 9666 000	1	Gabelkopf M10
50	146 0250 000	1	WASHER 6,4X16,3X1 UNI1739
51	145 9769 000	2	Kugelgelenk M10
52	146 2466 000	1	Hebel
53	146 2505 000	1	Hauptgrundplatte
54	146 2467 000	1	LEVER MAIN BROOM
55	146 2468 000	1	Gewindestange M10 x 410
56	1463963000	1	Schwenkhebel
58	33005502	1	Nuss M6
59	33005604	1	Mutter selbstsichernd M6 UNI7474
60	146 1646 000	1	Relais 24V
61	1463803000	1	Hebel links

Front wheel

FLOORTEC R 570 B

13-04-2015

ET-Liste-Nr. R570B18

25

Pos	Artikelnr.	Me	Beschreibung
1	146 0960 000	1	Lenkwelle
2	33005505	2	NUT HEX M10 UNI5588
3	33005843	4	Dichtungsring M10
4	33004387	4	SCREW M10X25 CAP HD HEX SOCK ISO4762
5	145 1747 000	1	Radbremse v orne
6	33004013	1	Schraube M10 x 45
7	145 4504 000	1	Scheibe 20x43x3
8	33005842	15	U-Scheibe
9	33023206	1	SCREW M8X20 C/SUNK ISO10642 10 PCS SET
10	33003814	1	SCREW M10X65 HEX HD P/THD ISO4014
11	145 8296 000	1	U-Scheibe
12	33005445	3	Schraube M8x25
13	33005915	9	Unterlagsscheibe 8x16
14	33006056	1	Ring D17
15	33003996	8	Schraube M8 x 30
16	33005916	4	Unterlagscheibe M10 UNI6592
17	33005620	1	NUT SELF L. M20 UNI7474
18	145 2357 000	2	Kugellager 6207-2RS
19	146 2442 000	1	Rad v orne weich
19	146 2745 000	1	Rad nicht abrieb fest
20	146 2438 000	1	SPACER
21	146 2437 000	1	Stützrad v orne
22	146 2441 000	1	Bremsklotz
23	146 2440 000	1	Bolzen f. Vorderrad
24	146 2439 000	1	PLATE SUPPORT STEERING
25	146 2443 000	1	Kette 3/8 - 73
26	146 2444 000	1	Kabelklammer
27	145 2585 000	1	WASHER
28	145 2714 000	1	Zahnkranz
29	33004364	4	Schraube, M8x16 UNI5931
30	145 2587 000	1	FLANGE
31	33004326	2	Schraube M5 X12
32	145 2586 000	1	FLANGE
33	145 9505 000	1	Buchse bbb 17x25x25

Pedal

FLOORTEC R 570 B

13-04-2015

ET-Liste-Nr. R570B20

26

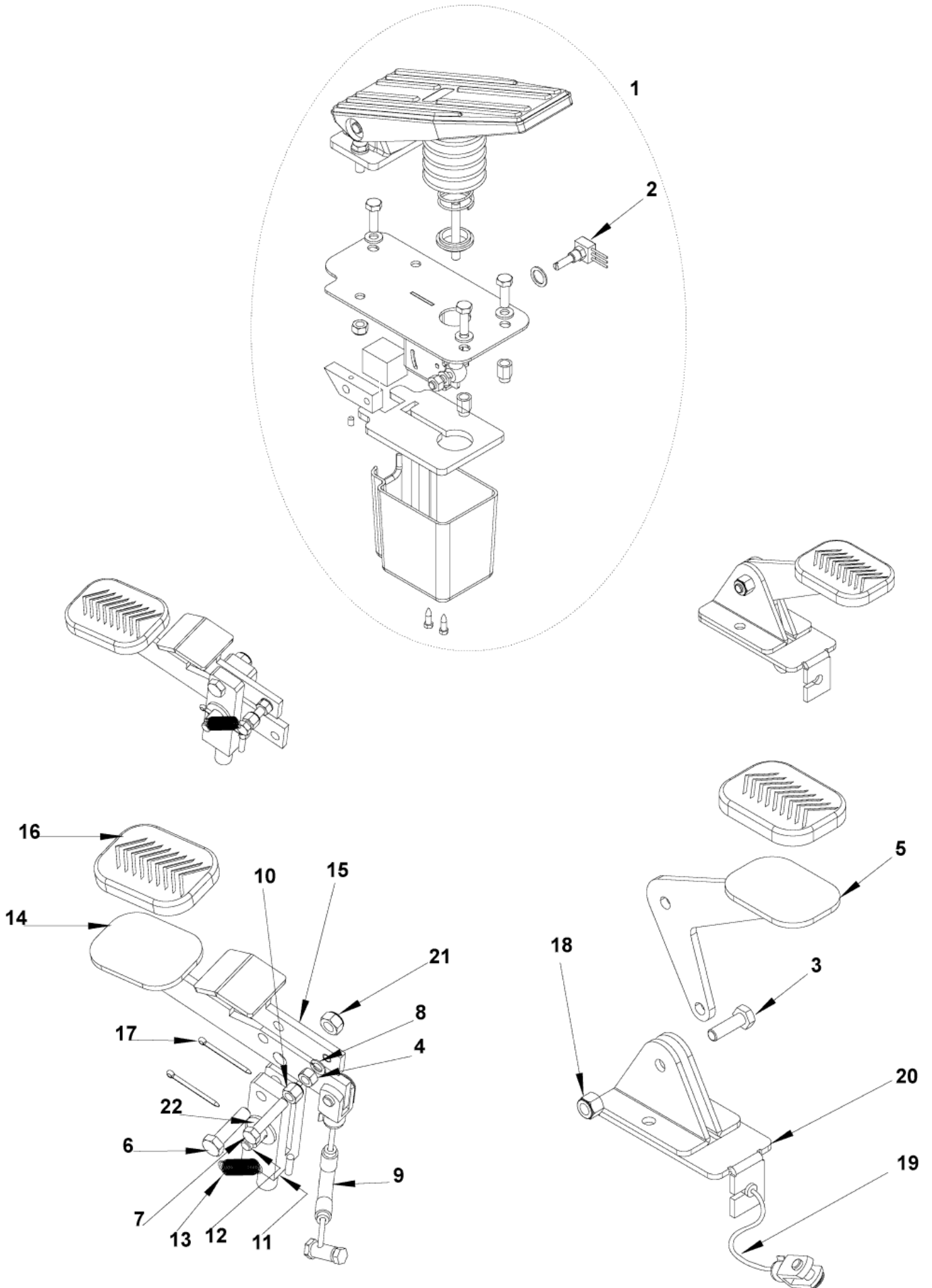

Pedal

FLOORTEC R 570 B

13-04-2015

ET-Liste-Nr.
R570B20

27

Pos	Artikelnr.	Me	Beschreibung
1	146 2542 000	1	PEDAL SPEED CONTROL KIT
2	146 2606 000	1	Potentiometer
3	33003975	1	Schraube M6x20
4	33005691	1	Mutter M5
5	145 1841 000	1	PEDAL SKIRT RAIS.DEVICE
6	33003976	1	Schraube M6x25
7	33003964	1	Schraube M5x25
8	33005839	1	U-Scheibe M5
9	146 2463 000	1	CABLE BRAKE
10	33005603	1	Mutter
11	145 2540 000	1	Pedalhalter
12	145 2541 000	1	Achsbolzen für Fußpedal
13	145 9290 000	1	Feder
14	145 3472 000	1	PEDAL
15	145 3490 000	1	PEDAL BRAKE
16	145 8478 000	2	Pedalauflage Gummi
17	33005756	2	PIN SPLIT 2X25 UNI1336
18	33005562	1	Mutter M6
19	146 2477 000	1	Kabelschürze
20	145 1839 000	1	Klappe
21	33005562	1	Mutter M6
22	33005915	2	Unterlagsscheibe 8x16

Bedienfeld

FLOORTEC R 570 B

13-04-2015

ET-Liste-Nr. R570B22

28

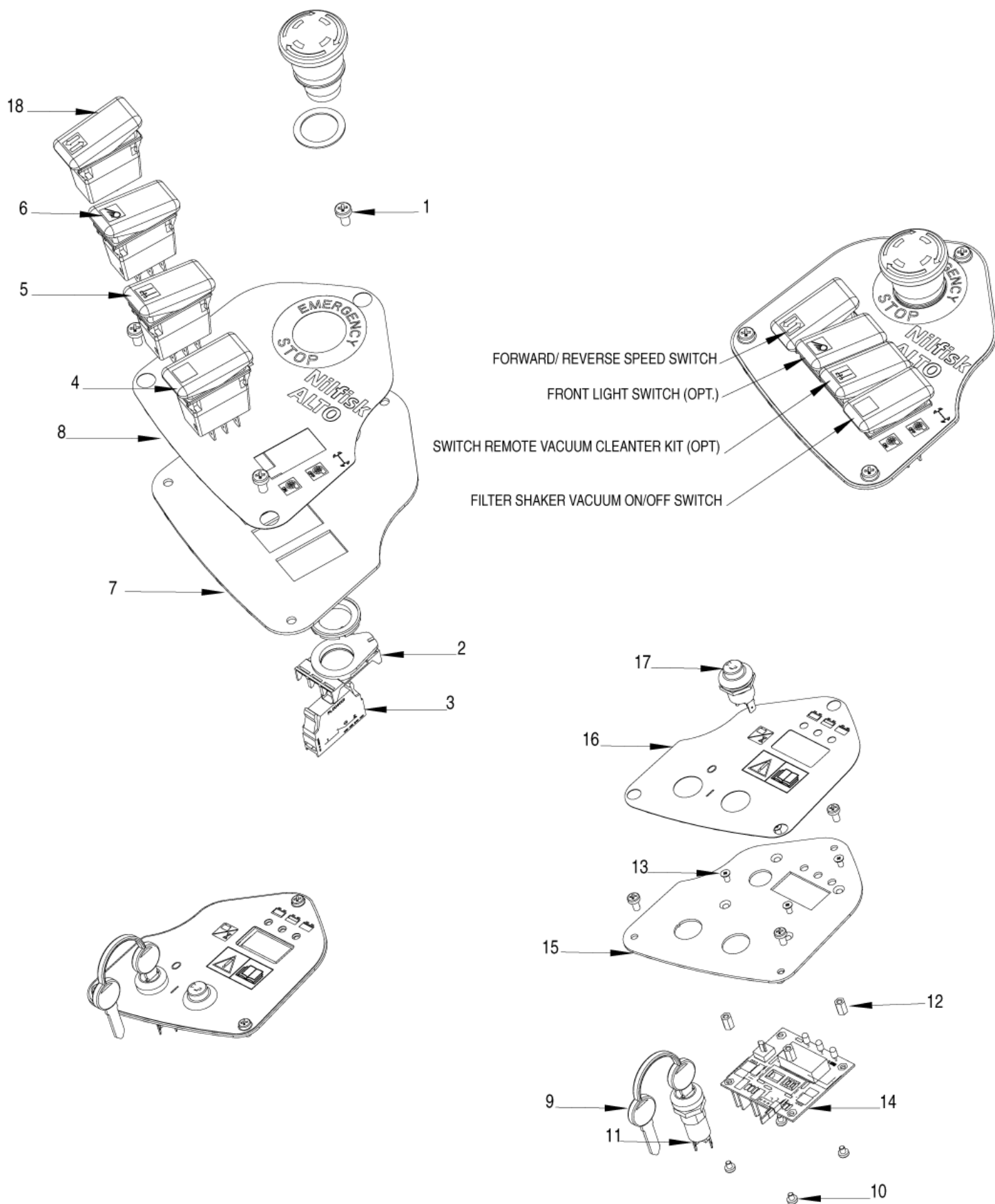

Bedienfeld

FLOORTEC R 570 B

13-04-2015

ET-Liste-Nr. R570BZZ

29

Pos	Artikelnr.	Me	Beschreibung
0	146 2719 000	1	HARNESS CONTROL PANEL
1	L08603041	6	Linsenschraube M5x10
2	146 1727 000	1	NOT - SCHALTER
3	146 1728 000	1	CONTACT, NC.
4	146 2532 000	1	SWITCH
5	146 1973 000	1	SWITCH
6	146 1974 000	1	Schalter
7	146 2460 000	1	Bedienfeld links
8	146 2701 000	1	Klebesch. Bedienfeld links
9	146 2887 000	1	KEY (2 PCS)
10	L08812094	4	SCREW M4X5 PAN HD PHIL ISO7045
11	146 2888 000	1	Schlüsselschalter
12	146 0657 000	4	SPACER
13	146 0658 000	4	Schraube M4 x 8
14	1466161000	1	CONTROLLER MAIN MACHINE KIT INST. INSTR. 1465914000
15	146 2459 000	1	Bedienfeld, rechts
16	146 2700 000	1	DECAL CONTROL PANEL RT
17	145 9678 000	1	Taster
18	146 2608 000	1	Fahrrichtungsumschalter

ANTRIEBSSYSTEM

FLOORTEC R 570 B

13-04-2015

ET-Liste-Nr.
R570B24

30

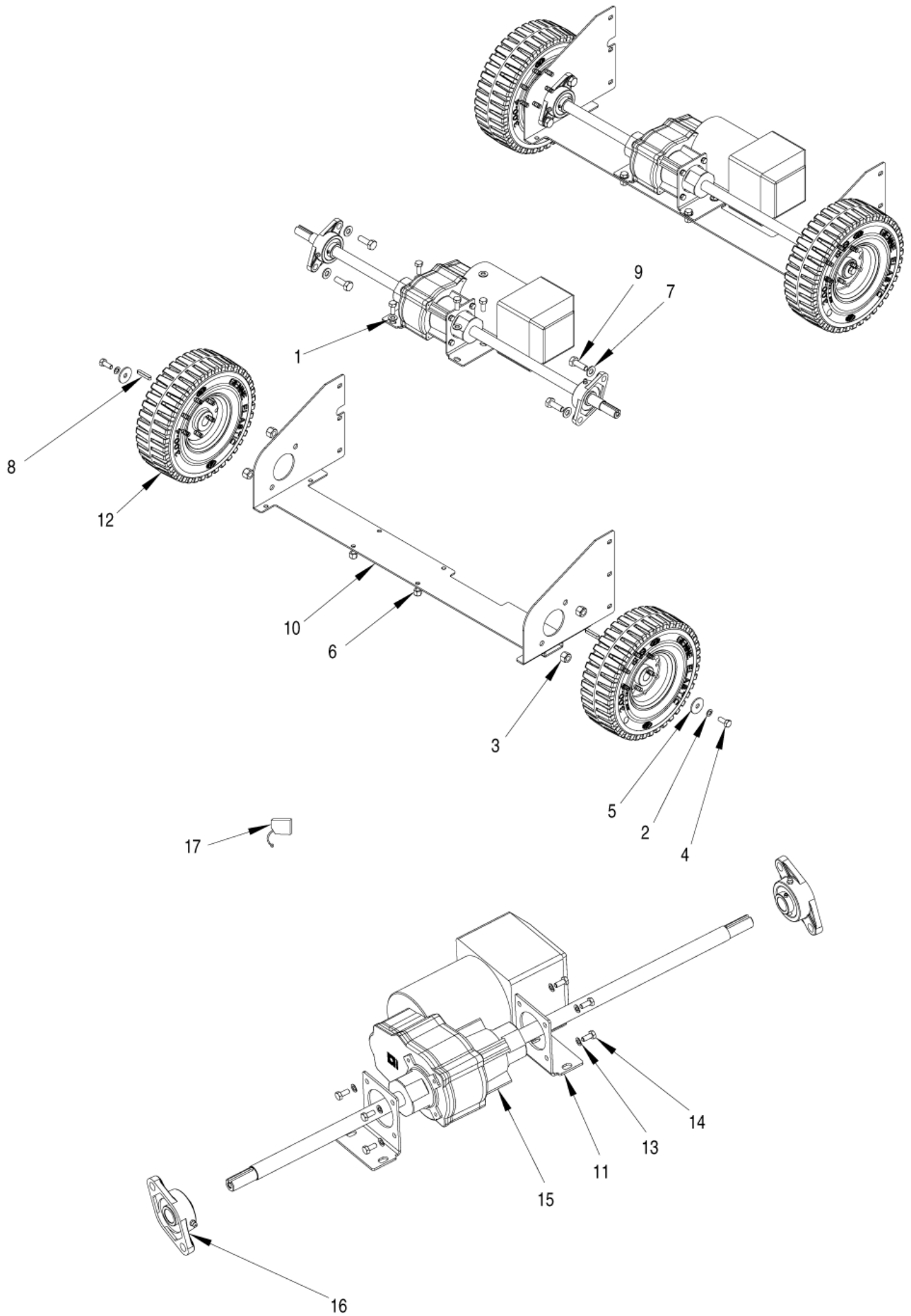

ANTRIEBSSYSTEM

FLOORTEC R 570 B

13-04-2015

ET-Liste-Nr. R570B24

31

Pos	Artikelnr.	Me	Beschreibung	
0	1463231000	1	Getriebemotorkit	F. BATTERY MACH. BEFORE 071510157
0	1463232000	1	Reduziergetriebemotor	F. PETROL MACH. BEFORE 071510157
1	33005915	4	Unterlagsscheibe 8x16	
2	33005842	2	U-Scheibe	
3	33005566	4	Selbstsperrende MutterM10	
4	33005444	6	Schraube M8x20 verzinkt	
5	145 9171 000	2	Scheibe 8 x 24	
6	33005565	4	Selbstsichernde Mutter M8	
7	33005916	4	Unterlagscheibe M10 UNI6592	
8	145 9776 000	2	Passfeder 6 x 6 x 35	
9	33004010	4	Schraube	
10	146 2704 000	1	BRIDGE REAR WHEELS	
11	146 2435 000	2	Winkel	
12	146 2433 000	2	Rad hinten weich	
12	146 2746 000	2	Rad nicht abf ärbend	
13	33005851	8	Unterlegscheibe	
14	146 2126 000	8	Schraube HEX HD M6x14	
15	1463228000	1	Motor Fahrtrieb kpl.	TSB_IT 2007_010 R570 Reduction gear motor
16	146 2436 000	2	Kugellager mit Flansch	
17	L08603949	1	Kohlebürste SET STÜCK	

Dust control

FLOORTEC R 570 B

13-04-2015

ET-Liste-Nr.

R570B26

32

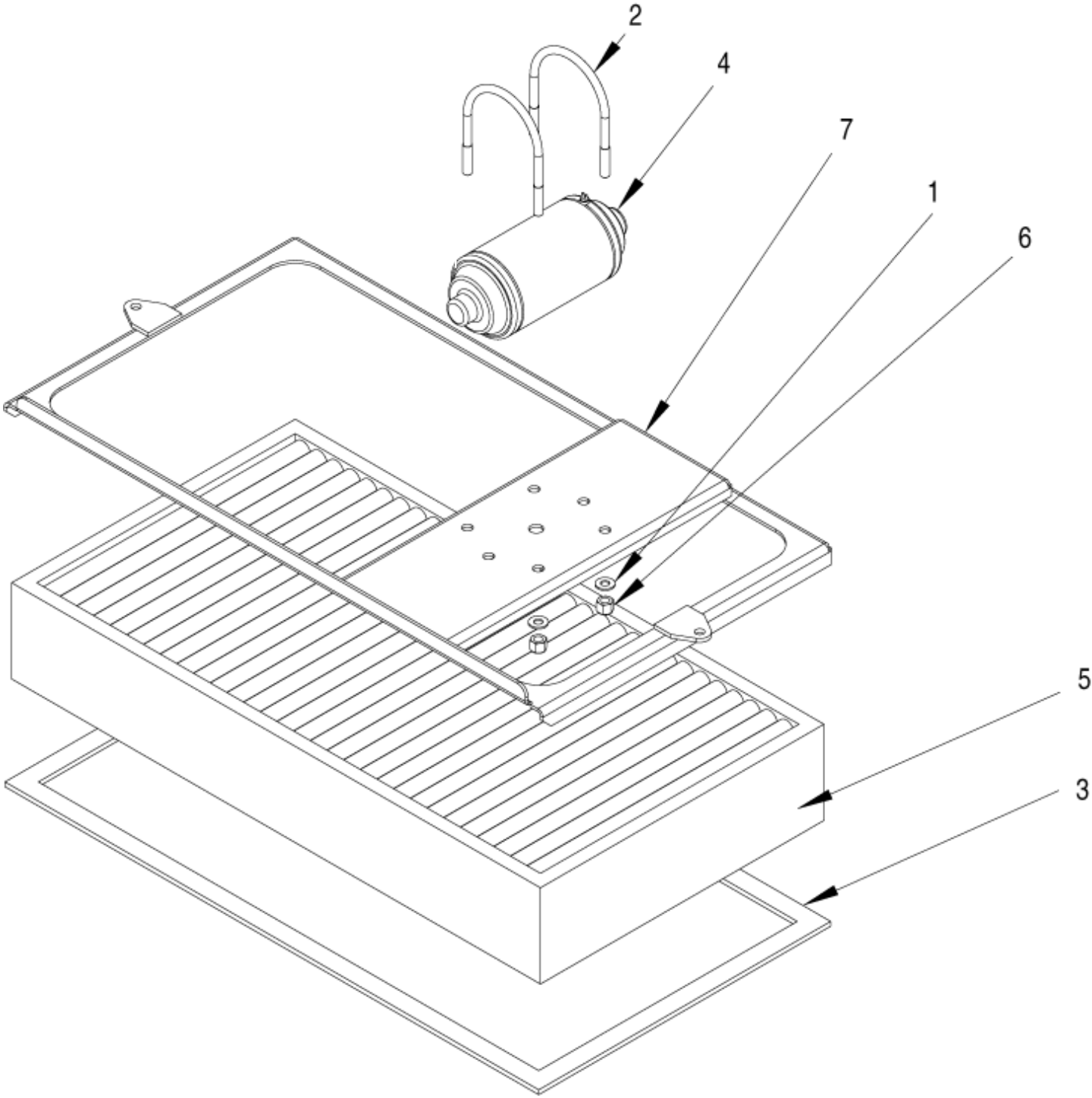

Dust control

FLOORTEC R 570 B

13-04-2015

ET-Liste-Nr.
R570B26

33

Pos	Artikelnr.	Me	Beschreibung
0	146 2731 000	1	Vorfilter
1	33005915	4	Unterlagsscheibe 8x16
2	1465997000	2	COLLAR METAL U M8 PKD
3	146 2729 000	1	GASKETS KIT
4	146 2795 000	1	MOTOR,FILTER SHAKER KIT
5	145 6013 000	1	Filter Polyester
5	146 2759 000	1	Filter PE
5	1463523000	1	Papierfilter
6	33005565	4	Selbstsichernde Mutter M8
7	146 2428 000	1	Rahmen Filterrüttlermotor

ABFALLBEHÄLTER

FLOORTEC R 570 B

13-04-2015

ET-Liste-Nr.
R570B28

34

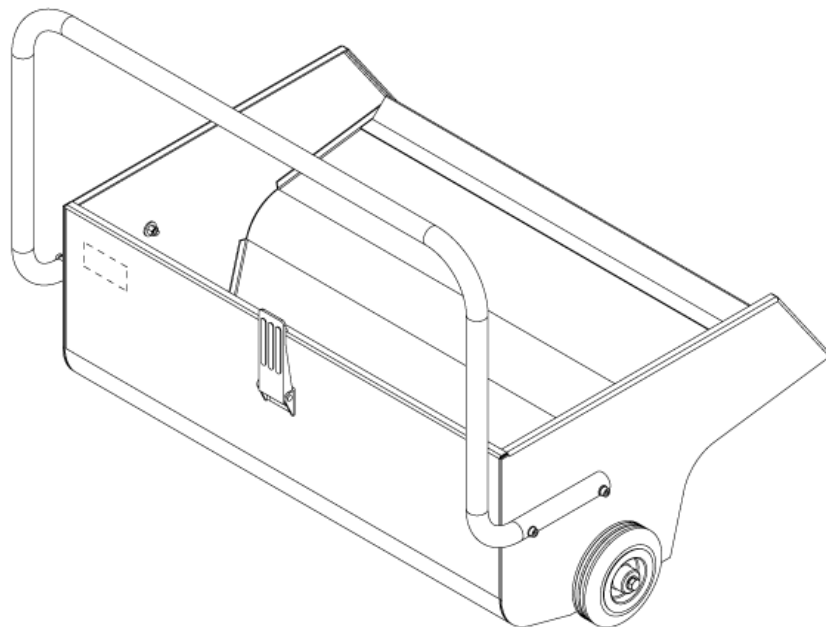
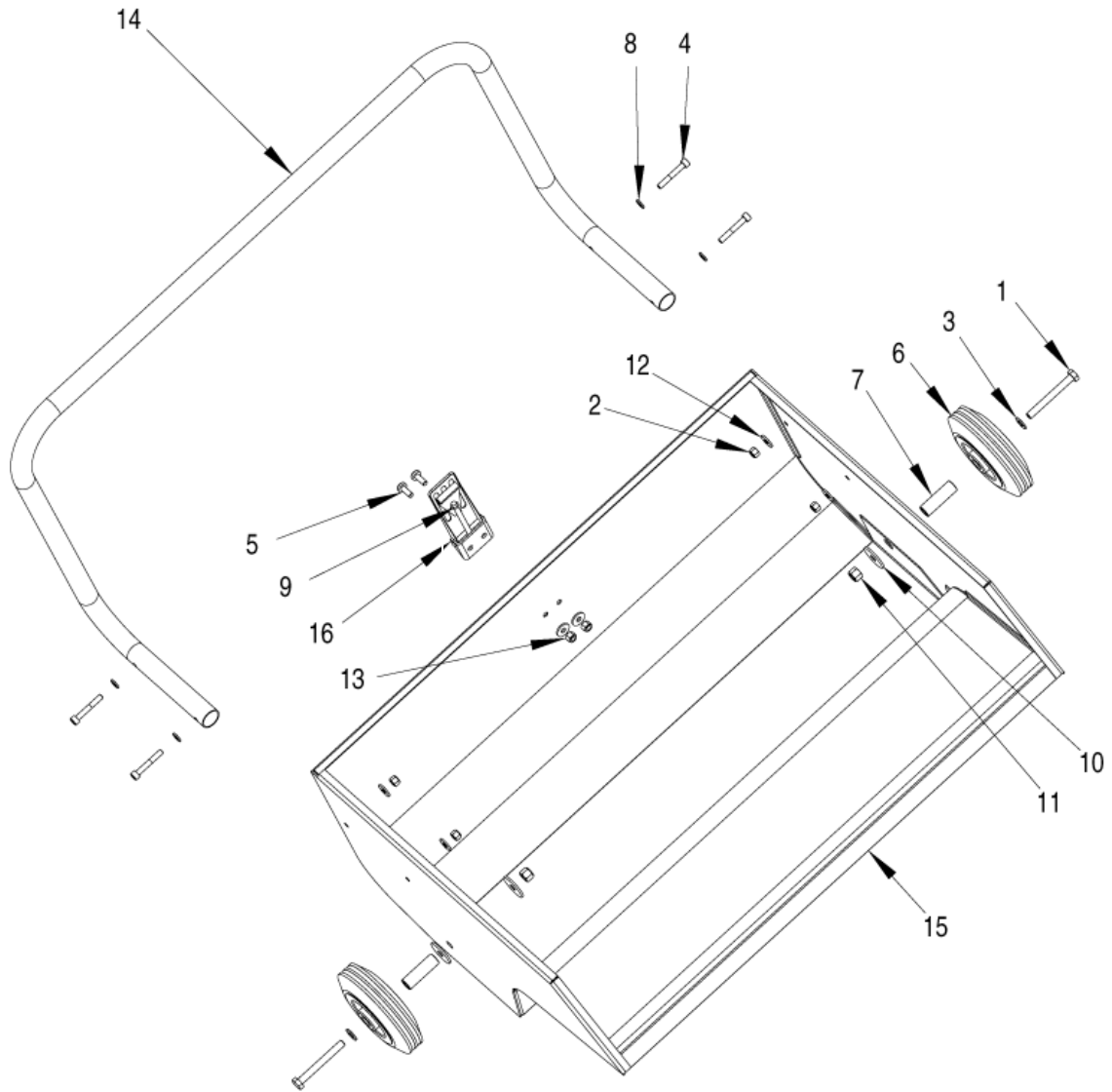

ABFALLBEHÄLTER

FLOORTEC R 570 B

13-04-2015

ET-Liste-Nr.
R570B2B

35

Pos	Artikelnr.	Me	Beschreibung
0	146 2699 000	1	Behälter Mini Set
1	33004004	2	SCREW M8X70 HEX HD F/THD ISO4017
2	33005562	4	Mutter M6
3	33005915	2	Unterlagsscheibe 8x16
4	33004350	4	SCREW M6X40 CAP HD HEX SOCK ISO4762
5	L08812095	2	Schraube M6x16
6	145 5116 000	2	Rad
7	145 5118 000	2	Buchse
8	33005913	4	WASHER M6 UNI6592
9	33005502	1	Nuss M6
10	145 9171 000	4	Scheibe 8 x 24
11	33005565	2	Selbstsichernde Mutter M8
12	L08228600	6	Dichtscheibe 6X18 UNI6592
13	L08603682	2	NUT SELF L. M6 UNI7474
14	146 2706 000	1	HANDLE DIRT CONTAINER
15	146 2707 000	1	Schmutzbehälter
16	145 9330 000	1	Haken

Elektrokomponenten

FLOORTEC R 570 B

13-04-2015

ET-Liste-Nr. R570B30

36

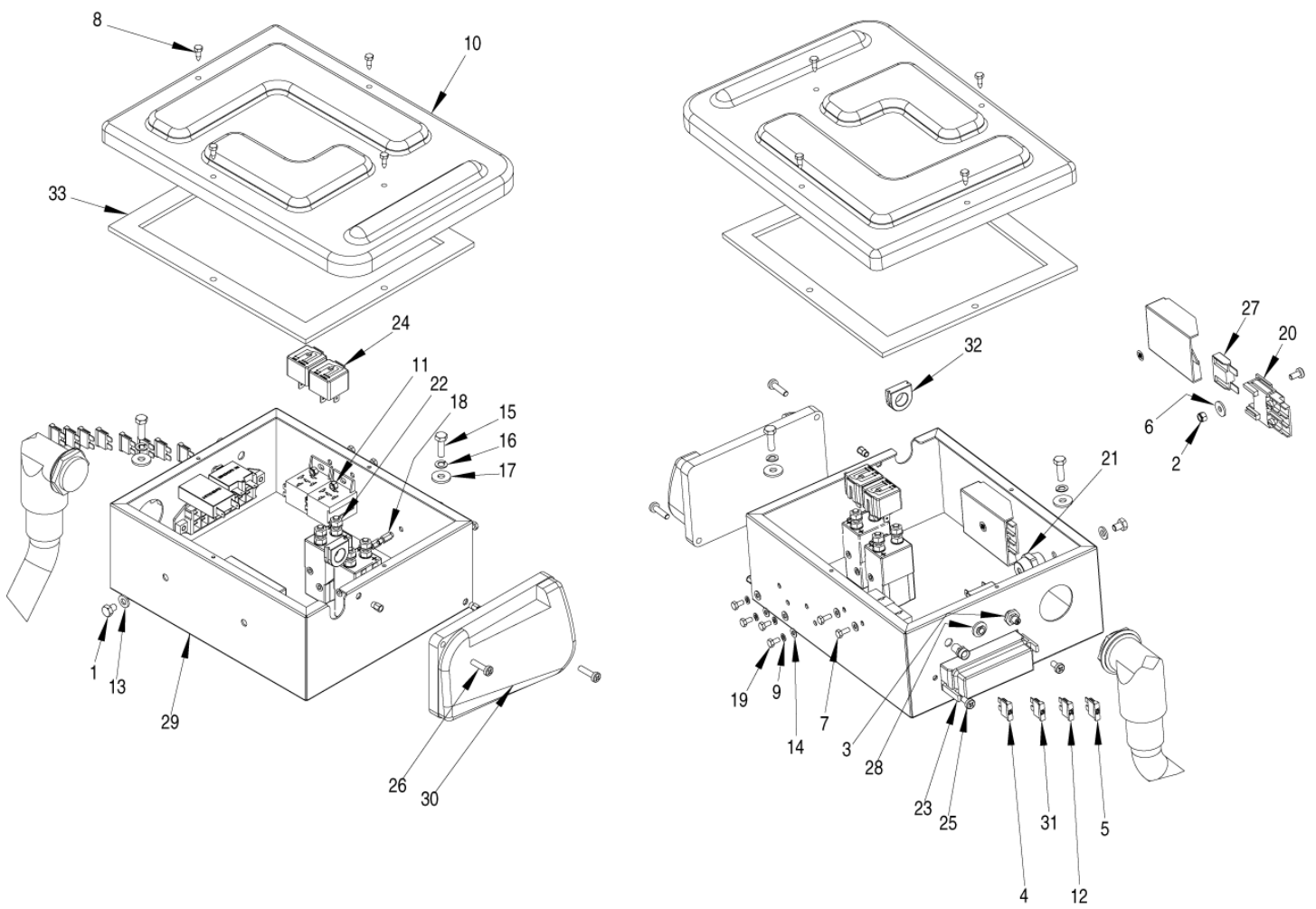

Elektrokomponenten

FLOORTEC R 570 B

13-04-2015

ET-Liste-Nr. R570B30

37

Pos	Artikelnr.	Me	Beschreibung	
0	146 1986 000	1	CONNECTOR 120A	
0	146 2492 000	1	Kabelbaum	
0	1463229000	1	Kabelbaumkit	TSB_IT 2007_010 R570 Reduction gear motor
1	33003970	1	SCREW M6X8 HEX HD F/THD ISO4017	
2	33005603	1	Mutter	
3	L08812633	1	Sicherungsautomat 10 Azu SR 100 SB	
5	145 0227 000	1	Sicherung 40A	
6	145 1261 000	1	U-Scheibe	
7	33003947	2	SCREW M4X10 HEX HD F/THD ISO4017	
8	145 4498 000	4	Schraube TE 4,2x9,5	
9	33005838	4	WASHER M4 UNI1751B	
0A	146 2490 000	1	HARNESS ELECTRONIC BOX	before S/N 070503310
0B	1463157000	1	GROMMET D.15X22	starting from S/N 070503311
0B	1463180000	1	HARNESS ELECTRONIC BOX	starting from S/N 070503311
10	146 2484 000	1	Deckel Elektronikkasten	
11	145 5743 000	2	NUT SELF L. M4 UNI7474	
12	145 8514 000	2	Sicherung 25A	
13	33005913	1	WASHER M6 UNI6592	
14	33005911	6	U-Scheibe	
15	33003975	2	Schraube M6x20	
16	33005851	2	Unterlegscheibe	
17	L08228600	2	Dichtscheibe 6X18 UNI6592	
18	146 0627 000	2	Distanzstück	
19	146 0632 000	2	Schraube	
20	146 0659 000	1	Sicherungshalter	
21	146 0708 000	1	Isolator weiß	
22	146 0719 000	1	Schalter 24V elektromagnetisch	
23	146 1170 000	1	Sicherungshalter 8x	
24	145 3712 000	2	Relais 24V	
25	146 1710 000	3	Schraube M5x10	
26	146 2530 000	2	SCREW M4X20 PAN HD PHIL ISO7045	
27	146 2486 000	1	Sicherung 70A	
28	909 5706 000	1	Sicherung 30A	
30	146 2718 000	1	Karte Steuerelektronik	
31	145 9853 000	2	Sicherung 15A	
32	146 2485 000	2	GROMMET	
33	146 2802 000	1	Dichtung f.	
4A	146 0068 00	3	Sicherung 10A	before S/N 070503310
4B	145 8513 000	1	Sicherung 30A	starting from S/N 070503311
4B	146 0068 00	2	Sicherung 10A	starting from S/N 070503311
29A	146 2705 000	1	BOX ELECTRIC COMPONENTS	before S/N 070503310
29B	1463156000	1	BOX ELECTRIC COMPONENTS	starting from S/N 070503311

Batterieladegerät

FLOORTEC R 570 B

13-04-2015

ET-Liste-Nr. R570B32

38

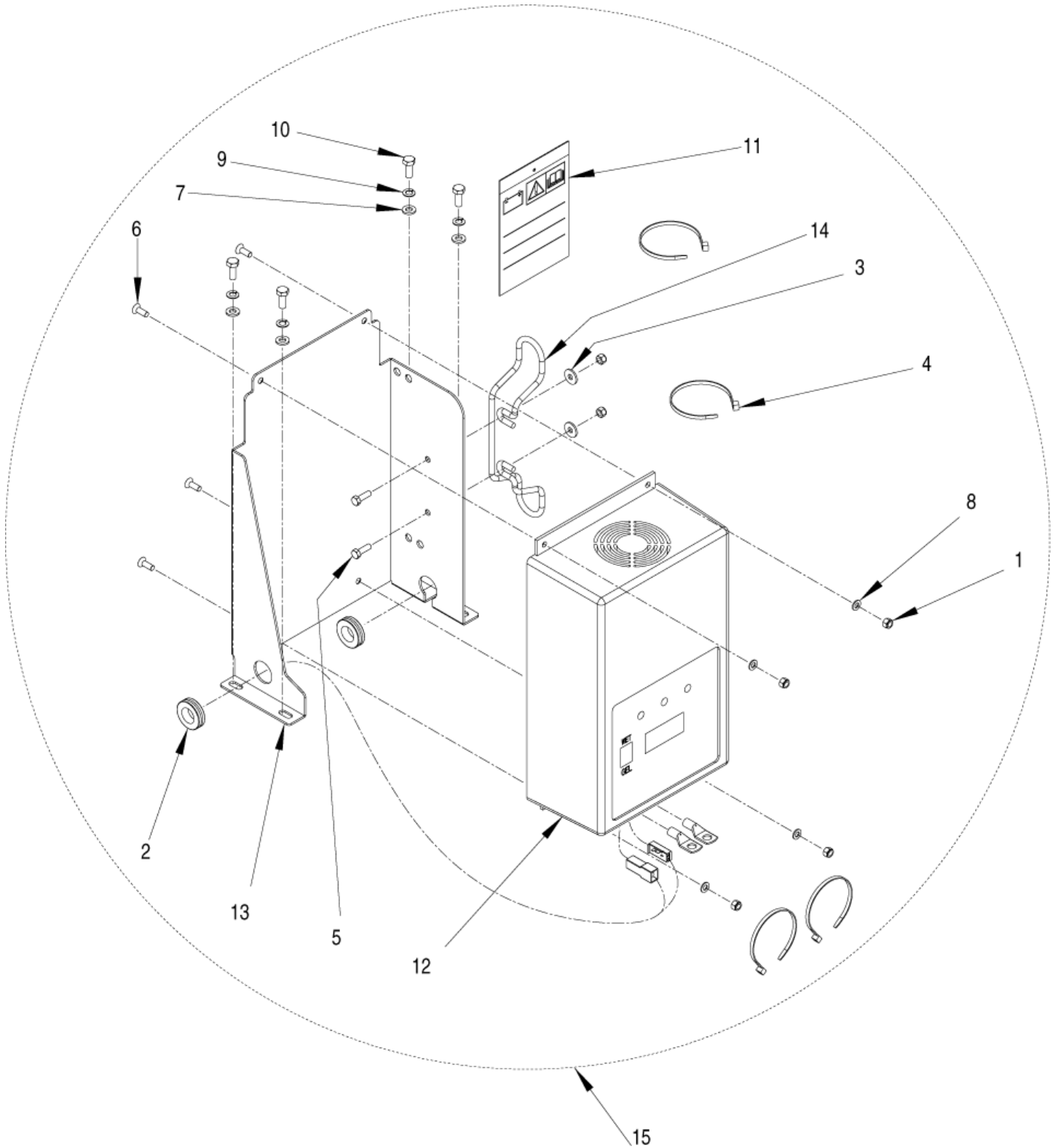

Batterieladegerät

FLOORTEC R 570 B

13-04-2015

ET-Liste-Nr. R570B32

39

Pos	Artikelnr.	Me	Beschreibung
0	145 1726 000	1	FUSE 10A
0	146 0801 000	1	SWITCH WET/GEL
0	146 2139 000	1	CARD ELECTRONIC BATTERY CHARGER
0	146 2142 000	1	Lüfter für Kühlung
0	146 2144 000	1	Kabel
0	1466172000	1	CONTROLLER DISPLAY PKD
1	33005603	6	Mutter
2	145 1237 000	2	Kabelführung ø22
3	145 1261 000	2	U-Scheibe
4	145 1449 000	4	TIE CABLE 3.6x140 BLACK
5	33003962	2	Schraube M5x16
6	33004562	4	Schraube M5 x 14
7	33005913	4	WASHER M6 UNI6592
8	33005912	4	Unterlegscheibe M5
9	33005851	4	Unterlegscheibe
10	33003974	4	Schraube M6X16 UNI5739
11	146 0803 000	1	CARD INSTRUCTION.BAT.CHAR
12	146 2131 000	1	Batterie Ladegerät 230 V
13	146 2311 000	1	BRACKET
14	1466317000	1	SUPPORT CABLE KIT
15	146 2052 000	1	Batterieladegerät KIT

INST.INSTR. 146 2055 000

Zubehör 2

FLOORTEC R 570 B

13-04-2015

ET-Liste-Nr. R570B36

40

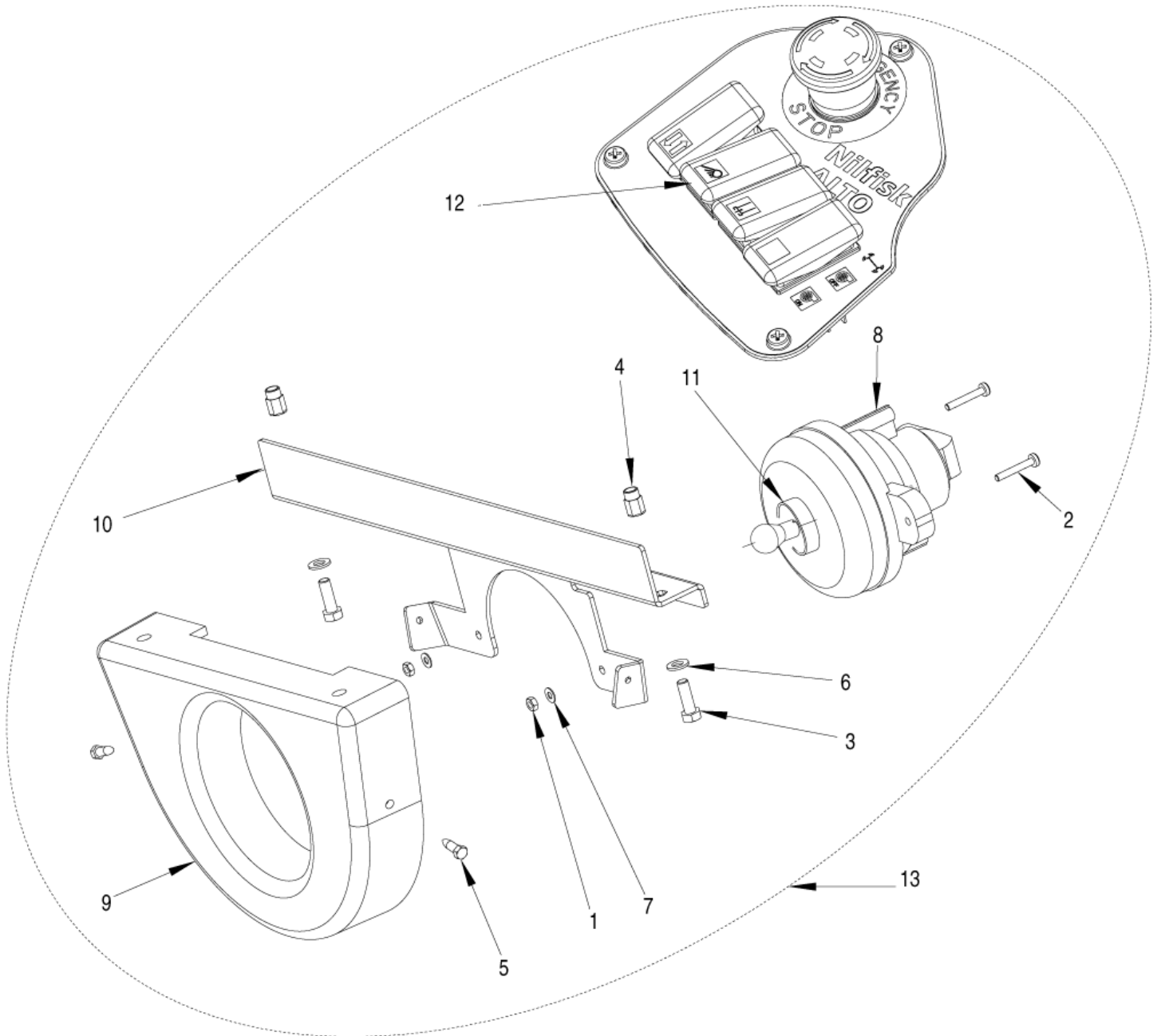

Zubehör 2

FLOORTEC R 570 B

13-04-2015

ET-Liste-Nr.
R570B36

41

Pos	Artikelnr.	Me	Beschreibung
0	146 0068 00	1	Sicherung 10A
1	33005499	2	Mutter HEX M3
2	L08603897	2	SCREW M3X20 PAN HD PHIL ISO7045
3	33003961	2	Schraube M5x14
4	145 4771 000	2	Schraube M5
5	145 5867 000	2	Screw 3,9x13 ISO 1479
6	33005912	2	Unterlegscheibe M5
7	33005910	2	U-Scheibe M3
8	146 1985 000	1	Licht
9	146 2528 000	1	Scheinwerferblende
10	146 2527 000	1	PLATE. LIGHT SUPPORT
11	145 5518 000	1	Lampe 24V/21W
12	146 1974 000	1	Schalter
13	146 2785 000	1	Arbeitsleuchte Set

OPTION - INST.INSTR.146 2786 000

Zubehör 3

FLOORTEC R 570 B

13-04-2015

ET-Liste-Nr.
R570B38

42

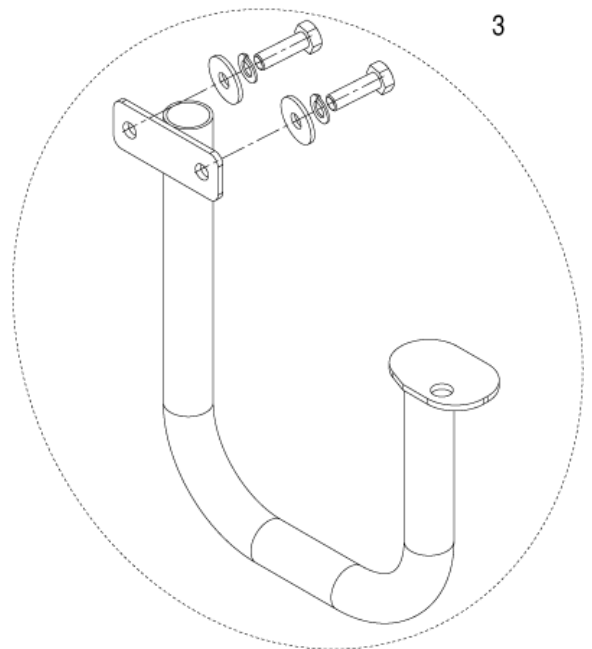
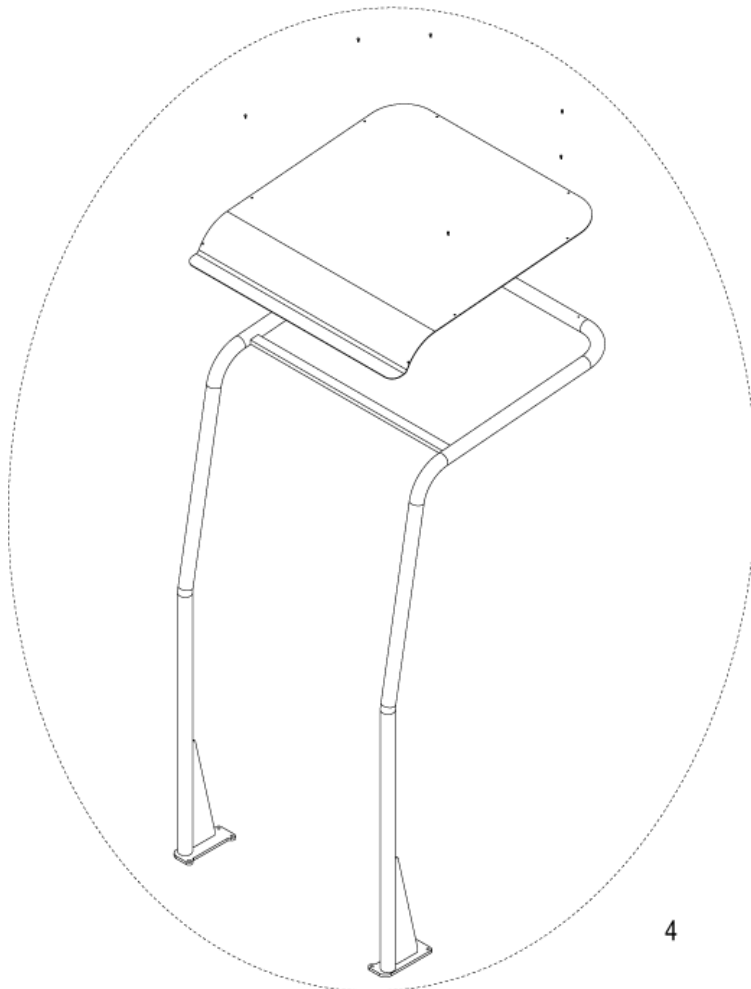
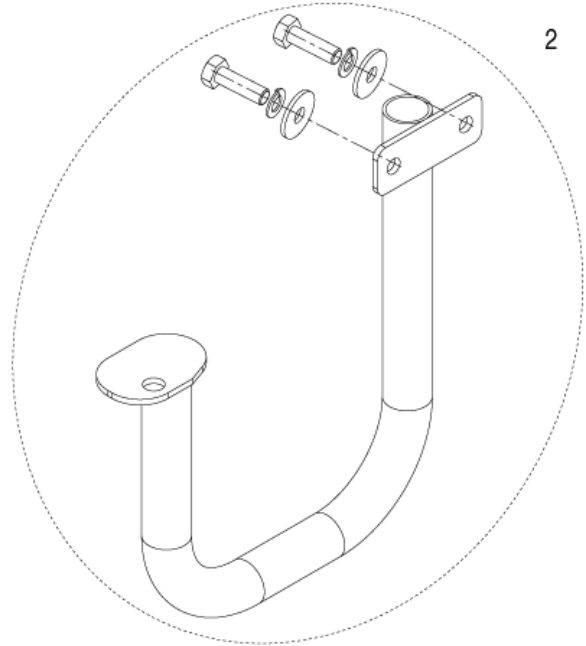
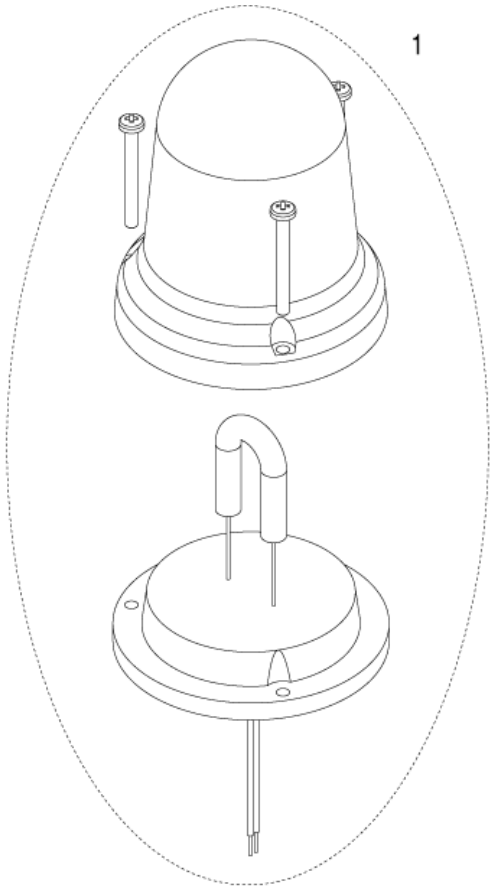

Zubehör 3

FLOORTEC R 570 B

13-04-2015

ET-Liste-Nr. R570B3B

43

Pos	Artikelnr.	Me	Beschreibung	
0	145 3738 000	1	PLUG CYL. 0.25/1	
1	146 2692 000	1	Warnlicht Kit	OPTION - INST.INSTR.146 2693 000
2	146 2736 000	1	Seitenbesenanfahrerschutz RSR 1100 S	OPTION - INST.INSTR.146 2698 000
3	146 2737 000	1	Seitenbesenanfahrerschutz LSR 1100 S	OPTION - INST.INSTR.146 2698 000
4	146 2735 000	1	Fahrerschutzdach f.	OPTION - INST.INSTR.146 2738 000