

03/C3KSA-1

03/C3KSA-2

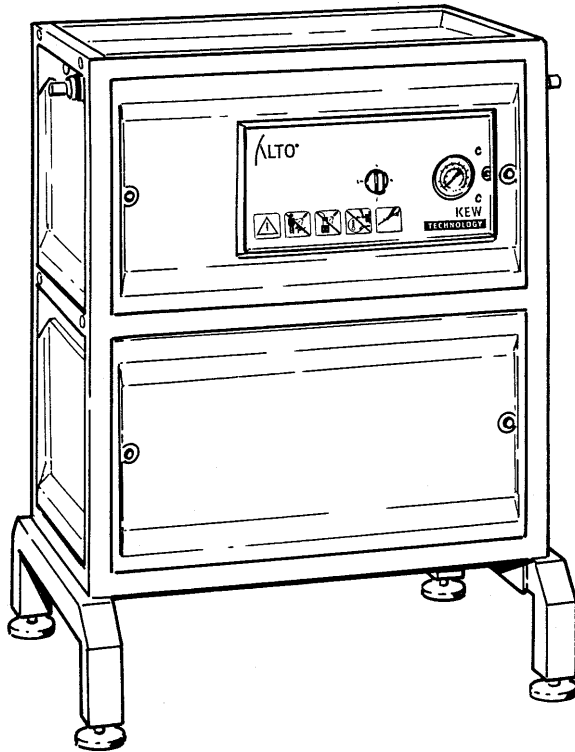
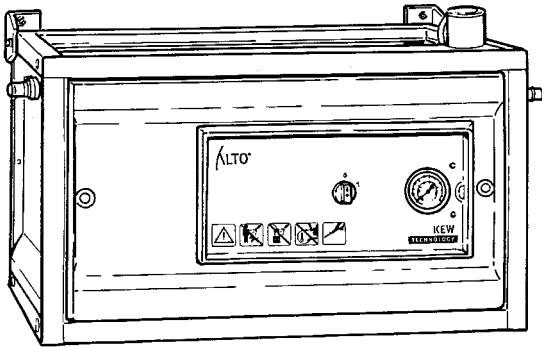

ALTO®

**Total Cleaning
Confidence™**

Reservedele
Spare parts
Ersatzteile
Pièces détachées

Maskine, monteret / Machine, monté / Maschine, montiert / Appareil, monté

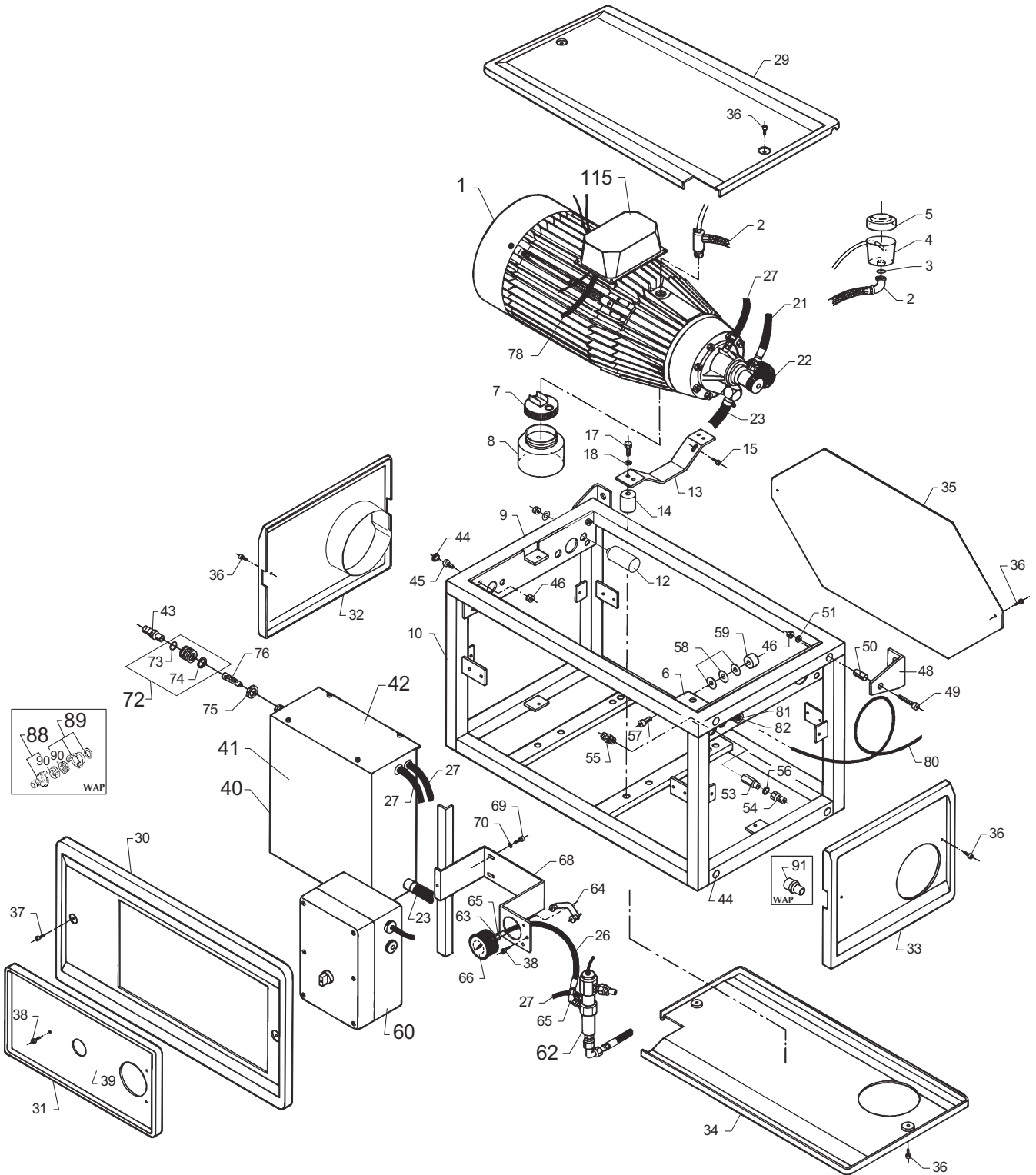

Pos. Ref.	Nr. No.	Betegnelse Bezeichnung	Designation Désignation	KSA-1	KSA-2
-	-	Maskine, monteret Machine, mounted Maschine, montiert Appareil, monté	KSA-1	x	
1	-	Motorpumpeenhed Motor/pump unit Motorpumpenkörper Unité moto-pompe	Se side 10 See page 10 Siehe Seite 10 Voir page 10	x	
2	6300061	Olieslange Oil hose Ölschlauch Durite à fuel		1	
3	3000320	O-ring O-ring O-Ring Joint torique		1	
4	6300392	Olieglas Oil reservoir Ölglas Réservoir huile usée		1	
5	2201854	Låg f. olieglas Cover f. oil reservoir Deckel für Ölglas Couvercle réservoir à huile		1	
6	6300326	Beslag f. olieglas Retainer for oil reservoir Ölglashalter Support réservoir à huile		1	
-	6301261	Beslag f. olieglas, RF Retainer for oil reservoir, SS Ölglashalter, RF Support réservoir à huile, INOX		1	
7	6101625	Låg f. slamglas mont. Cover f. sludge container, mounted Deckel f. Schlammglas mont. Couvercle réservoir à huile, mont.		1	
8	2200467	Slamglas Sludge container Schlammglas Réservoir à huile usée		1	
9	6300102	Overramme Top frame Oberrahmen Châssis supérieure		1	
-	6300126	Overramme, RF Top frame, SS Oberrahmen, RF Châssis supérieure, INOX		1	
10	6300101	Modulramme Module frame Modulrahmen Châssis de module		1	
-	6300125	Modulramme, RF Module frame, SS Modulrahmen, RF Châssis de module, INOX		1	
13	6304330	Pumpekonsol Pump bracket Pumpenkonsole Console de pompe		2	
14	1803048	Svingningsdæmper Vibration damper Schwingungsdämpfer Amortisseur de vibration		4	
15	1802651	Taptite skrue Taptite screw M10x20 Taptite-Schraube Vis Taptite		4	
17	1800788	Skrue Screw M8x12 Schraube Vis		8	
-	1800788	Skrue, RF Screw, SS M8x12 Schraube, RF Vis, INOX		8	

Pos. Ref.	Nr. No.	Betegnelse Bezeichnung	Designation Désignation	KSA-1	KSA-2
18	1801398	Skive Washer Scheibe Rondelle		8	
-	1810274	Skive, RF Washer, SS Scheibe, RF Rondelle, INOX		8	
21	6300109	Afgangsslange m. vinkel Hose w. elbow Schlauch m. Winkel Flexible a. coude		1	
22	6400083	Svingningsdæmper mont. Vibration damper mounted Schwingungsdämpfer mont. Amortisseur de vibration mont.		1	
23	5206230	Slange Hose Schlauch Flexible	(L=440)	1	
26	6300206	Manometerslange Hose f. pressure gauge Schlauch f. Manometer Flexible pour manomètre		1	
27	5206298	Slange Hose Schlauch Flexible	(L=1000)	2	
29	6304401	Topplade Top cover Abdeckplatte, oben Plaque en dessus		1	
30	6304400	Frontplade Front cover Abdeckplatte, vorne Plaque avant		1	
31	6304321	Instrumentplade Control panel Armaturenbrett Tableau de bord		1	
32	6304397	Endeplade Side cover Seitenplatte Plaque de côté		1	
33	6304402	Endeplade Side cover Seitenplatte Plaque de côté		1	
34	6304404	Bundplade Bottom cover Bodenplatte Semelle		1	
35	6300340	Bagplade Rear cover, Abdeckplatte, hinten Plaque arrière		1	
36	1803030	Skrue Screw M5x12 Schraube Vis		10	
-	1804475	Skrue, RF Screw, SS M5x12 Schraube, RF Vis, INOX		10	
37	1803055	Fingerskrue Thumb screw Knebelschraube Vis de blocage		2	
38	1801406	Skrue Screw Schraube Vis		3	
-	1804475	Skrue, RF Screw, SS Schraube, RF Vis, INOX		3	

Maskine, monteret / Machine, mount / Maschine, montiert / Appareil, monté

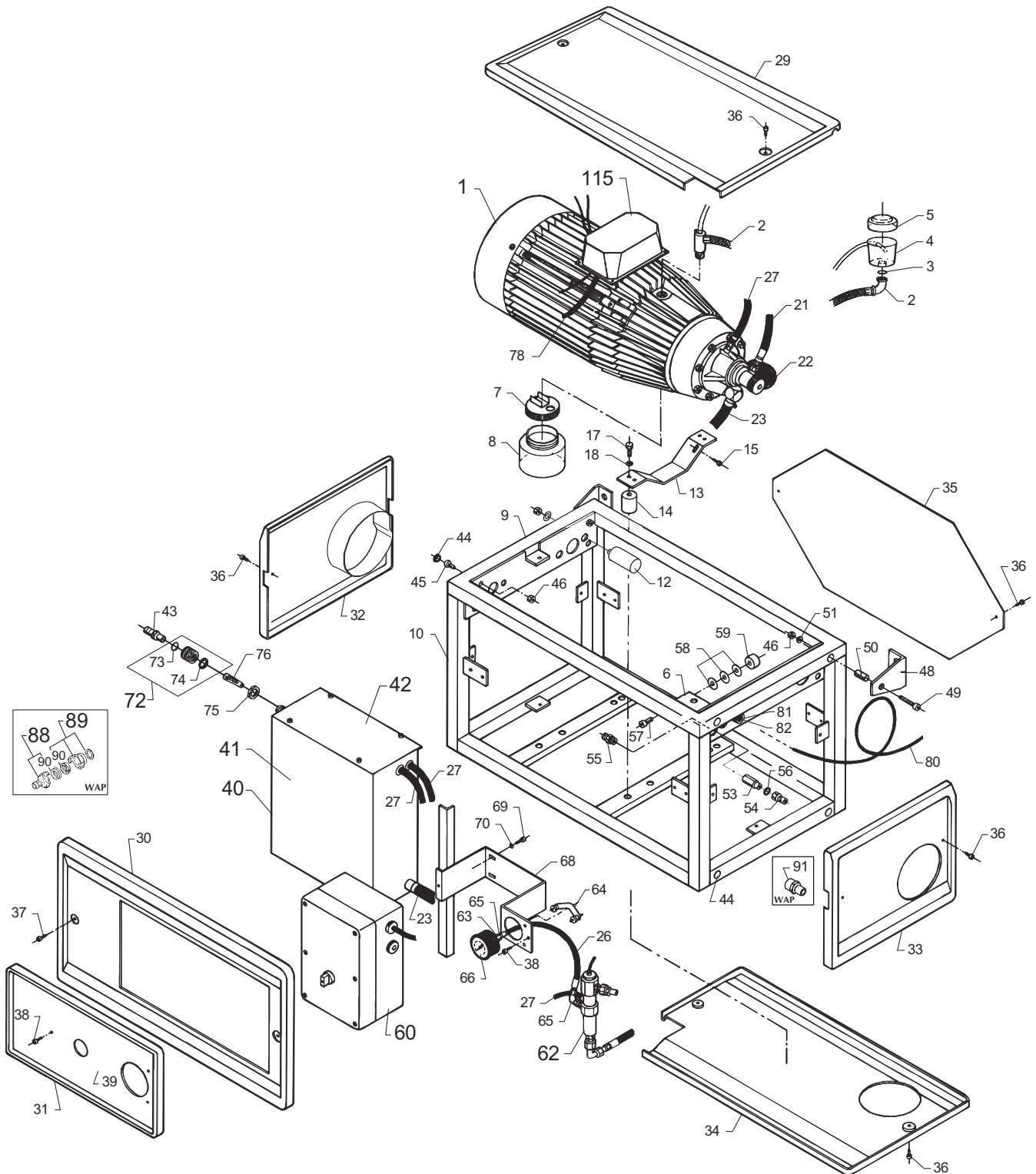

Pos. Ref.	Nr. No.	Betegnelsen Bezeichnung	Designation Désignation	KSA-1	KSA-2
39	-	Transfer Transfer Aufkleber Autocollant	KEW TECHNOLOGY		
-	6304407	40C3KSA-1		1	
-	6304409	44C3KRSA-1		1	
-	6304411	44C3KSA-1		1	
-	6304413	4403KSA-1		1	
-	6304414	52C3KSA-1		1	
39	-	Transfer Transfer Aufkleber Autocollant	WAP KEW TECHNOLOGIES		
-	6304446	40C3KSA-1		1	
-	6304448	44C3KRSA-1		1	
-	6304450	44C3KSA-1		1	
-	6304453	52C3KSA-1		1	
40	-	Svømmerhus, kompl. Water tank, compl. Schwimmergehäuse Bac à eau, compl.	Se side 30 See page 30 SieheSeite 30 Voir page 30	1	
41	6301116	Svømmerventil kompl. Float valve compl. Schwimmerventil kompl. Soupape flotteur compl.	Se side 30 See page 30 SieheSeite 30 Voir page 30	1	
42	6301115	Låg f. svømmehus Cover f. water tank Deckel f. Schwimmergeh. Courvercle p. bac à eau	Se side 30 See page 30 SieheSeite 30 Voir page 30	1	
43	1600659	Lynkoblingsnippel, lavtryk Quick coupling nipple, low pressure 3/4" Schnellkupplungsnippel, Niederdruck Adaptateur de la lance, basse pression		1	
43	1602473	Nippel Nipple 5/8" CH Nippel Adaptateur		1	
44	4600508	Blændprop Plug Propfen Ecrou		6	
45	1803352	Skrue Screw Schraube Vis		2	
-	1814586	Skrue, RF Screw, SS Schraube, RF Vis, INOX		2	
46	1802966	Møtrik, RF Nut, SS M10 Mutter, RF Ecrou, INOX		4	
48	6300105	Vægophæng Wall suspension Wandhängevorrichtung Support murale		2	
-	6300127	Vægophæng, RF Wall suspension, SS Wandhängevorrichtung, RF Support murale, INOX		2	
49	1803071	Skrue Screw M10x50 Schraube Vis		2	
-	1814003	Skrue, RF Screw, SS M10x50 Schraube, RF Vis, INOX		2	
50	6300301	Bøsning Bush Buchse Baque		2	
51	1813237	Skive Washer Scheibe Rondelle		2	

Pos. Ref.	Nr. No.	Betegnelsen Bezeichnung	Designation Désignation	KSA-1	KSA-2
53	6304325	Forskruning Threaded connection Verschraubung Raccord fileté		1	
54	1600493	Lynkoblingsnippel, højtryk Quick coupling nipple, high pressure 3/8" Schnellkupplungsnippel, Hochdruck Adaptateur de la lance, haute pression		1	
-	1603101	Lynkoblingsnippel RF, højtryk Quick coupling nipple SS, high pressure 3/8" Schnellkupplungsnippel RF, Hochdruck Adaptateur de la lance INOX, haute pression		1	
55	1602770	Forskruning Threaded connection Verschraubung Raccord fileté		1	
56	1801075	Skive Washer Scheibe Rondelle		1	
57	1803089	Skrue Screw M8x12 Schraube Vis		1	
58	1800796	Skive Washer Scheibe Rondelle		3	
59	1803097	Svingningsdæmper Vibration damper Schwingungsdämpfer Amortisseur de vibration		1	
60	-	El-kasse, monteret El. control unit, mounted El. Steuerungseinheit Boîtier électr., monté	Se side 34 See page 34 SieheSeite 34 Voir page 34	x	
62	-	Strømningskontakt Flow switch, compl. Strömungsschalter Circulation sélecteur	Se side 28 See page 28 SieheSeite 28 Voir page 28	1	
63	1600535	Manometertilslutning Pressure gauge connection Manometeranschluß Raccord pour manomètre		1	
64	1808088	Spændestykke f. manometer Clamp Spannstück Pièce de serrage		1	
65	6300207	Vinkel mont. Elbow mounted Winkel mont. Coude mont.		2	
66	3600301	Manometer Pressure gauge Manometer Manomètre		1	
68	6304310	Beslag Bracket Beschlag Garniture		1	
69	1803824	Skrue Screw Schraube Vis		4	
70	1800887	Skive Washer Scheibe Rondelle		4	
72	1602945	Lynkobling kompl. Quick coupling compl. Schnellkupplung kompl. Raccord rapide compl.		1	

Maskine, monteret / Machine, monté / Maschine, montiert / Appareil, monté

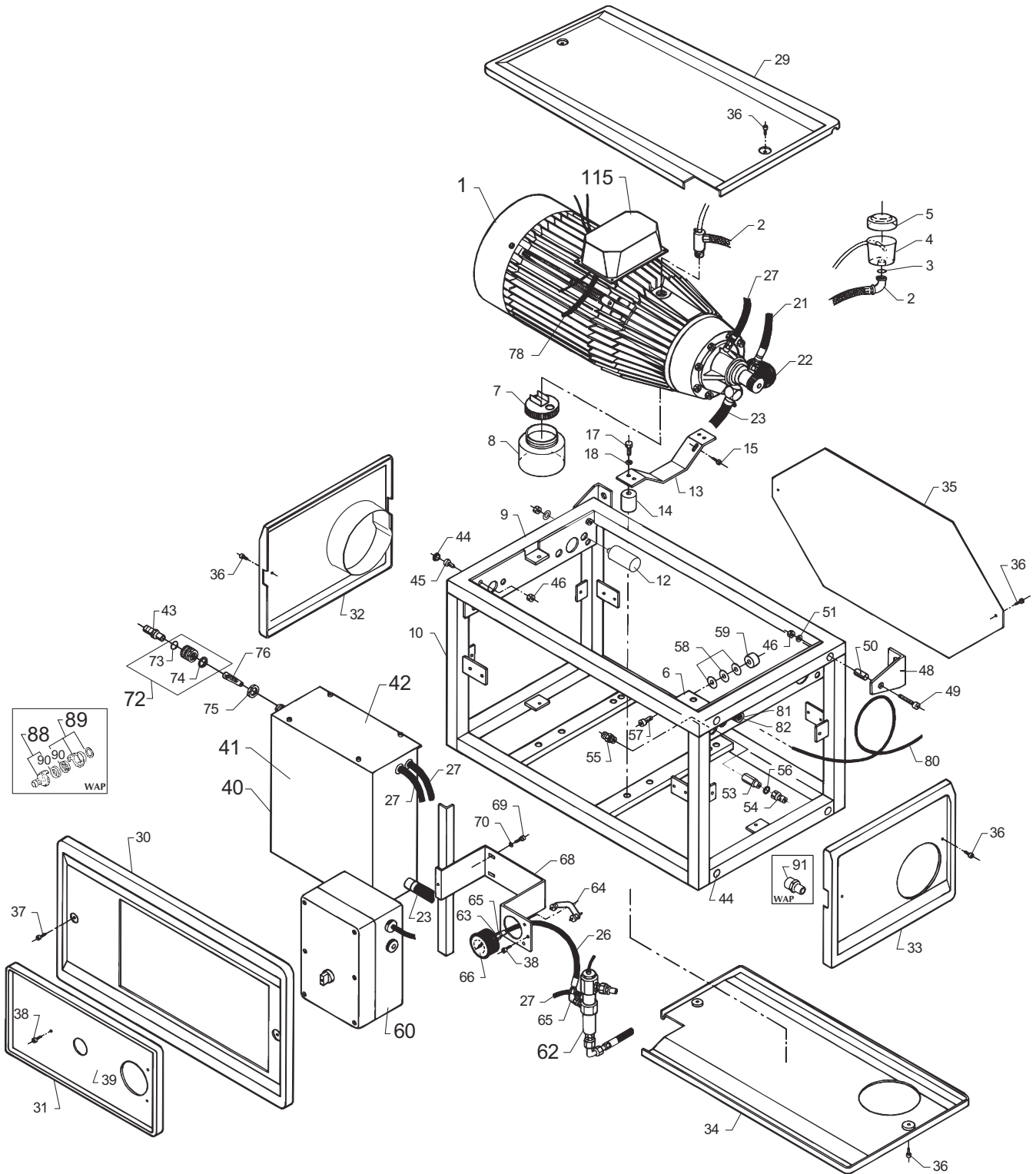

Pos. Ref.	Nr. No.	Betegnelse Bezeichnung	Designation Désignation	KSA-1	KSA-2
73	3000320	O-ring O-ring O-Ring Joint torique		1	
74	3001237	Pakning Gasket Dichtung Joint		1	
75	1800341	Kontramøtrik Lock nut Gegenmutter Ecrou contre		1	
76	6100941	Filter Filter Filter Filtre		1	
78	6303258	Kabel (intern) Cable Kabel Câble		1	
80	6303259	Tilgangskabel El. cable Anschlußkabel Câble électrique		1	
-	6303260	Tilgangskabel El. cable USA, N, CN, offshore Anschlußkabel Câble électrique		1	
81	3800760	Trækaflastning Bracket Zugentlastung Pass fil		1	
82	3800786	Kontramøtrik Lock nut Gegenmutter Ecrou contre		1	
88	1311	Geka koblingsnippel 3/4" Geka-coupling nipple 3/4" Geka-Schlauchtülle 3/4" Coupleur mâle Geka 3/4"	WAP	1	
89	1718	Geka koplning 3/4" Geka-threaded piece 3/4" Geka-Gewindestück 3/4" Coupleur Geka 3/4"	WAP	1	
90	6502	Pakning for Geka kobling Packing for Geka coupling Dichtung für Geka-Kupplung Joint pour coupleur Geka	WAP	2	
91	1609335	Konverter (højtryk) Converter (high pressure) Konverter (Hochdruck) Convertisseur (haute pression)	WAP	1	
115	-	El-monteringsplade, komp. El. mounting plate, compl. Leitungsplatte, kompl. Plaque électrique, compl.	Se side 32 See page 32 Siehe Seite 32 Voir page 32	x	
-	-	Instruktionsbog Instruction manual Betriebsanweisung Manuel d'instruction	WAP KEW TECHNOLOGIES	x	
-	6307950		DK, N, S, (SF)	x	
-	6307954		GB, D, F, NL	x	

Pos. Ref.	Nr. No.	Betegnelse Bezeichnung	Designation Désignation	KSA-1	KSA-2

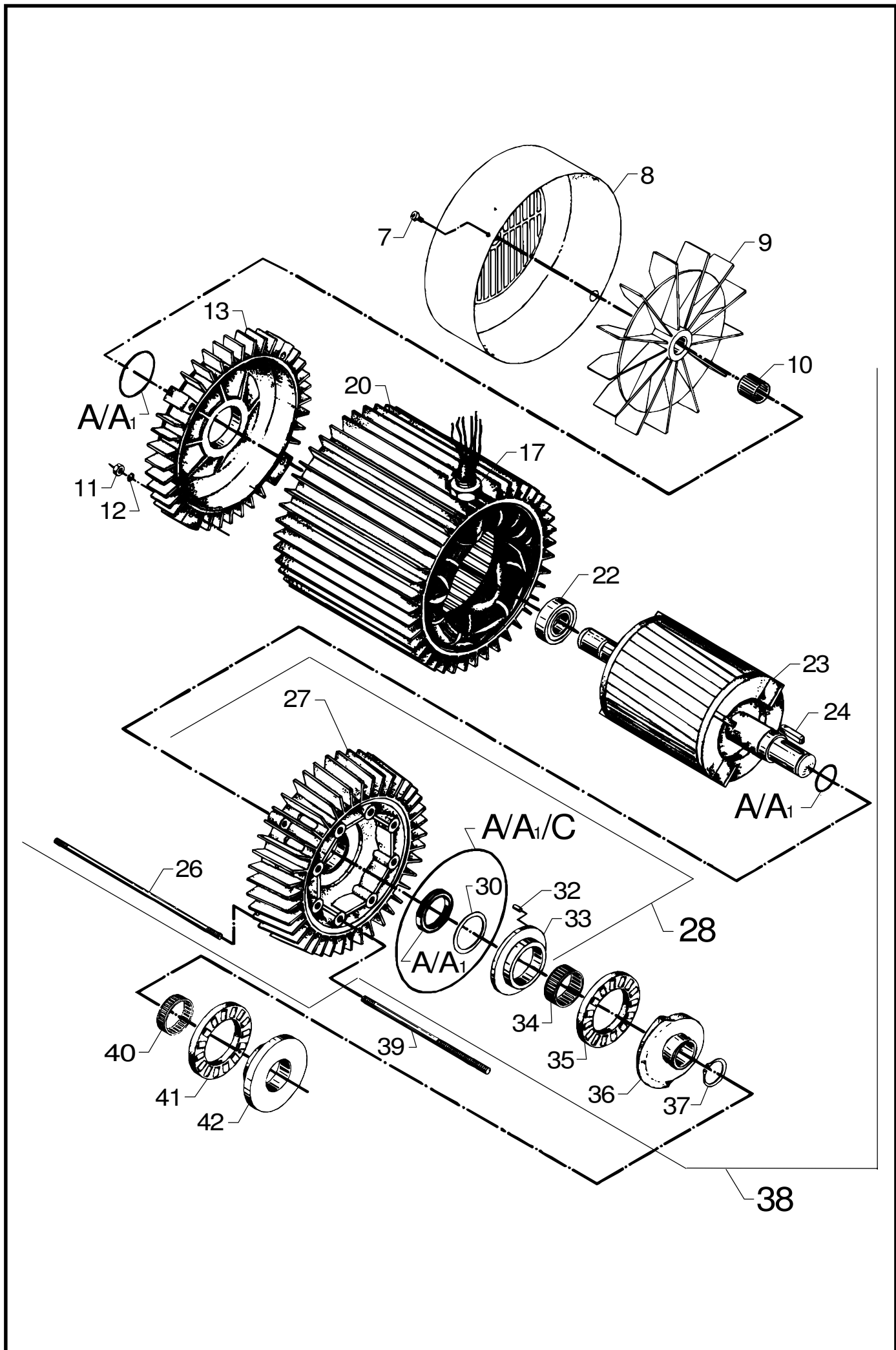

Pos. Ref.	Nr. No.	Betegnels Bezeichnung	Designation Désignation	KSA-1	KSA-2
1	-	Motorpumpeenhed, komplet Motor/pump unit, complete Motorpumpenkörper, komplett Corps de moteur/pompe, compl.	KSA-1	x	
7	1803956	Skrue M4x12 Screw Schraube Vis		2	
8	6100609	Ventilatorskærm Fan guard Ventilatorschutzblech Capot ventilateur		1	
9	6100607	Ventilator Fan Ventilator Ventilateur		1	
10	1802503	Låsering Circlip Schließring Anneau		1	
11	1803725	Møtrik Nut Mutter Ecrou		4	
12	1801182	Fjederskive Spring washer Federscheibe Rondelle ressort		4	
13	6100611	N-lejedæksel Rear bearing cover N-Lagerdeckel AR-flasque de carter		1	
17	6220727	Bøsning Bush Buchse Baque		1	
20	-	Stator med statorhus 5,5 kW Stator with stator housing Stator mit Statorgehäuse Stator avec enveloppe de stator			
-	6100850	5,0kW/1x208-230V, 60Hz		x	
-	6100824	3 x 415-440 V, 50 Hz		x	
-	6100825	3 x 220/380V, 50 Hz & 3 x 210-250/380-480 V, 60 Hz		x	
22	3200623	N-leje Rear bearing N-Lager AR-roulement		1	
23	6100998	Aksel med 145 mm rotor Shaft with 145 mm rotor Welle mit 145 mm Rotor Arbre avec 145 mm rotor		1	
24	3200672	Feder Key Federkeil Clavette		1	
26	6100711	Stagbolt Stud Stehbolzen Entretoise		4	
26	6100712	Stagbolt L=306mm Stud Stehbolzen Entretoise		4	
27	6101749	D-lejedæksel Front bearing cover D-Lagerdeckel AV-flasque de carter		1	
28	6101750	D-lejedæksel, komplet Front bearing cover, complete D-Lagerdeckel, komplett AV-flasque de carter, compl.		x	
30	6100995	Skive Washer Scheibe Rondelle		1	
32	6100996	Styrestift Guide pin Kegelstift Goupille		1	

Pos. Ref.	Nr. No.	Betegnels Bezeichnung	Designation Désignation	KSA-1	KSA-2
33	107120703	Lejeskive Bearing track Lagerscheibe Rondelle de palier		1	
34	3200656	Nåleleje Needle bearing Nadellager Roulement à aiguille		1	
35	3200615	Rulleleje Roller bearing Rollenlager Roulement		1	
36	107120715	Skråskive Wobble disc 11, 50 Hz Taumelscheibe Disque oblique		x	
-	107120708	Skråskive Wobble disc 4, 60 Hz Taumelscheibe Disque oblique		x	
37	1802511	Seegerring Seeger circlip Seeger-Ring Anneau Seeger		1	
38	-	Motor, komplet Motor, complete Motor, komplett Moteur, compl.			
-	6101718	5.5 kW, 50Hz, 3x380/415V		*8	x
-	6101719	5.5 kW, 50Hz, 3x220/380V		*8	x
-	6101720	5.5 kW, 60Hz, 3x220/460V		*5	x
39	6100710	Stagbolt Stud Stehbolzen Entretoise		8	
-	6301368	Stagbolt Stud C3 Stehbolzen Entretoise		8	
40	3200664	Nåleleje Needle bearing Nadellager Roulement à aiguille		1	
41	3200615	Aksialrulleleje Axial roller bearing Axialrollenlager Roulement		1	
42	107120704	Lejeskive Bearing track Lagerscheibe Plaque de palier		1	

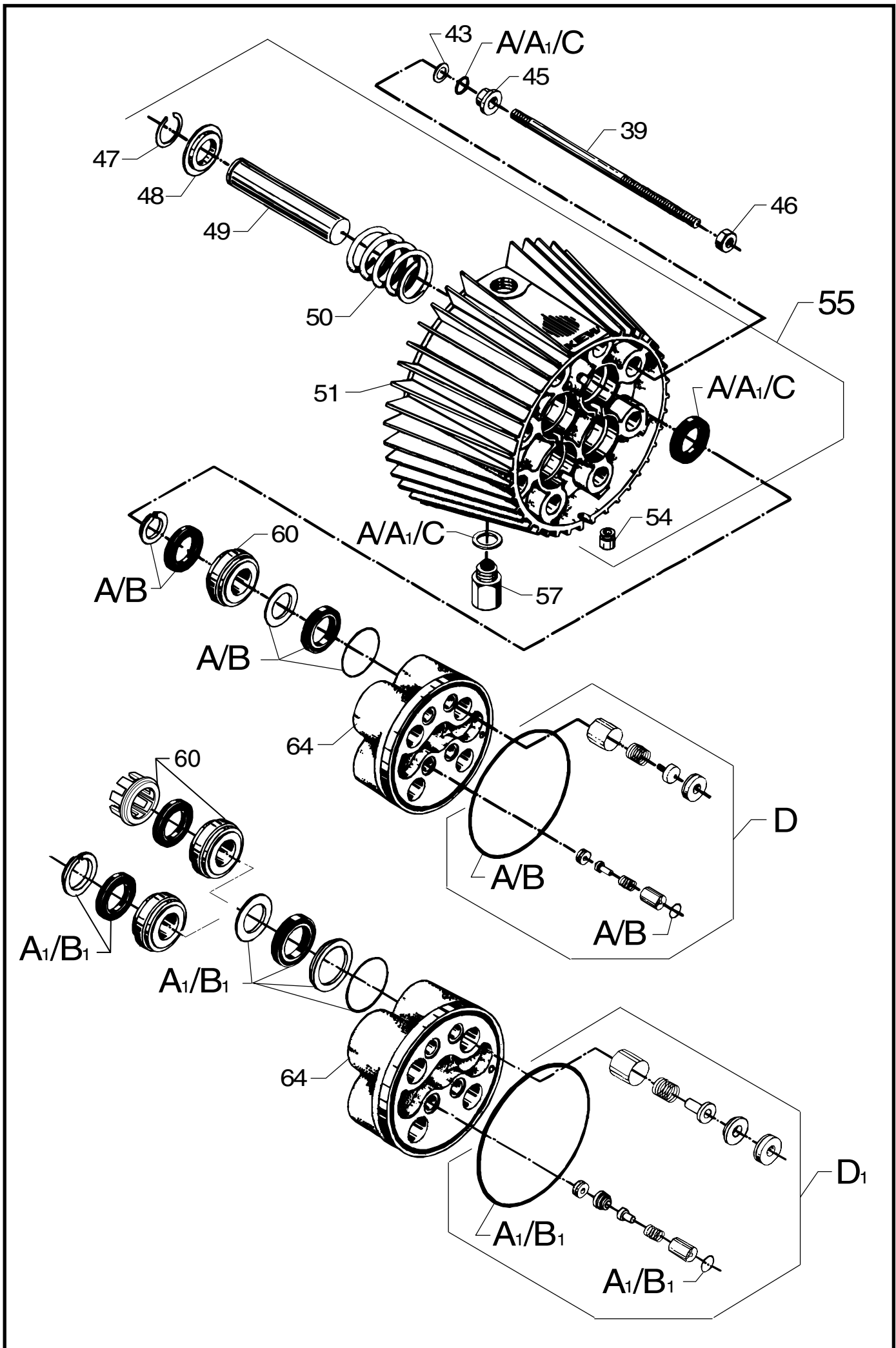

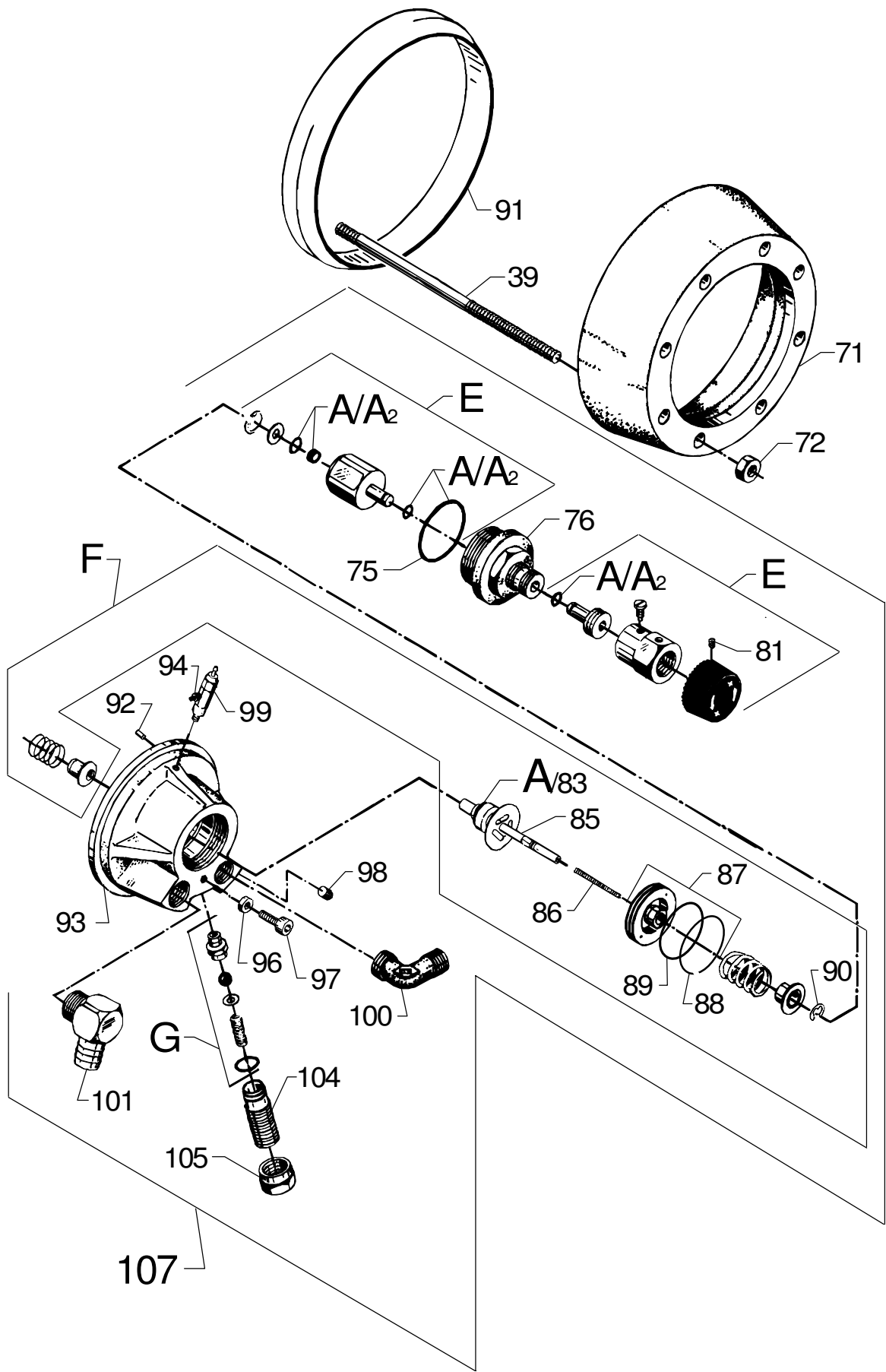

Pos. Ref.	Nr. No.	Betegnelse Bezeichnung	Designation Désignation	KSA-1	KSA-2
A ₂	1119568	Rep.sæt, pakninger f. omløbsventil Rep.kit, gaskets f. by-pass valve C3 Rep.satz, Dichtungen f. Umlaufventil Kit de joints p. soupape by-pass		x	
E	1118538	Rep.sæt, greb f. omløbsventil, Rep.kit, adj. mechanism f. by-pass valve Rep.satz, Justiereinrichtung f. Umlaufven. Kit de bouton de soupape by-pass		x	
F	1119315	Rep.sæt, omløbsventil Rep.kit, by-pass valve Rep.satz, Umlaufventil Kit de soupape by-pass		x	
G	1118512	Rep.sæt, sikkerhedsventil Rep.kit, safety valve Rep.satz, Überdruckventil Kit de soupape de sûreté		x	
71	6100602	Spændering Retaining ring Spanning Flaque AV pompe		1	
72	1800465	Møtrik M10 Nut Mutter Ecrou		8	
75	3001179	O-ring O-ring O-Ring Joint torique		1	
76	6100984	Bøsning Bushing Buchse Manchon		1	
81	1802602	Kraterskrue Crater-point screw Kraterskrue Vis		1	
83	3000460	O-ring O-ring O-Ring Joint torique		1	
85	6400143	Ventilkegle, komplet Valve cone, complete Ventilkegel, komplett Cône p. clapet, compl.		x	
86	2600286	Fjeder Spring Feder Ressort		1	
87	6228554	Stempel, kompl. Piston, compl. Kolben, komplett Piston, compl.		1	
88	6101061	Stempelring Piston ring Kolbenring Anneau piston		1	
89	3001716	O-ring O-ring O-Ring Joint torique		1	1
90	6101069	Seegerring Segger circlip ring Seeger-Ring Anneau Seeger		1	
91	6301392	Ring Ring ø 160, C3 Ring Anneau		1	
92	6100996	Styrestift Pilot pin Kegelstift Goupille		1	
93	6101042	Ventildæksel Valve cover Ventildeckel Corp by-pass		1	
94	1602606	Ligeforskruning Threaded connection Verschraubung Raccord fileté		1	

Pos. Ref.	Nr. No.	Betegnelse Bezeichnung	Designation Désignation	KSA-1	KSA-2
96	6100985	Låseskive Lock washer Haltescheibe Disque de blocage		1	
97	1802636	Skrue Screw Schraube Vis		1	
98	1602333	Rørprop Pipe plug Rohrschlußstück Bouchon de tuyau		1	
99	6221552	Udluftningsventil, kompl. Venting valve, compl. Entlüftungsventil, kompl. Vis de purgeur, compl.		1	
100	1600444	Vinkel Elbow Winkel Coude		1	
101	6101752	Slangestuds, vinkel Hose socket, elbow Schlauchstutzen, Winkel Raccord de flexible, coude		1	
104	6100940	Justerskrue Adjustment screw Justierskrue Vis de réglage		1	
105	6100928	Kontramøtrik Lock nut Gegenmutter Ecrou contre		1	
107	6301118	Omløbsventil, komplet By-pass valve, complete Umlaufventil, komplett Soupape by-pass, compl.		x	
-	5218433	Pump Oil 150, 1 x 1 l.			

Maskine, monteret / Machine, monté / Maschine, montiert / Appareil, monté

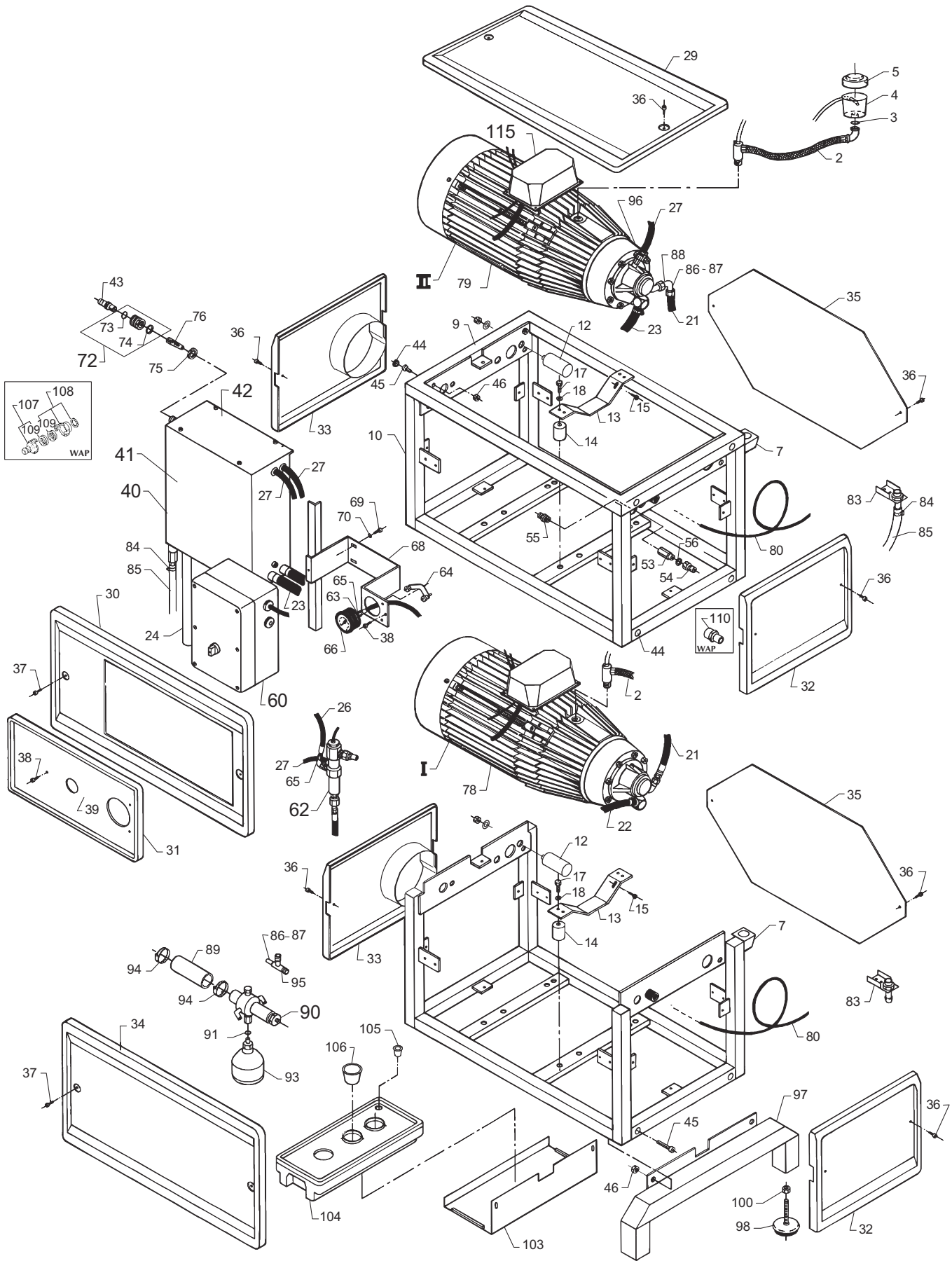

Pos. Ref.	Nr. No.	Betegnelse Bezeichnung	Designation Désignation	KSA-1	KSA-2
-	-	Maskine, monteret Machine, mounted Maschine, montiert Appareil, monté	KSA-2	x	
I,II	-	Motorpumpeenhed Motor/pump unit Motorpumpenkörper Unité moto-pompe	Se side 22 See page 22 Siehe Seite 22 Voir page 22	x	
2	6300061	Olieslange Oil hose Ölschlauch Durite à fuel		2	
3	3000320	O-ring O-ring O-Ring Joint torique		1	
4	6300392	Olieglass Oil reservoir Ölglas Réservoir à huile usée		2	
5	2201854	Låg f. olieglass Cover f. oil reservoir Ölglasdeckel Couvercle		2	
7	6300060	Beslag f. olieglass Retainer for oil reservoir Halter für ölglas Support réservoir à huile		2	
-	6300064	Beslag f. olieglass, RF Retainer for oil reservoir, SS Ölglashalter, RF Support réservoir à huile, INOX		1	
9	6300102	Overramme Top frame Oberrahmen Chassis supérieure		1	
-	6300126	Overramme, RF Top frame, SS Oberrahmen, RF Châssis supérieure, INOX		1	
10	6300101	Modulramme Module frame Modulrahmen Chassis de module		2	
-	6300125	Modulramme, RF Module frame, SS Modulrahmen, RF Châssis de module, INOX		1	
13	6304330	Pumpekonsol Pump bracket Pumpenkonsole Console de Pompe		4	
14	1803048	Svingningsdæmper Vibration damper Schwingungsdämpfer Amortisseur de vibration		8	
15	1802651	Taptite skrue Taptite screw M10x20 Taptite-Schraube Vis Taptite		8	
17	1800788	Skrue Screw M8x12 Schraube Vis		16	
-	1810266	Skrue, RF Screw, SS M8x12 Schraube, RF Vis, INOX		16	
18	1801398	Skive Washer Scheibe Rondelle		16	
-	1810274	Skive, RF Washer, SS Scheibe, RF Rondelle, INOX		16	
21	6300108	Afgangsslange Outlet hose Auslaßschlauch Tuyau de décharge		3	

Pos. Ref.	Nr. No.	Betegnelse Bezeichnung	Designation Désignation	KSA-1	KSA-2
22	5206230	Slange Hose Schlauch Flexible	(L=600)		1
23	5206230	Slange Hose Schlauch Flexible	(L=440)		1
24	6300461	Overløbslange Overflow hose Überlaufschlauch Flexible	L=430		1
26	6300206	Manometerslange Hose f. pressure gauge Schlauch f. Manometer Flexible pour manomètre			1
27	5206298	Slange Hose Schlauch Flexible	(L=1000)		2
29	6304403	Topplade Top plate Abdeckplatte, oben Plaque en dessus			1
30	6304400	Frontplade Front cover Abdeckplatte, vorne Plaque avant			1
31	6304321	Instrumentplade Control panel Armaturenbrett Tableau de bord			1
32	6304398	Endeplade Rear cover Seitenplatte Plaque de côté			2
33	6304397	Endeplade Rear cover Seitenplatte Plaque de côté			2
34	6304399	Frontplade Front cover Abdeckplatte, vorne Plaque avant			1
35	6300340	Bagplade Rear cover Abdeckplatte, hinten Plaque arrière			2
36	1803030	Skrue Screw M5x12 Schraube Vis			14
-	1804475	Skrue, RF Screw, SS M5x12 Schraube, RF Vis, INOX			14
37	1803055	Fingerskrue Thumb screw Knebelschraube Vis de blocage			4
38	1801406	Skrue Screw Schraube Vis			3
-	1804848	Skrue, RF Screw, SS Schraube, RF Vis, INOX			3

Maskine, monteret / Machine, mount / Maschine, montiert / Appareil, monté

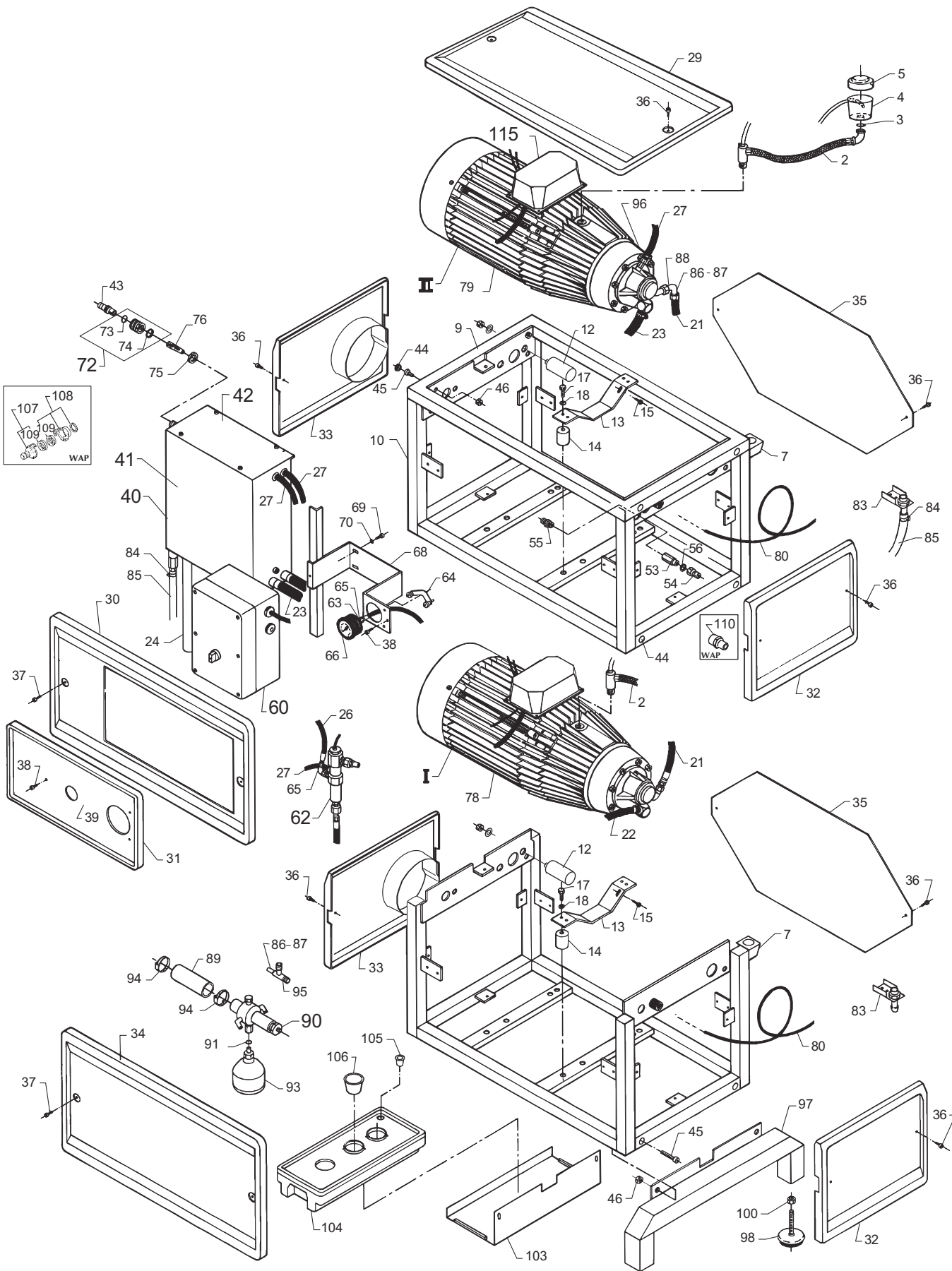

Pos. Ref.	Nr. No.	Betegnels Bezeichnung	Designation Désignation	KSA-1	KSA-2
39	-	Transfer Transfer Aufkleber Autocollant	KEW TECHNOLOGY		1
-	6304406	40C3KSA-2		1	
-	6304408	44C3KRSA-2		1	
-	6304410	44C3KSA-2		1	
-	6304412	4403KSA-2		1	
-	6304415	52C3KSA-2			1
39	-	Transfer Transfer Aufkleber Autocollant	WAP KEW TECHNOLOGIES		
-	6304445	40C3KSA-2		1	
-	6304447	44C3KRSA-2		1	
-	6304449	44C3KSA-2		1	
-	6304454	52C3KSA-2		1	
40	-	Svømmerhus, kompl. Water tank, compl. Schwimmergehäuse Bac à eau, compl.	Se side 30 See page 30 SieheSeite 30 Voir page 30		1
41	6301123	Svømmerventil kompl. Float valve compl. Schwimmerventil kompl. Soupape flotteur compl.	Se side 30 See page 30 SieheSeite 30 Voir page 30		1
42	6301115	Låg f. svømmehus Cover f. water tank Deckel f. Schwimmergeh. Courvercle p. bac à eau	Se side 30 See page 30 SieheSeite 30 Voir page 30		1
43	1600659	Lynkoblingsnippel, lavtryk Quick coupling nipple, low pressure 3/4" Schnellkupplungsnippel, Niederdruck Adapteur de la lance, basse pression			1
-	1602473	Nippel Nipple 5/8" CH Nippel Adapteur			1
44	4600508	Blændprop Plug Propfen Bouchon			12
45	1803352	Skrue Screw Schraube Vis			12
-	1814586	Skrue, RF Screw, SS Schraube, RF Vis, INOX			12
46	1802966	Møtrik Nut M10 Mutter Ecrou			12
53	6304325	Forskruning Threaded connection Verschraubung Raccord			1
54	1600493	Lynkoblingsnippel, højtryk Quick coupling nipple, high pressure 3/8" Schnellkupplungsnippel, Hochdruck Adapteur de la lance, haute pression			1
-	1603101	Lynkoblingsnippel RF, højtryk Quick coupling nipple SS, high pressure 3/8" Schnellkupplungsnippel RF, Hochdruck Adapteur de la lance INOX, haute pression			1
55	1602770	Ligeforskruning Threaded connection Verschraubung Raccord			1
56	1801075	Tætningsskive Sealing washer Dichtungsscheibe Rondelle d'étanchéité			1
60	-	El-kasse, monteret El. control unit, mount El. Steuerungseinheit Boîtier élect., monté	Se side 34 See page 34 SieheSeite 34 Voir page 34		x

Pos. Ref.	Nr. No.	Betegnels Bezeichnung	Designation Désignation	KSA-1	KSA-2
62	-	Strømningskontakt Flow switch, compl. Strömungsschalter Circulation sélecteur	Se side 28 See page 28 SieheSeite 28 Voir page 28		1
63	1600535	Manometertilslutning Pressure gauge connection Manometeranschluß Raccord pour manomètre			1
64	1808088	Spændestykke f. manometer Clamp Spannstück Pièce de serrage			1
65	6300207	Vinkel mont. Elbow mounted Winkel mont. Coude mont.			1
66	3600301	Manometer Pressure gauge Manometer Manomètre			1
68	6304310	Beslag Bracket Beschlag Garniture			1
69	1804475	Maskinskruer Screw M5x12 Schraube Vis			4
70	1800887	Skive Washer Scheibe Rondelle			4
72	1602945	Lynkobling komp. Quick coupling compl. Schnellkupplung komp. Raccord rapide comp.			1
73	3000320	O-ring O-ring O-Ring Joint torique			1
74	3001237	Pakning Gasket Dichtung Joint			1
75	1800341	Kontramøtrik Lock nut Gegenmutter Ecrou contre			1
76	6100941	Filter Filter Filter Filtre			1
78	6303261	Kabel (intern) Cable Kabel Câble			1
79	6303258	Kabel (intern) Cable Kabel Câble			1
80	6303259	Tilgangskabel El. cable Anschlusskabel Câble électrique			1
-	6303260	Tilgangskabel El. cable USA, N, CN, offshore Anschlusskabel Câble électrique			1
81	3800760	Trækafastning Bracket Zugentlastung Passe fil			2

Maskine, monteret / Machine, monté / Maschine, montiert / Appareil, monté

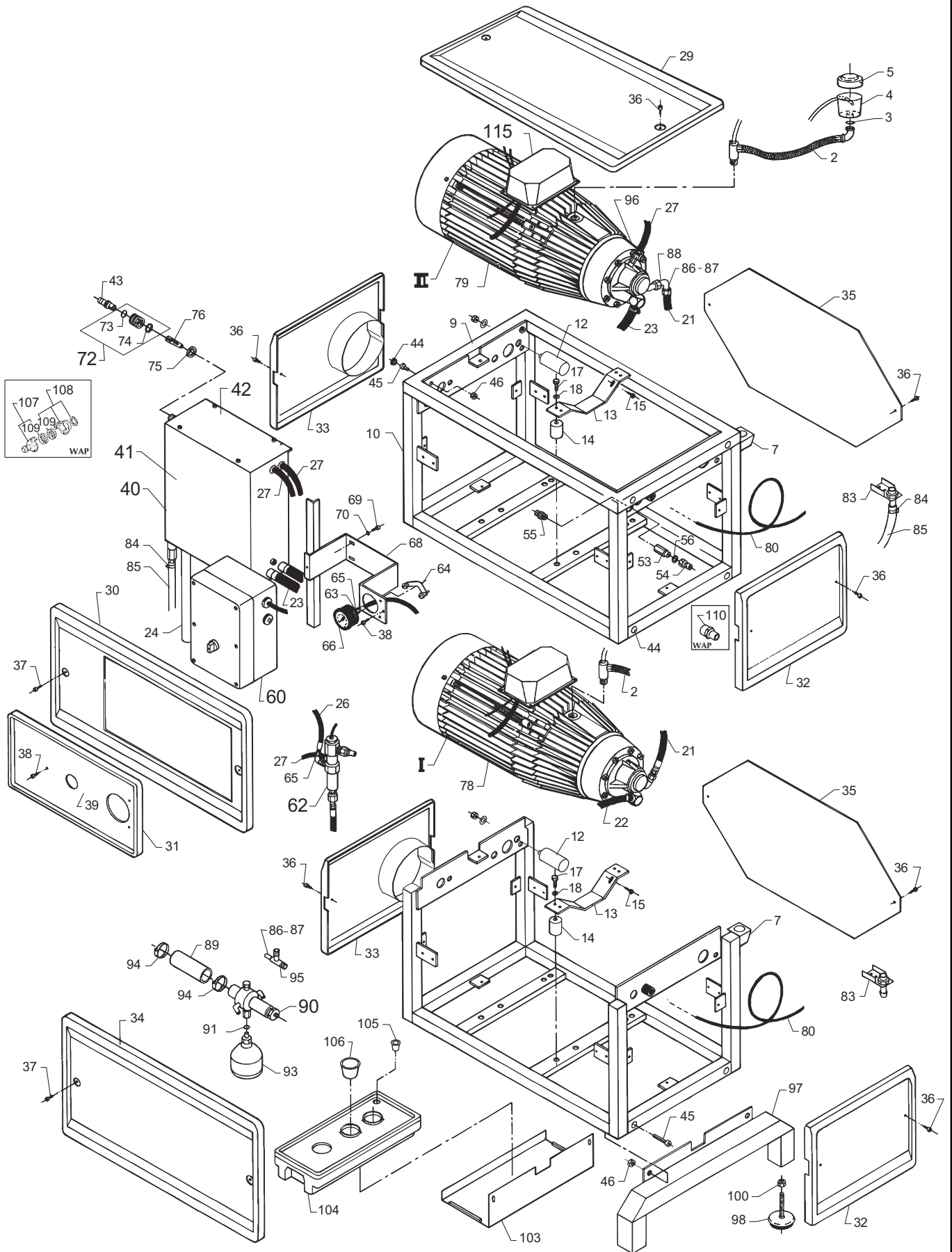

Pos. Ref.	Nr. No.	Betegnelse Bezeichnung	Designation Désignation	KSA-1	KSA-2
82	3800786	Kontramøtrik Lock nut Gegenmutter Ecrou contre			2
83	6300062	Studs med beslag Socket with fitting Stutzen mit Beschlag Raccord avec garniture			2
84	1805100	Spændebånd Hose clip Schlauchschelle Collier de serrage			5
85	5206330	Slamslange Sludge hose Schlammanschlauch Flexible	(L=475)		1
86	1600451	Omløber Union nut Überwurfmutter Ecrou			6
87	1600469	Skæring Cutting ring Schneidring Anneau coudante			6
88	1601012	Vinkelforskrøning Elbow Winkel Coude			1
89	6400460	Afgangsslange Outlet hose Auslaßschlauch Tuyau de décharge	L=150		1
90	6301119	Overstrømsventil, kompl. Overflow valve, compl. Überlaufventil, kompl. Soupape de passage	Se side 28 See page 28 SieheSeite 28 Voir page 28		1
91	3000262	O-ring O-ring O-Ring Joint torique			1
93	4600575	Trykudligner Pressure accumulator Druckausgleicher Accumulateur de pression			1
95	1602085	T-stykke T-piece T-Stück Piece à T			1
94	1801869	Spændebånd Hose clip Schlauchschelle Collier de serrage			3
96	1801034	Spændebånd Hose clip Schlauchschelle Collier de serrage			2
97	6301830	Gulvkonsol Floor bracket Bodenkonsole Console			2
-	6301829	Gulvkonsol, RF Floor bracket, SS Bodenkonsole, RF Console, INOX			2
98	4602421	Maskinsko Supporting block Stützklötz Support de la machine			4
100	1801620	Møtrik Nut M12 Mutter Ecrou			4
103	6300188	Holder for slambakke Attachment for sludge tray Halter für Schlammbehälter Support réservoir d'huile usée			1
-	6301164	Holder for slambakke, RF Attachment for sludge tray, SS Halter für Schlammbehälter, RF Support réservoir d'huile usée, INOX			1

Pos. Ref.	Nr. No.	Betegnelse Bezeichnung	Designation Désignation	KSA-1	KSA-2
104	6301114	Slambakke Sludge tray Schlammbehälter Réservoir d'huile usée			1
105	4601035	Blændprop, sort Hole plug, black Verschlusspfropfen, schwarz Bouchon plastique, noir			1
106	4601143	Blændprop Hole plug Verschlusspfropfen Bouchon plastique			2
107	1311	Geka koblingsnippel 3/4" Geka-coupling nipple 3/4" Geka-Schlauchtülle 3/4" Coupleur mâle Geka 3/4"	WAP		1
108	1718	Geka kopling 3/4" Geka-threaded piece 3/4" Geka-Gewindestück 3/4" Coupleur Geka 3/4"	WAP		1
109	6502	Pakning for Geka kobling Packing for Geka coupling Dichtung für Geka-Kupplung Joint pour coupleur Geka	WAP		2
110	1609335	Konverter (højtryk) Converter (high pressure) Konverter (Hochdruck) Convertisseur (haute pression)	WAP		1
115	-	El-monteringsplade, kompl. El.mounting plate, compl. Leitungsplatte, kompl. Plaque électrique, compl.	Se side 32 See page 32 SieheSeite 32 Voir page 32		x
-	-	Instruktionsbog Instruction manual Betriebsanweisung Manuel d'instruction	WAP KEWTECHNOLOGIES		x
-	6307950		DK, N, S, (SF)		x
-	6307954		GB, D, F, NL		x

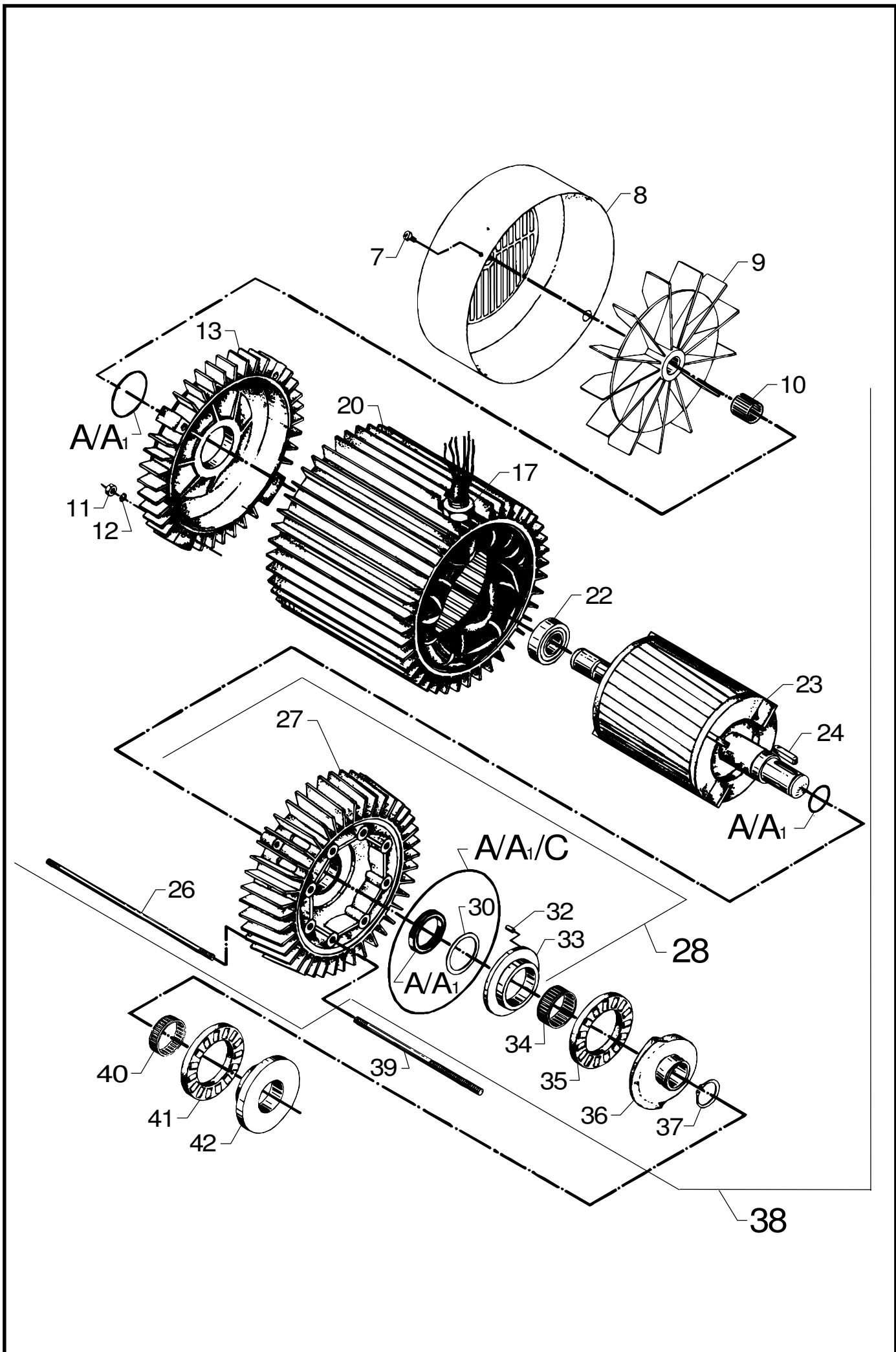

Pos. Ref.	Nr. No.	Betegnels Bezeichnung	Designation Désignation	KSA-1	KSA-2
I, II	-	Motorpumpeenhed Motor/pump unit Motorpumpenkörper Unité moto-pompe	KSA-2		x
7	1803956	Skrue M4x12 Screw Schraube Vis			2
8	6100609	Ventilatorskærm Fan guard Ventilatorschutzblech Ecran de ventilateur			1
9	6100607	Ventilator Fan Ventilator Ventilateur			1
10	1802503	Låsering Lock ring Schließring Anneau			1
11	1803725	Møtrik Nut Mutter Ecrou			4
12	1801182	Fjederskive Spring washer Federscheibe Rondelle ressort			4
13	6100611	N-lejedæksel Rear bearing cover N-Lagerdeckel AR-flasque de carter			1
17	6220727	Bøsning Bush Buchse Baque			1
20	-	Stator med statorhus 5,5 kW Stator with stator housing Stator mit Statorgehäuse Stator avec enveloppe de stator			
-	6100850	5,0kW/1x208-230V, 60Hz			x
-	6100824	3 x 415-440 V, 50 Hz			x
-	6100825	3 x 220/380V, 50 Hz 3 x 210-250/380-480 V, 60 Hz			x
22	3200623	N-leje Rear bearing N-Lager AR-roulement			1
23	6100998	Aksel med 145 mm rotor Shaft with 145 mm rotor Welle mit 145 mm Rotor Arbre avec 145 mm rotor			1
24	3200672	Feder Key Federkeil Clavette			1
26	6100711	Stagbolt Stud Stehbolzen Entretoise			4
27	6101749	D-lejedæksel Front bearing cover D-Lagerdeckel AV-flasque de carter			1
28	6101750	D-lejedæksel, komplet Front bearing cover, complete D-Lagerdeckel, komplett AV-flasque de carter, compl.			x
30	6100995	Skive Washer Scheibe Rondelle			1
32	6100996	Styrestift Pilot pin Kegelstift Goupille			1

Pos. Ref.	Nr. No.	Betegnels Bezeichnung	Designation Désignation	KSA-1	KSA-2
33	107120703	Lejeskive Bearing track Lagerscheibe Rondelle de palier			1
34	3200656	Nåleleje Needle bearing Nadellager Roulement à aiguille			1
35	3200615	Rulleleje Roller bearing Rollenlager Roulement			1
36	107120715	Skråskive Wobble disc 11, 50 Hz Taumelscheibe Disque oblique			x
-	107120708	Skråskive Wobble disc 4, 60 Hz Taumelscheibe Disque oblique			x
37	1802511	Seegerring Seeger circlip ring Seeger-Ring Anneau Seeger			1
38	-	Motor, komplet Motor, complete Motor, komplett Moteur, compl.			
-	6101718	5.5 kW,50Hz, 3x380/415V		*8	x
-	6101719	5.5 kW, 50Hz, 3x220/380V		*8	x
-	6101720	5.5 kW, 60Hz, 3x220/460V		*5	x
39	6100710	Stagbolt Stud Stehbolzen Entretoise			8
-	6301368	<i>Stagbolt</i> <i>Stud C3</i> <i>Stehbolzen</i> <i>Entretoise</i>			8
40	3200664	Nåleleje Needle bearing Nadellager Roulement à aiguille			1
41	3200615	Aksialrulleleje Axial roller bearing Axialrollenlager Roulement			1
42	107120704	Lejeskive Bearing track Lagerscheibe Plaque de palier			1

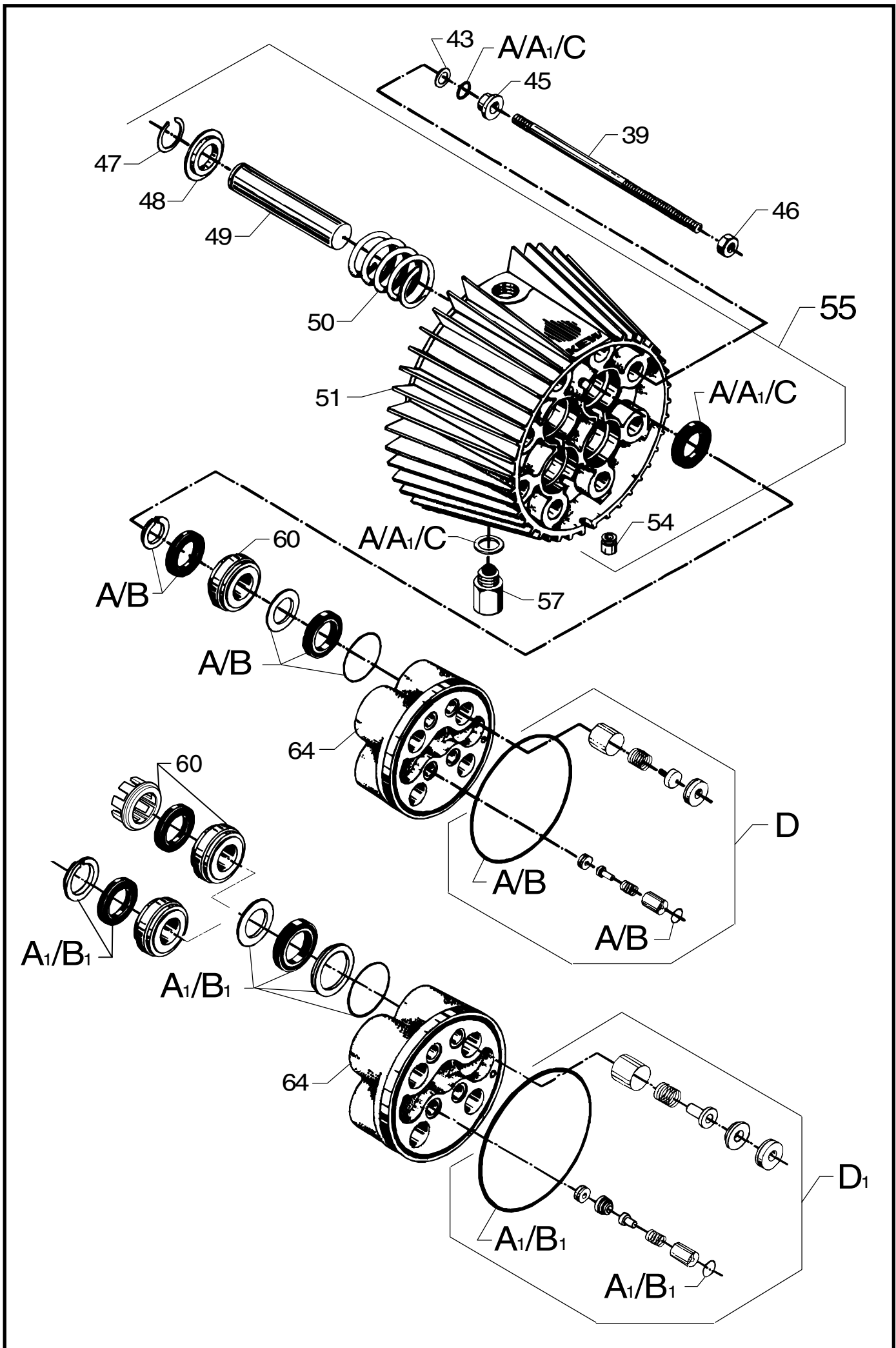

Pos. Ref.	Nr. No.	Betegnelse Bezeichnung	Designation Désignation	KSA-1	KSA-2
A	1119567	Rep.sæt, pakninger Rep.kit, gaskets Rep.satz, Dichtungen Kit de joints			x
A ₁	1119570	Rep.sæt, pakninger Rep.kit, gaskets C3 Rep.satz, Dichtungen Kit de joints			x
B	1119035	Rep.sæt, pakninger (reduceret) Rep.kit, gaskets (reduced) Rep.satz, Dichtungen (reduziert) Kit de joints (réduit)			x
B ₁	1119571	Rep.sæt, pakninger (reduceret) Rep.kit, gaskets (reduced) C3 Rep.satz, Dichtungen (reduziert) Kit de joints (réduit)			x
C	1119820	Rep.sæt, olietætning Rep.kit, oil seal Rep.satz, Öldichtung Kit de joint étanche à l'huile			x
D	1119310	Rep.sæt, ventilsystem Rep.kit, valve system Rep.satz, Ventilsystem Kit de système de soupape			x
D ₁	1119195	Rep.sæt, ventilsystem Rep.kit, valve system C3 Rep.satz, Ventilsystem Kit de système de soupape			x
43	6100718	Skive Washer Scheibe Rondelle			8
45	6100719	Trykring Thrust collar Druckring Anneau d'arrêt			8
46	1800465	Møtrik M10 Nut Mutter Ecrou			8
47	1802529	Låsering Circlip Schließring Anneau			4
48	6100666	Ring til returfjeder Ring for return spring Ring für Rückzugfeder Anneau pour ressort de rappel			4
49	6100901	Stempel Piston Druckkolben Piston			4
-	6301166	Keramik stempel Piston ceramic C3 Keramischer Druckkolben Piston ceramique			4
50	2602274	Returfjeder Return spring Rückzugfeder Ressort de rappel			4
50	102602517	Returfjeder Return spring C3 Rückzugfeder Ressort de rappel			4
51	6100610	Cylinderblok Cylinder block Zylinderblock Carter-cylindre			1
54	6100919	Dryptud Drip nozzle Tropfendüse Tuyau d'égouttage			1
55	6101702	Cylinderblok, komplet Cylinder block, complete Zylinderblock, komplett Carter-cylindre, compl.			x
-	6300071	Cylinderblok, komplet Cylinder block, complete C3 Zylinderblock, komplett Carter-cylindre, compl.			x

Pos. Ref.	Nr. No.	Betegnelse Bezeichnung	Designation Désignation	KSA-1	KSA-2
57	6150400	Bundprop Drain plug Verschlußpropfen Bouchon de vidange			1
60	6100631	Trykring Thrust collar Druckring Anneau d'arrêt			4
-	107120700	Trykring & Støttering Thrust collar & Back-up ring Druckring & Stützring Anneau d'arrêt & Anneau d'appui			4
64	6100907	Topstykke Cylinder head Zylinderkopf Culasse			1
-	6301335	Topstykke Cylinder head C3 Zylinderkopf Culasse			1

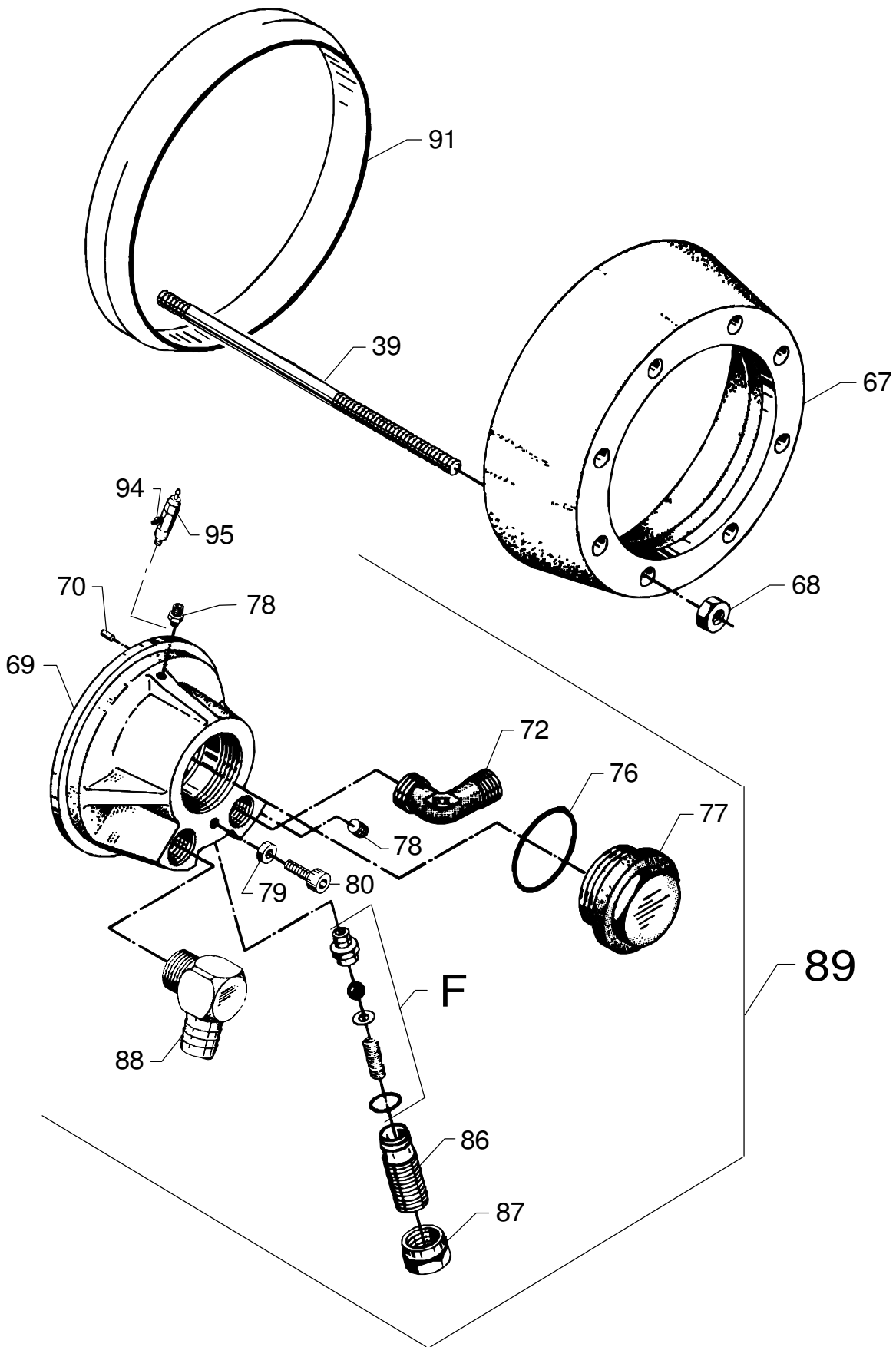

Pos. Ref.	Nr. No.	Betegnelse Bezeichnung	Designation Désignation	KSA-1	KSA-2
F	1118512	Rep.sæt, sikkerhedsventil Rep.kit, safety valve Rep.satz, Überdruckventil Kit de soupape de sûreté			x
67	6100602	Spændering Retaining ring Spannring Flaque AV pompe			1
68	1800465	Møtrik M10 Nut Mutter Ecrou			8
69	6301304	Ventildæksel Valve cover Ventildeckel Corp by-pass			1
70	6100996	Styrestift Pilot pin Kegelstift Goupille			1
72	1600444	Vinkel Elbow Winkel Coude			1
76	3001096	O-ring O-ring O-Ring Joint torique			1
77	6301303	Prop Plug Verschlußschraube Bouchon			1
78	1602333	Rørprop 1/8" Screw-plug Schraubverschluß Bouchon de tuyau	I 2 Stk. - II 1 stk. I 2 Pcs. - II 1 Piece I 2 Stück - II 1 Stück I 2 Pièces - II 1 Pièce		
79	6100985	Låseskive Lock washer Arretierscheibe Disque de blocage			1
80	1802636	Skrue M6x12 Screw Schraube Vis			1
86	6100940	Justerskrue Adjusting screw Justierschraube Vis de réglage			1
87	6100928	Kontramøtrik Lock nut Gegenmutter Ecrou contre			1
88	6101752	Slangestuds, vinkel Hose socket, elbow Schlauchstutzen, Winkel Raccord de flexible, coude			1
89	6300050	Omløbsventil, komplet By-pass valve, complete Umlaufventil, komplett Soupape by-pass, compl.			x
91	6301392	Ring Ring ø 160, C3 Ring Anneau			1
94	1602606	Ligeforskrøning Threaded connection Verschraubung Raccord fileté	I I		1
95	6221552	Udluftningsventil, kompl. Venting valve, compl. Entlüftungsventil, kompl. Vis de purgeur, compl.	I I		1
-	5218433	Pump Oil 150, 1 x 1 l.			

Pos. Ref.	Nr. No.	Betegnelse Bezeichnung	Designation Désignation	KSA-1	KSA-2

598 51 75 - Apr. 2002

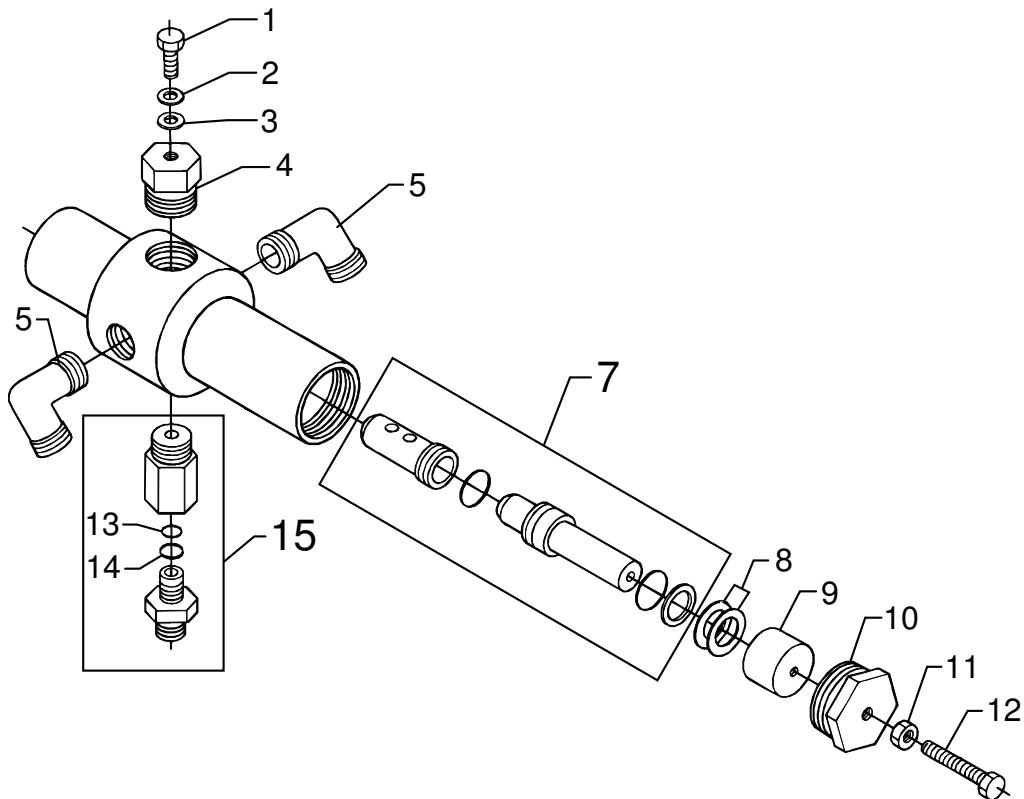
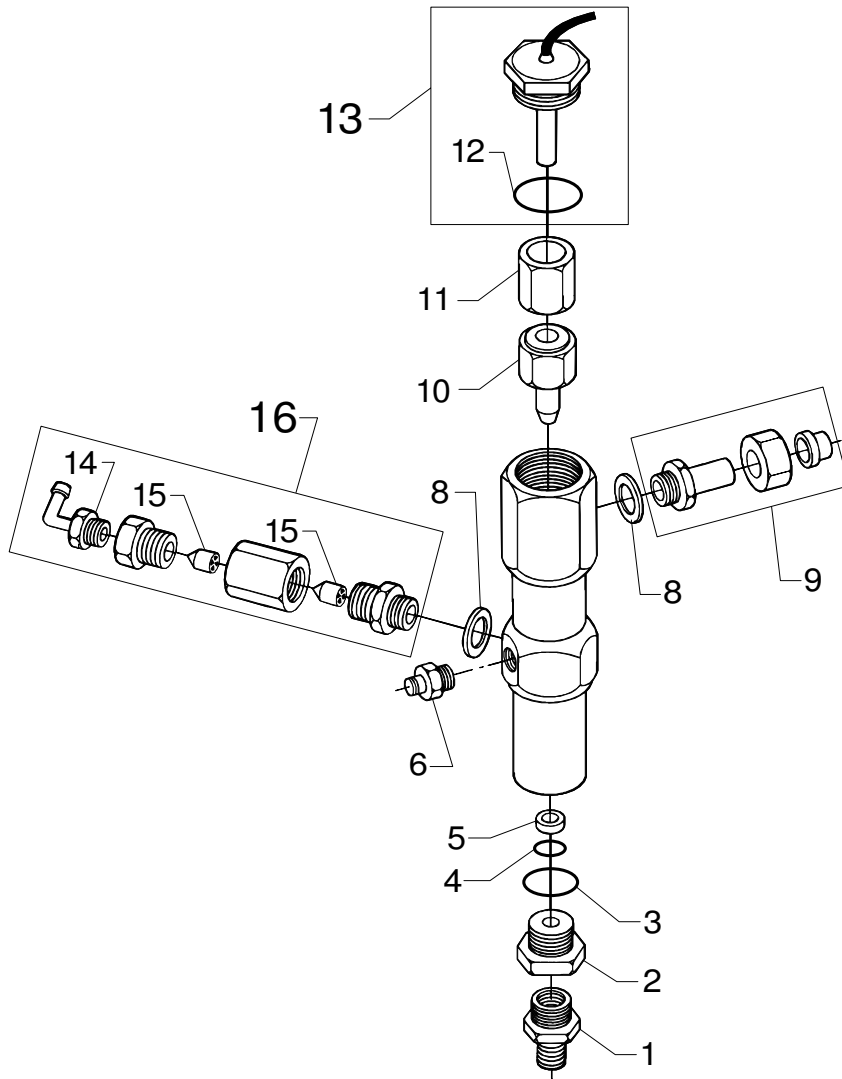

Pos. Ref.	Nr. No.	Betegnels Bezeichnung	Designation Désignation	KSA-1	KSA-2
62	6301126	Strømningskontakt, komplet Flow switch, complete Strömungsschalter, komplett Circulation sélecteur, compl.		x	
62	6301117	Strømningskontakt, komplet Flow switch, complete Strömungsschalter, komplett Circulation sélecteur, compl.			x
1	1603077	Forskruning Threaded connection Verschraubung Raccord fileté		1	1
2	6300438	Omløber Union nut Überwurfmutter Ecrou-raccord		1	1
3	3000262	O-ring O-ring O-Ring Joint torique		1	1
4	3001112	O-ring O-ring O-Ring Joint torique		1	1
5	6350625	Sæde Seat Sitz Siège		1	1
6	6304354	Ligeforskruning Threaded connection Verschraubung Raccord fileté		1	1
8	1803493	Tætningskive Sealing washer Dichtungsscheibe Rondelle d'étanchéité		2	2
9	6200558	Forskruning Threaded connection Verschraubung Raccord fileté		1	1
10	6350463	Kontraventil, kompl. Non-return valve, compl. Rückschlagventil, kompl. Clapet anti-retour, compl.		1	
10	6304323	Kontraventil Non-return valve Rückschlagventil Clapet anti-retour			1
11	6350454	Stempel Piston Kolben Piston		1	1
12	3000825	O-ring O-ring O-Ring Joint torique		1	1
13	6221773	Reedkontakt m. O-ring Reed switch with O-ring Reedschalter mit O-ring Reed sélecteur avec joint torique		1	1
14	1601111	Vinkelslangestuds Hose tail, elbow Schlauchstutzen, Winkel Raccord de tuyau, coude		1	1
15	1119566	Rep.sæt, kontraventil Rep. kit, non-return valve Rep. satz, Rückschlagventil Kit de rép., clapet anti-retour		2	2
16	6301120	Kontraventil, kompl. Non-return valve, compl. Rückschlagventil, kompl. Clapet anti-retour, compl.		1	1
-	1602325	Prop Plug Pfropfen Bouchon	11.09.92 ⇒	1	1

Pos. Ref.	Nr. No.	Betegnels Bezeichnung	Designation Désignation	KSA-1	KSA-2
55	6301119	Overstrømsventil, komplet Overflow valve, complete Überlaufventil, komplett Soupape de passage, compl.			x
1	1800788	Skrue Screw M8x12 Schraube Vis			1
2	1801398	Skive Washer Scheibe Rondelle			1
3	1813898	Skive Washer Scheibe Rondelle			1
4	6304328	Prop Plug 1/2" Pfropfen Bouchon			1
5	6300444	Vinkelforskruning Elbow, threaded connection Winkelverschraubung Coude, raccord fileté			2
7	1119031	Rep.sæt, overstrømsventil Rep.kit, overflow valve Rep.satz, Überlaufventil Kit de rép., soupape de passage			x
8	2600328	Tallerkenfeder Spring washer Tellerfeder Disque ressort			20
9	6300268	Fjederstyr Thrust plate Federfuß Joint d'appui			1
10	6300269	Møtrik Nut Mutter Ecrou			1
11	1803725	Møtrik M8 Nut Mutter Ecrou			1
12	1800622	Skrue M8x35 Screw Schraube Vis			1
13	6301356	Si Strainer Filter Filtre			1
14	3003670	O-ring O-ring O-Ring Joint torique			1
15	6301177	Filter, komplet Filter, compl. Filter, komplett Filtre, compl.			1

Svømmerhus, KSA-1 / Water tank, KSA-1 / Schwimmergehäuse, KSA-1 / Bac à flotteur, KSA-1

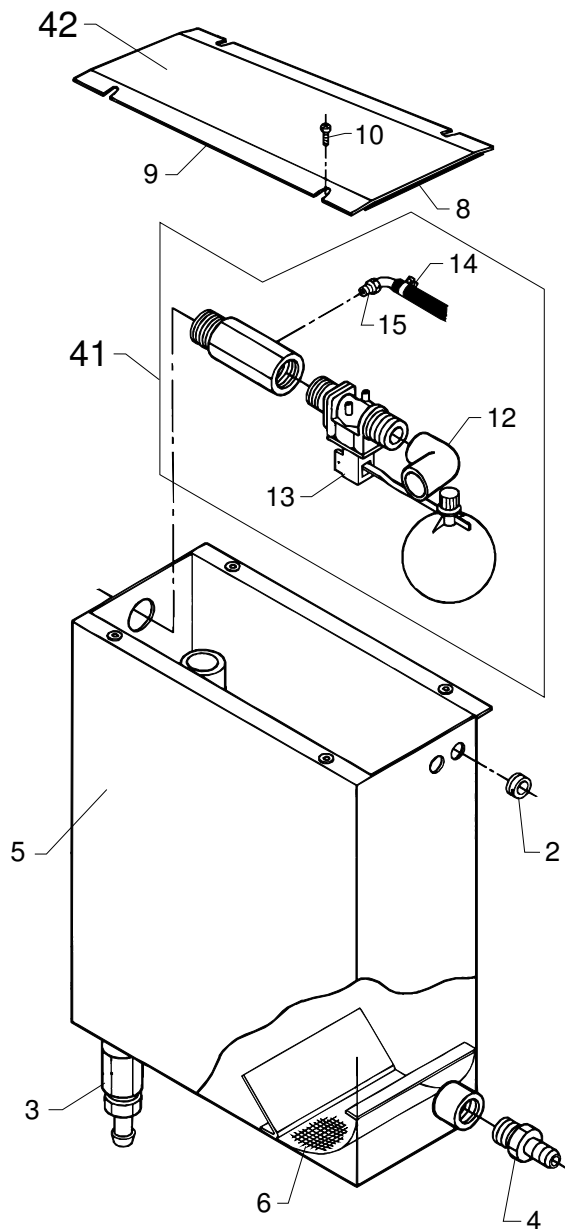

Svømmerhus, KSA-2 / Water tank, KSA-2 / Schwimmergehäuse, KSA-2 / Bac à flotteur, KSA-2

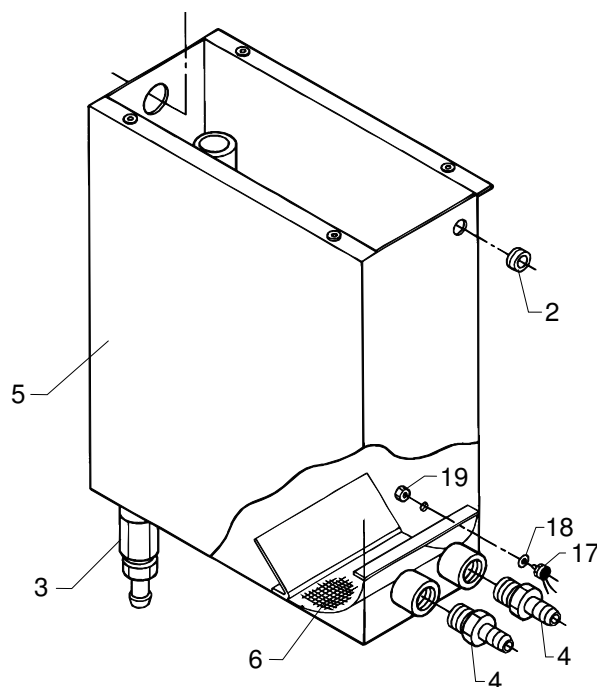

Pos. Ref.	Nr. No.	Betegnels Bezeichnung	Designation Désignation	KSA-1	KSA-2
40	-	Svømmerhus, kompl. Water tank, compl. Schwimmergehäuse, kompl. Bac à flotteur, compl.		x	x
2	3001427	Kabelgennemføring Cable gland Kabeldurchführung Passe fil		2	2
3	6300165	Aftapningshane Drain cock Ablafshahn Robinet de prise		1	1
4	6300262	Slangestuds Hose union Schlauchstutzen Raccord du flexible		1	2
5	6304396	Svømmerhus Water tank Schwimmergehäuse Bac à flotteur			1
5	6304395	Svømmerhus Water tank Schwimmergehäuse Bac à flotteur		1	
6	6304334	Si Strainer Filter Filtre		1	1
17	3821329	Termoafbryder Thermal switch Thermoschalter Interrupteur thermique			1
18	6304356	Tætningskive Sealing washer Dichtungsscheibe Rondelle d'étanchéité			1
19	1802974	Møtrik Nut M4 Mutter Ecrou			1
41	6301116	Svømmerventil, kompl. Float valve, compl. Schwimmerventil, kompl. Clapet anti-retour, compl.		x	
41	6301123	Svømmerventil, kompl. Float valve, compl. Schwimmerventil, kompl. Clapet anti-retour, compl.			x
12	1605971	Vinkel 90° Elbow 90° Winkel 90° Raccord coudé 90°		1	1
13	1119645	Svømmerventil Float valve Schwimmerventil Clapet anti-retour		1	
-	1119644	Svømmerventil Float valve Schwimmerventil Clapet anti-retour			1
14	1807593	Spændebånd, RF Hose clip, SS Schlauchschelle, RF Collier de serrage, INOX		1	1
15	1601111	Slangestuds Hose union Schlauchstutzen Raccord du flexible		1	1

Pos. Ref.	Nr. No.	Betegnels Bezeichnung	Designation Désignation	KSA-1	KSA-2
42	6301115	Låg f. svømmerhus, kompl. Cover, compl. Deckel, kompl. Couvercle, compl.		x	x
8	6304302	Kantliste Edging L=120 mm Kantenleiste Rebord		2	2
9	6304303	Kantliste Edging L=264 mm Kantenleiste Rebord		2	2
10	1804475	Skruer Screw Schraube Vis		4	4

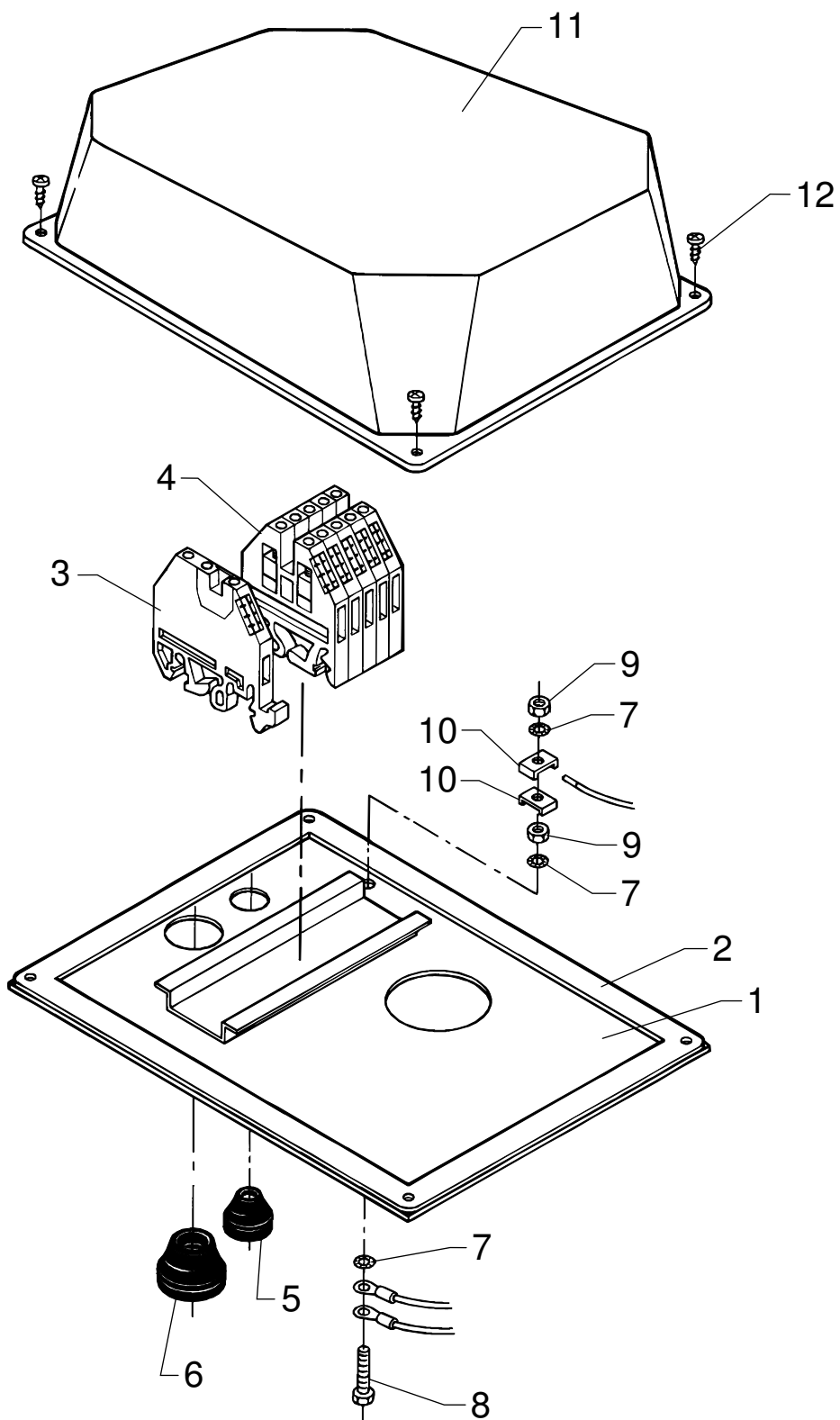

Pos. Ref.	Nr. No.	Betegnelse Bezeichnung	Designation Désignation	KSA-1	KSA-2
115	-	El-monteringsplade, kompl. El. mounting plate, compl. Verbindungsplatte, kompl. Plaque électrique, compl.		x	x
1	6303257	Monteringsplade Mounting plate Montierungsplatte Plaque électrique		1	1
2	6222749	Pakning Gasket Dichtung Joint		1	1
3	3821030	Rækkeklemme Terminal clip Klemme Rangée de bornes		1	1
-	3821030	Rækkeklemme Terminal clip Klemme Rangée de bornes	USA, Offshore, U, CN	3	3
4	3807518	Rækkeklemme Terminal clip Klemme Rangée de bornes		5	5
-	3807518	Rækkeklemme Terminal clip Klemme Rangée de bornes	USA, Offshore, U, CN	2	2
5	3803764	Gummipakdåse Rubber seal TET 5-7C Gummistopfbuchse Presse-étoupe en caouth.		1	1
6	3803780	Gummipakdåse Rubber seal TET 10-14C Gummistopfbuchse Presse-étoupe en caouth.		1	1
7	1802727	Skive Washer Scheibe Rondelle		3	3
8	1802859	Skrue Screw Schraube Vis		1	1
9	1802743	Møtrik Nut M5 Mutter Ecrou		2	2
10	1802735	Klembøjle Clamp Bügel Support		2	2
11	6301394	El-kasse Connection box Elektrogehäuse Boîtier électrique		1	1
12	1802438	Pladeskrue Screw B8x10 Schraube Vis		4	4

Pos. Ref.	Nr. No.	Betegnelse Bezeichnung	Designation Désignation	KSA-1	KSA-2

598 51 75 - Apr. 2002

EI-kasse, KSA-1 / Connection box, KSA-1 / Elektrogehäuse, KSA-1 / Boîtier électrique, KSA-1

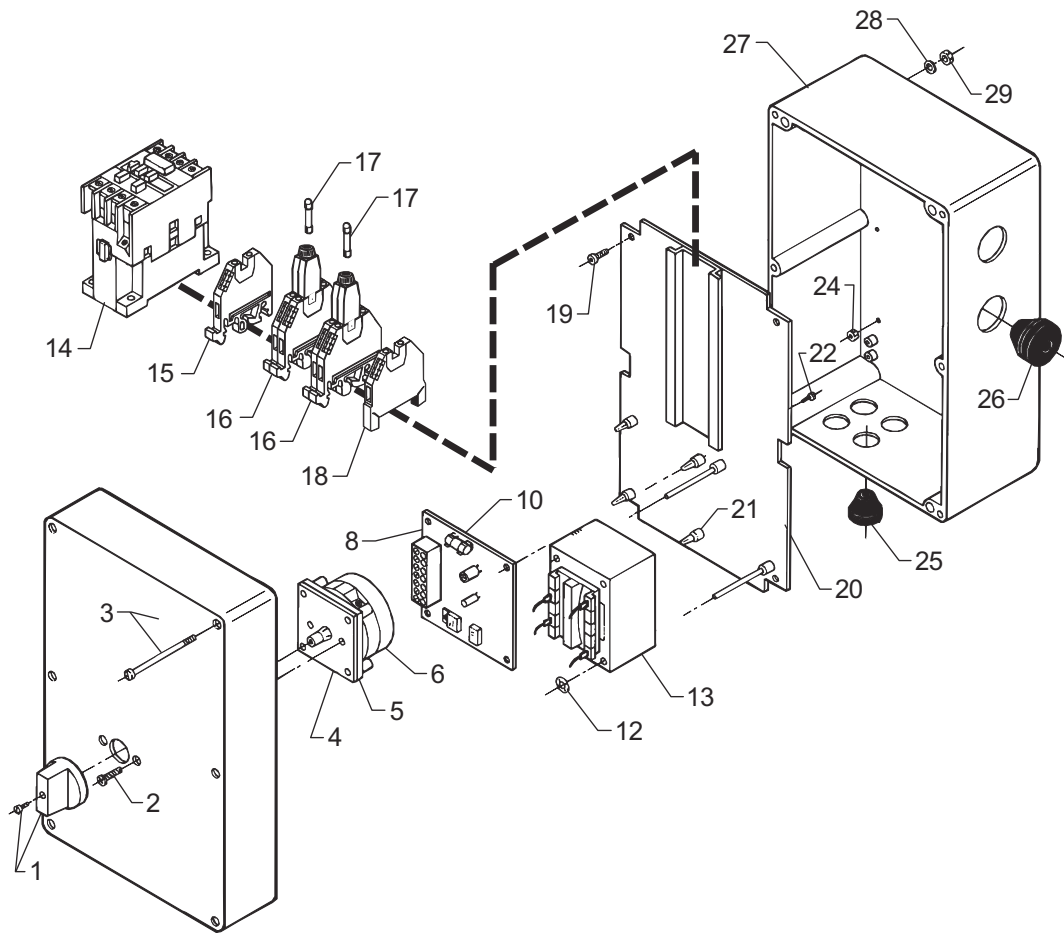

53Sel010

EI-kasse, KSA-2 / Connection box, KSA-2 / Elektrogehäuse, KSA-2 / Boîtier électrique, KSA-2

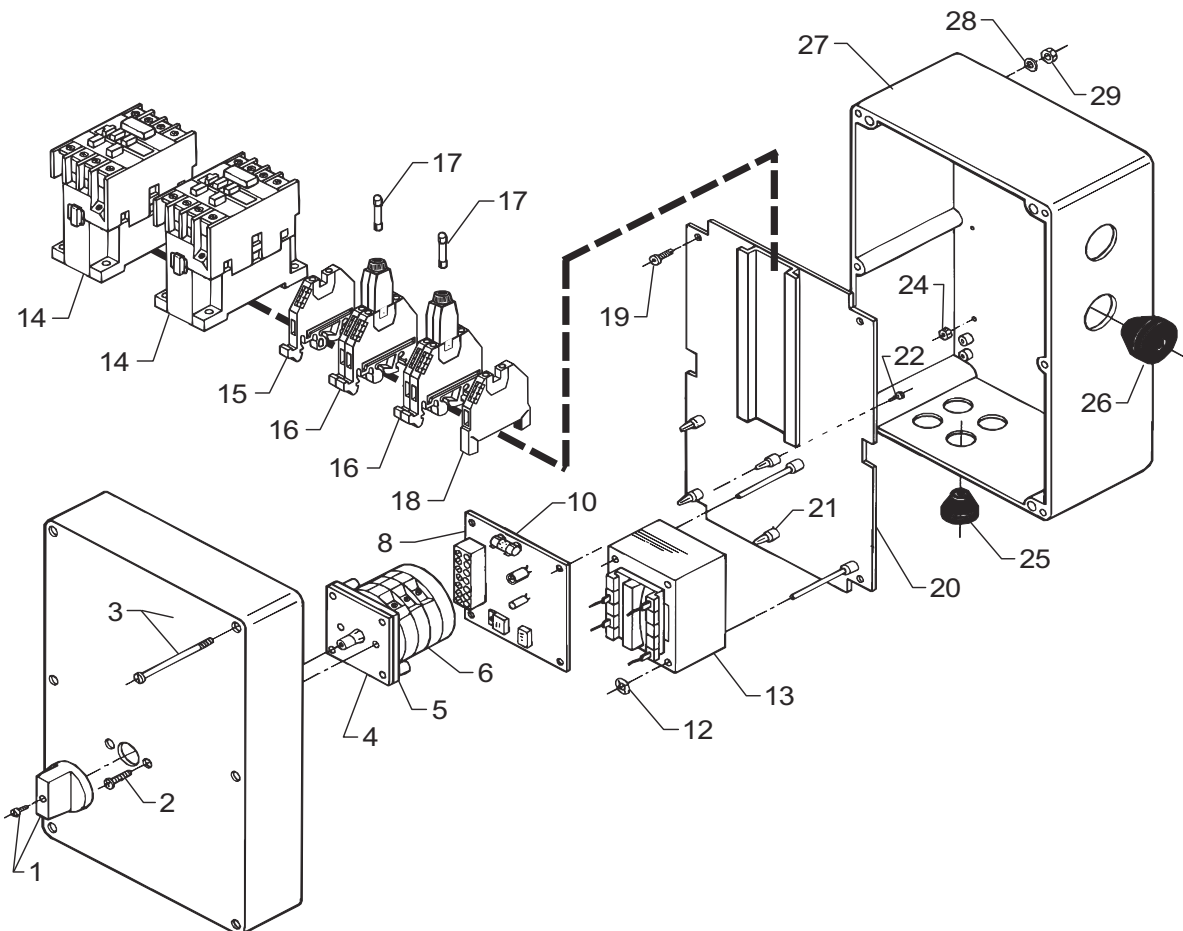

53Sel020

Pos. Ref.	Nr. No.	Betegnels Bezeichnung	Designation Désignation	KSA-1	KSA-2
60	-	El-kasse, kompl. Connection box, compl. Elektrogehäuse, kompl. Boîtier électrique, compl.		x	x
1	3803855	Balkangreb, rød Handle, red Griff, rot Poignée, rouge		1	1
-	3804432	Balkangreb, grå Handle, grey Griff, grau Poignée, gris	f. D	1	1
2	1802685	Skrue Screw Schraube Vis		2	2
3	6303255	Låg Cover Deckel Couvercle		1	1
4	6101009	Pakning Gasket Dichtung Joint		1	1
5	3804580	Topplade m. labyrintring Top plate w. labyrinth ring Oberplatte m. Labyrinthring Plaque en dessus		1	1
6	3821726	Start/stop kontakt Start/stop switch Start/Stop-Schalter Poignée (marché/arrêt)		1	
-	3821182	Drejeafbryder Rotary switch Dreheschalter Interrupteur			1
8	6420012	Automatisk start/stop Automatic start/stop Start/Stop Automatik Marché/arrêt auto.		1	
-	6420014	Automatisk start/stop Automatic start/stop Start/Stop Automatik Marché/arrêt auto.			1
10	3802246	Sikring Fuse Ø5x20, 1,6 AT Sicherung Fusible		1	
10	103821729	Sikring Fuse Ø5x20, 2A T Sicherung Fusible			1
12	1814433	Låseskive Circlip Sicherungsscheibe Rondelle	10.03.95 =>	2	2
-	1805563	Låseskive Circlip Sicherungsscheibe Rondelle	=> 10.03.95	2	2
13	-	Styretransformer Steering transformer Steuerungstransformer Transformateur commande			
-	3821148	24V/220V	USA, N, CN, offshore	1	1
-	3821149	24V/380V		1	1
-	3821150	24V/415V	GB	1	1
-	3821151	24V/440V	USA, offshore, U	1	1
14	3804051	Kontaktor, kompl. max. 16A Contactor, compl. CA3-16-10 24V, 50/60 Hz Schütz, kompl. Contacteur, compl.		1	2
-	3804051	Max. 16A, CA3-16-10 24V, 50/60 Hz		1	2
-	3804168	Max. 23A, CA3-23-10 24V	=> 31.12.99	1	2
-	3821739	23A 24V 50-60Hz	01.01.00 =>	1	2
-	103821815	30A 24V 50-60Hz		1	2
14A	3821748	Hjælpekontakt Auxiliary switch Hilfschalter Bouton auxiliaire			1

Pos. Ref.	Nr. No.	Betegnels Bezeichnung	Designation Désignation	KSA-1	KSA-2
15	3807518	Rækkelemme Terminal screw Anschlußklemme Borne		1	1
16	3808003	Rækkelemme f. sikringshus Terminal screw f. fuse housing Anschlußklemme f. Sicherungsgehäuse Borne p. porte-fusible		2	2
17	3819521	Sikring Fuse Sicherung Fusible		2	2
18	3817483	Rækkelemme, jord Terminal screw, earth Anschlußklemme, Erdung Borne, terre		1	1
19	1800481	Maskinskrue Screw M4x16 Schraube Vis		4	4
20	6303253	El-plade El. mounting plate El. Verbindungsplatte Plaque électrique		1	1
21	4600771	Printstag Tie rod Abstandsstange Tirant		4	4
22	1813823	Pt-skrue Pt-screw Pt-Schraube Vis Pt		4	4
24	1800127	Låsemøtrik Lock nut M4 Gegenmutter Ecroû de blocage		4	4
25	3803764	Gummipakdåse Cable grommet TET 5-7C Dichtungsgehäuse Presse-étoupe en caouth.		4	4
26	3803780	Gummipakdåse Cable grommet TET 10-14C Dichtungsgehäuse Presse-étoupe en caouth.		4	4
27	6303254	Kasse Box Gehäuse Boîtier		1	1
28	1814458	Fiberskive Fibre washer Fiberscheibe Rondelle		8	8
29	1800127	Låsemøtrik Lock nut M4 Mutter Ecroû de blocage		4	4